

**AUTOMOTIVE INDUSTRY STANDARD**

**Provisions concerning the approval of  
Passenger Cars in the event of  
Frontal Collision with focus on  
Restraint Systems**

PRINTED BY  
THE AUTOMOTIVE RESEARCH ASSOCIATION OF INDIA  
P.B. NO. 832, PUNE 411 004

ON BEHALF OF  
AUTOMOTIVE INDUSTRY STANDARDS COMMITTEE

UNDER  
CENTRAL MOTOR VEHICLE RULES – TECHNICAL STANDING COMMITTEE

SET-UP BY  
MINISTRY OF ROAD TRANSPORT and HIGHWAYS  
GOVERNMENT OF INDIA

March 2025

## INTRODUCTION

The Government of India felt the need for a permanent agency to expedite the publication of standards and development of test facilities in parallel when the work on the preparation of the standards is going on, as the development of improved safety critical parts can be undertaken only after the publication of the standard and commissioning of test facilities. To this end, the erstwhile Ministry of Surface Transport (MoST) has constituted a permanent Automotive Industry Standards Committee (AISC) vide order No. RT-11028/11/97-MVL dated September 15, 1997. The standards prepared by AISC will be approved by the permanent CMVR Technical Standing Committee (CTSC). After approval, the Automotive Research Association of India, (ARAI), Pune, being the secretariat of the AIS Committee, has published this standard.

Based on deliberations in the CMVR-TSC and AISC it has been decided to create a suite of standards related to Passive Safety which are founded on dynamic (or crash) testing of passenger cars and utility vehicles. These standards would then form the basis of the notification and implementation of advanced passive safety norms in the latter part of this decade as per the Safety Road Map adopted for India.

This is further advancement in the series of crash related test standards following AIS-096 (Steering protection in head on impact), AIS-098 (Off-set frontal impact) and AIS-099 (Side impact) which were implemented in 2017 through notification SO1139(E) dt. 28 April 2015 issued by MoRTH, Government of India. This is an entirely new standard for Indian automotive field and applicable for M1 category vehicles with GVW less than 3500 kg. Vehicles upgraded to meet this standard would have achieved a higher level of occupant safety by ensuring tolerable design of restraint systems for small female occupants and elderly occupants in full width rigid barrier load-cases.

N1 category vehicles are currently not proposed in the scope of this standard based on following grounds

- M1 class vehicles are currently equipped with restraint systems including airbags and Seat-Belt reminders. Current applicable CMVR provisions for N1 class vehicles do not warrant for such systems
- This standard attempts to achieve improvements into restraint systems by ensuring lesser chest deflection to elderly male and small female occupants.
- N1 class vehicles can be considered for inclusion in scope in future based upon availability of additional data along with cost benefit analysis

While preparing this AIS considerable assistance is derived from following international standard:

UN R 137 (Supp. 2 to 02 Series of Amd.) Uniform Provisions Concerning the Approval of Passenger Cars in the Event of a Frontal Collision with Focus on the Restraint System.

The AISC panel and Automotive Industry Standards Committee responsible for preparation are given in Annex 7 and 8 respectively.

**Provisions concerning the approval of Passenger Cars in the event of  
Frontal Collision with focus on Restraint Systems**

| <b>Para No.</b>          | <b>Contents</b>   | <b>Page No.</b> |
|--------------------------|---|-----------------|
| 0                        | Scope   | 1/53            |
| 1                        | References  | 1/53            |
| 2                        | Definitions   | 2/53            |
| 3                        | Application for Approval  | 6/53            |
| 4                        | Approval  | 7/53            |
| 5                        | Specifications  | 7/53            |
| 6                        | Instructions for users of vehicles equipped with airbags                    | 14/53           |
| 7                        | Criteria for extension of type approvals                                    | 14/53           |
| <b>List of Annexures</b> |   |                 |
| Annex 1                  | Test procedure  | 16/53           |
| Annex 2                  | Determination of performance criteria                                       | 23/53           |
| Annex 3                  | Arrangement and installation of dummies and adjustment of restraint systems | 26/53           |
| Annex 4                  | Test procedure with trolley   | 33/53           |
| Annex 5                  | Technique of measurement in measurement tests: instrumentation              | 36/53           |
| Annex 6                  | Test procedures for vehicles equipped with the electric power train         | 42/53           |
| Annex 7                  | Composition of AISC Panel   | 51/53           |
| Annex 8                  | AISC Committee composition  | 53/53           |

|           |  |   |
|-----------|--|---|
|           | <b>Provisions concerning the approval of Passenger Cars in the event of Frontal Collision with focus on Restraint Systems</b>                      |   |
| <b>0.</b> | <b>SCOPE</b>   |   |
| 0.1       | This Standard applies to vehicles of category M <sub>1</sub> with a maximum permissible mass not exceeding 3500 kg.                                |   |
| 0.2       | This standard shall not apply to multi-stage built vehicles produced in quantities not exceeding 500 vehicles in any period of 12 months duration. |   |
| <b>1.</b> | <b>REFERENCES</b>  |   |
| 1.1       | FMVSS (49CFR) Part 572, Sub part E, August 2004  | Anthropomorphic Test Devices, Hybrid III Test Dummy   |
| 1.2       | AIS-096  | Requirements for Behaviour of Steering Mechanism of a Vehicle in a Head on Collision  |
| 1.3       | AIS-097  | Procedure for Determining the "H" Point and the Torso Angle for 50th Percentile Adult Male in Seating Positions of Motor Vehicles |
| 1.4       | AIS-098  | Requirements for the Protection of the Occupants in the event of an Offset Frontal Collision                                      |
| 1.5       | IS 15139   | Automotive Vehicles – Safety Belt Anchorages – Specification  |
| 1.6       | IS 15140   | Automotive Vehicles – Safety Belt and Restraint Systems – Specification   |
| 1.7       | IS 16694   | Automotive Vehicles – Safety Belts, Restraint Systems and Safety Belt Reminder – Installation Requirements                        |
| 1.8       | AIS-145  | Additional Safety features for Category M and N Vehicles  |
| 1.9       | FMVSS 208  | Drawings 78051 – 292 and 293 for Dummy Clothing   |

|       |  |
|-------|--|
| 2.    | <p><b>DEFINITIONS</b></p> <p>For the purpose of this Standard:</p>   |
| 2.1   | <p><b>"Protective system"</b> means interior fittings and devices intended to restrain the occupants and contribute towards ensuring compliance with the requirements set out in paragraph 5 below.</p>  |
| 2.2   | <p><b>"Type of protective system"</b> means a category of protective devices which do not differ in such essential respects as their:</p> <p>Technology;<br/>Geometry;<br/>Constituent materials.</p>  |
| 2.3   | <p><b>"Vehicle width"</b> means the distance between two planes parallel to the longitudinal median plane (of the vehicle) and touching the vehicle on either side of the said plane but excluding the external devices for indirect vision, side marker lamps, tyre pressure indicators, direction indicator lamps, position lamps, flexible mud-guards and the deflected part of the tyre side-walls immediately above the point of contact with the ground.</p> |
| 2.4   | <p><b>"Vehicle type"</b> means a category of power-driven vehicles which do not differ in such essential respects in so far as they have a negative effect on the results of the impact test prescribed in this Standard such as:</p>  |
| 2.4.1 | <p>The length and width of the vehicle,</p>  |
| 2.4.2 | <p>The structure, dimensions, lines and materials of the part of the vehicle forward of the transverse plane through the "R" point of the driver's seat,</p>   |
| 2.4.3 | <p>The lines and inside dimensions of the passenger compartment and the type of protective system,</p>   |
| 2.4.4 | <p>The siting (front, rear or centre) and the orientation (transversal or longitudinal) of the engine,</p>   |
| 2.4.5 | <p>The unladen mass,</p>   |
| 2.4.6 | <p>The optional arrangements or fittings provided by the manufacturer,</p>   |
| 2.4.7 | <p>The locations of the REESS.</p>   |

|       |   |
|-------|---|
| 2.5   | <b>Passenger compartment</b>  |
| 2.5.1 | <b>"Passenger compartment with regard to occupant protection"</b> means the space for occupant accommodation, bounded by the roof, floor, side walls, doors, outside glazing and front bulkhead and the plane of the rear compartment bulkhead or the plane of the rear-seat back support;  |
| 2.5.2 | <b>"Passenger compartment for electric safety assessment"</b> means the space for occupant accommodation, bounded by the roof, floor, side walls, doors, outside glazing, front bulkhead and rear bulkhead, or rear gate, as well as by the electrical protection barriers and enclosures provided for protecting the occupants from direct contact with high voltage live parts.   |
| 2.6   | <b>"R point"</b> means a reference point defined for each seat by the manufacturer in relation to the vehicle's structure, indicated in accordance to AIS-097, as amended from time to time.  |
| 2.7   | <b>"H point"</b> means a reference point determined for each seat by the testing service responsible for approval, in accordance with the procedure described in AIS-097, as amended from time to time.   |
| 2.8   | <b>"Unladen kerb mass"</b> means the mass of the vehicle in running order, unoccupied and unladen but complete with fuel, coolant, lubricant, tools and a spare wheel (if these are provided as standard equipment by the vehicle manufacturer).  |
| 2.9   | <b>"Airbag"</b> means a device installed to supplement safety belts and restraint systems in power-driven vehicles, i.e. systems which, in the event of a severe impact affecting the vehicle, automatically deploy a flexible structure intended to limit, by compression of the gas contained within it, the gravity of the contacts of one or more parts of the body of an occupant of the vehicle with the interior of the passenger compartment. |
| 2.10  | <b>"Passenger airbag"</b> means an airbag assembly intended to protect occupant(s) in seats other than the driver's in the event of a frontal collision.  |
| 2.11  | <b>"High voltage"</b> means the classification of an electric component or circuit, if its working voltage is $> 60 \text{ V}$ and $\leq 1,500 \text{ V}$ direct current (DC) or $> 30 \text{ V}$ and $\leq 1,000 \text{ V}$ alternating current (AC) root – mean – square (rms).   |

|      |   |
|------|---|
| 2.12 | <p><b>"Rechargeable Electrical Energy Storage System (REESS)"</b> means the rechargeable electrical energy storage system which provides electric energy for propulsion.</p> <p>A battery whose primary use is to supply power for starting the engine and/or lighting and/or other vehicle auxiliaries' systems is not considered as a REESS.</p> <p>The REESS may include the necessary systems for physical support, thermal management, electronic controls and casing.</p> |
| 2.13 | <p><b>"Electrical protection barrier"</b> means the part providing protection against any direct contact to the high voltage live parts.</p>  |
| 2.14 | <p><b>"Electric power train"</b> means the electrical circuit which includes the traction motor(s), and may also include the REESS, the electrical energy conversion system, the electronic converters, the associated wiring harness and connectors, and the coupling system for charging the REESS.</p>   |
| 2.15 | <p><b>"Live parts"</b> means conductive part(s) intended to be electrically energized under normal operating conditions.</p>  |
| 2.16 | <p><b>"Exposed conductive part"</b> means the conductive part which can be touched under the provisions of the protection Degree IPXXB which is not normally energized, but which can become electrically energized under isolation failure conditions. This includes parts under a cover that can be removed without using tools.</p>  |
| 2.17 | <p><b>"Direct contact"</b> means the contact of persons with high voltage live parts.</p>   |
| 2.18 | <p><b>"Indirect contact"</b> means the contact of persons with exposed conductive parts.</p>  |
| 2.19 | <p><b>"Protection Degree IPXXB"</b> means protection from contact with high voltage live parts provided by either an electrical protection barrier or an enclosure and tested using a Jointed Test Finger (IPXXB) as described in paragraph 4 of Annex 6.</p>   |
| 2.20 | <p><b>"Working voltage"</b> means the highest value of an electrical circuit voltage root-mean-square (rms), specified by the manufacturer, which may occur between any conductive parts in open circuit conditions or under normal operating conditions. If the electrical circuit is divided by galvanic isolation, the working voltage is defined for each divided circuit, respectively.</p>  |
| 2.21 | <p><b>"Coupling system for charging the Rechargeable Electrical Energy Storage System (REESS)"</b> means the electrical circuit used for charging the REESS from an external electrical power supply including the vehicle inlet.</p>   |

|      |  |
|------|--|
| 2.22 | <b>"Electrical chassis"</b> means a set made of conductive parts electrically linked together, whose electrical potential is taken as reference.   |
| 2.23 | <b>"Electrical circuit"</b> means an assembly of connected live parts which is designed to be electrically energized in normal operation.  |
| 2.24 | <b>"Electrical energy conversion system"</b> means a system (e.g. fuel cell) that generates and provides electrical energy for electrical propulsion.  |
| 2.25 | <b>"Electronic converter"</b> means a device capable of controlling and/or converting electrical power for electrical propulsion.  |
| 2.26 | <b>"Enclosure"</b> means the part enclosing the internal units and providing protection against any direct contact.  |
| 2.27 | <b>"High voltage bus"</b> means the electrical circuit, including the coupling system for charging the REESS that operates on a high voltage. Where electric circuits, that are galvanically connected to each other and fulfil the specific voltage condition, only the components or parts of the electric circuit that operate on high voltage are classified as a high voltage bus |
| 2.28 | <b>"Solid insulator"</b> means the insulating coating of wiring harnesses, provided in order to cover and prevent the high voltage live parts from any direct contact.   |
| 2.29 | <b>"Automatic disconnect"</b> means a device that when triggered, galvanically separates the electrical energy sources from the rest of the high voltage circuit of the electric power train.  |
| 2.30 | <b>"Open type traction battery"</b> means a type of battery requiring filling with liquid and generating hydrogen gas that is released to the atmosphere.  |
| 2.31 | <b>"Automatically activated door locking system"</b> means a system that locks the doors automatically at a pre-set speed or under any other condition as defined by the manufacturer.   |
| 2.32 | <b>"Displacement system"</b> means a device by which the seat or one of its parts can be displaced and/or rotated, without a fixed intermediate position, to permit easy access of occupants to and from the space behind the seat concerned.  |
| 2.33 | <b>"Aqueous electrolyte"</b> means an electrolyte based on water solvent for the compounds (e.g. acids, bases) providing conducting ions after its dissociation.   |
| 2.34 | <b>"Electrolyte leakage"</b> means the escape of electrolyte from the REESS in the form of liquid.   |

|           |   |
|-----------|---|
| 2.35      | <b>"Non-aqueous electrolyte"</b> means an electrolyte not based on water as the solvent.  |
| 2.36      | <b>"Normal operating conditions"</b> include operating modes and conditions that can reasonably be encountered during typical operation of the vehicle including driving at legally posted speeds, parking and standing in traffic, as well as, charging using chargers that are compatible with the specific charging ports installed on the vehicle. It does not include, conditions where the vehicle is damaged, either by a crash, road debris or vandalization, subjected to fire or water submersion, or in a state where service and or maintenance is needed or being performed. |
| 2.37      | <b>"Specific voltage condition"</b> means the condition that the maximum voltage of a galvanically connected electric circuit between a DC live part and any other live part (DC or AC) is $\leq 30\text{VAC}$ (rms) and $\leq 60\text{VDC}$ .  |
|           | Note 1: When a DC live part of such an electric circuit is connected to electrical chassis and the specific voltage condition applies, the maximum voltage between any live part and the electrical chassis is $\leq 30\text{VAC}$ (rms) and $\leq 60\text{VDC}$ .<br><br>Note 2: For pulsating DC voltages (alternating voltages without change of polarity) the DC threshold shall be applied.  |
| 2.38      | <b>"State of Charge (SOC)"</b> means the available electrical charge in a REESS expressed as a percentage of its rated capacity.  |
| 2.39      | <b>"Fire"</b> means the emission of flames from the vehicle. Sparks and arcing shall not be considered as flames.   |
| 2.40      | <b>"Explosion"</b> means the sudden release of energy sufficient to cause pressure waves and/or projectiles that may cause structural and/or physical damage to the surrounding of the vehicle.   |
| <b>3.</b> | <b>APPLICATION FOR APPROVAL</b>   |
| 3.1       | The application for approval of a vehicle type with regard to the protection of the occupants of the front seats in the event of a frontal collision shall be submitted by the vehicle manufacturer or by their duly accredited representative.   |
| 3.2       | It shall be accompanied by the undermentioned documents with following particulars:   |
| 3.2.1     | A detailed description of the vehicle type with respect to its structure, dimensions, lines and constituent materials;  |
| 3.2.2     | Photographs, and/or diagrams and drawings of the vehicle showing the vehicle type in front, side and rear elevation and design details of the forward part of the structure;  |

|           |  |
|-----------|--|
| 3.2.3     | Particulars of the vehicle's unladen kerb mass;  |
| 3.2.4     | The lines and inside dimensions of the passenger compartment;  |
| 3.2.5     | A description of the interior fittings and protective systems installed in the vehicle;  |
| 3.2.6     | A general description of the electrical power source type, location and the electric power train (e.g. hybrid, electric).  |
| 3.3       | The applicant for approval shall be entitled to present any data and results of tests carried out which make it possible to establish that compliance with the requirements can be achieved with a sufficient degree of confidence.  |
| 3.4       | A vehicle which is representative of the type to be approved shall be submitted to the Test Agency responsible for conducting the approval tests.  |
| 3.4.1     | A vehicle not comprising all the components proper to the type may be accepted for test provided that it can be shown that the absence of the components has no detrimental effect on the results of the test in so far as the requirements are concerned.                 |
| 3.4.2     | It shall be the responsibility of the applicant for approval to show that the application of paragraph 3.4.1. above is compatible with compliance with the requirements.   |
| <b>4.</b> | <b>APPROVAL</b>  |
| 4.1       | If the vehicle type submitted for approval pursuant to this Standard meets the requirements, approval of that vehicle type shall be granted.   |
| 4.1.1     | The Test Agency appointed shall check whether the required conditions have been satisfied.   |
| 4.1.2     | In case of doubt, account shall be taken, when verifying the conformity of the vehicle to the requirements, of any data or test results provided by the manufacturer which can be taken into consideration in validating the approval test carried out by the Test Agency. |
| 4.2       | Notice of approval or of refusal of approval of a vehicle type pursuant to this Standard shall be communicated by the Test Agency to the applicant.  |
| <b>5.</b> | <b>SPECIFICATIONS</b>  |
| 5.1       | General specifications   |
| 5.1.1     | The "H" point for each seat shall be determined in accordance to the procedure described in AIS-097, as amended from time to time.   |

|           |   |
|-----------|---|
| 5.1.2     | When the protective system for the front seating positions includes belts, the belt components shall meet the requirements of IS-15140 and IS-16694 and AIS-145, as amended from time to time.  |
| 5.1.3     | Seating positions where a dummy is installed and the protective system includes belts, shall be provided with anchorage points conforming to IS-15139, as amended from time to time.  |
| 5.2       | <p>Specifications for the restraint system test (Full Width Rigid Barrier test).</p> <p>The vehicle shall be tested and approved in accordance with the method described in Annex 1.</p> <p>The vehicle which, in agreement with the Test Agency, is considered as having the worst case effect on the result of the injury criteria specified in paragraph 5.2.1. shall be selected for this test.</p> <p>The test of the vehicle carried out in accordance with the method described in Annex 1, shall be considered satisfactory if all the conditions set out in paragraphs 5.2.1. to 5.2.6. below are all satisfied at the same time.</p> <p>Additionally, vehicles equipped with electric power train shall meet the requirements of paragraph 5.2.8.</p> <p>This can be met by a separate impact test at the request of the manufacturer and after validation by the Test Agency, provided that the electrical components do not influence the occupant protection performance of the vehicle type as defined in paragraphs 5.2.1. to 5.2.5. In case of this condition the requirements of paragraph 5.2.8. shall be checked in accordance with the methods set out in Annex 1 to this Standard, except paragraphs 2., 5. and 6. of Annex 1.</p> <p>A dummy corresponding to the specifications for Hybrid III fiftieth percentile (see footnote 1 of Annex 1) fitted with a 45° ankle angle and meeting the specifications for its adjustment shall be installed in driver’s seat. A dummy corresponding to the specifications for Hybrid III fifth percentile (see footnote 1 of Annex 1) fitted with a 45° ankle angle and meeting the specifications for its adjustment shall be installed in the front outboard passenger’s seat.</p> |
| 5.2.1     | The performance criteria described in Annex 2 and recorded in accordance with Annex 5, on the dummies in the front outboard seats shall meet the following conditions:  |
| 5.2.1.1   | Hybrid III fiftieth percentile adult male performance requirements:   |
| 5.2.1.1.1 | The Head Performance Criterion (HPC) shall not exceed 1,000 and the resultant head acceleration shall not exceed 80 g for more than 3 ms. The latter shall be calculated cumulatively, excluding rebound movement of the head;  |

|           |  |
|-----------|--|
| 5.2.1.1.2 | The injury criteria for neck shall not exceed the following values:  |
|           | (a) The axial tensile neck force shall not exceed 3.3 kN;  |
|           | (b) The fore/aft shear forces at the head/neck interface shall not exceed 3.1 kN;  |
|           | (c) The neck bending moment about the y axis shall not exceed 57 Nm in extension;  |
| 5.2.1.1.3 | The Thorax Compression Criterion (ThCC) shall not exceed 42 mm.  |
| 5.2.1.1.4 | The Viscous Criterion ( $V * C$ ) for the thorax shall not exceed 1.0 m/s;   |
| 5.2.1.1.5 | The Femur Force Criterion (FFC) shall not exceed 9.07 kN.  |
| 5.2.1.2   | Hybrid III fifth percentile adult female performance requirements:   |
| 5.2.1.2.1 | The Head Performance Criterion (HPC) shall not exceed 1,000 and the resultant head acceleration shall not exceed 80 g for more than 3 ms. The latter shall be calculated cumulatively, excluding rebound movement of the head;   |
| 5.2.1.2.2 | The injury criteria for neck shall not exceed the following values:  |
|           | (a) The axial tensile neck force shall not exceed 2.9 kN;  |
|           | (b) The fore/aft shear forces at the head/neck interface shall not exceed 2.7 kN;  |
|           | (c) The neck bending moment about the y axis shall not exceed 57 Nm in extension.  |
| 5.2.1.2.3 | The Thorax Compression Criterion (ThCC) shall not exceed 34 <sup>(1)</sup> mm.   |
|           | <sup>(1)</sup> This threshold limit is derived from the injury criteria of a 65-year old fifth percentile female. This criterion should be limited to the front outboard passenger position under the load case and the test condition of this Regulation. Its usage should only be extended following further consideration and review. |
| 5.2.1.2.4 | The Viscous Criterion ( $V * C$ ) for the thorax shall not exceed 1.0 m/s;   |
| 5.2.1.2.5 | The Femur Force Criterion (FFC) shall not exceed 7 kN.   |
| 5.2.2     | Steering wheel displacement  |
| 5.2.2.1   | After the test the residual steering wheel displacement, when measured at the centre of the steering wheel hub, shall not exceed 80 mm in the upwards vertical direction and 100 mm in the rearward horizontal direction.  |
| 5.2.2.2   | Vehicles meeting the steering wheel displacement requirements of either AIS-096 or AIS-098, as amended from time to time, are deemed to comply with paragraph 5.2.2.1 specified above.   |

|           |   |
|-----------|---|
| 5.2.3     | During the test no door shall open.   |
| 5.2.3.1   | In the case of automatically activated door locking systems which are installed optionally and/or which can be de-activated by the driver, this requirement shall be verified by using one of the following two test procedures, at the choice of the manufacturer:   |
| 5.2.3.1.1 | If testing in accordance with Annex 1, paragraph 1.4.3.5.2.1., the manufacturer shall in addition demonstrate to the satisfaction of the Test Agency (e.g. manufacturer's in-house data) that, in the absence of the system or when the system is de-activated, no door will open in case of the impact.  |
| 5.2.3.1.2 | The test is conducted in accordance with Annex 1, paragraph 1.4.3.5.2.2.  |
| 5.2.4     | After the impact, the side doors shall be unlocked.   |
| 5.2.4.1   | In the case of vehicles equipped with an automatically activated door locking system, the doors shall be locked before the moment of impact and be unlocked after the impact.   |
| 5.2.4.2   | In the case of vehicles equipped with automatically activated door locking systems which are installed optionally and/or which can be de-activated by the driver, this requirement shall be verified by using one of the following two test procedures, at the choice of the manufacturer:  |
| 5.2.4.2.1 | If testing in accordance with Annex 1, paragraph 1.4.3.5.2.1., the manufacturer shall in addition demonstrate to the satisfaction of the Test Agency (e.g. manufacturer's in-house data) that, in the absence of the system or when the system is de-activated, no locking of the side doors shall occur during the impact.   |
| 5.2.4.2.2 | The test is conducted in accordance with Annex 1, paragraph 1.4.3.5.2.2.  |
| 5.2.5     | After the impact, it shall be possible, without the use of tools except for those necessary to support the weight of the dummy:   |
| 5.2.5.1   | To open at least one door, per row of seats, where there is no such door, it shall be possible to allow the evacuation of all the occupants by activating the displacement system of the seats, if necessary. This is not applicable to convertibles where the top can be easily opened to allow the evacuation of the occupants;<br><br>This shall be assessed for all configurations or worst-case configuration for the number of doors on each side of the vehicle and for both left-hand drive and right-hand drive vehicles, when applicable. |

|           |   |
|-----------|---|
| 5.2.5.2   | To release the dummies from their restraint system which, locked, shall be capable of being released by a maximum force of 60 N on the centre of the release control;   |
| 5.2.5.3   | To remove the dummies from the vehicle without adjustment of the seats.   |
| 5.2.6     | In the case of a vehicle propelled by liquid fuel, no more than slight leakage of liquid from the fuel feed installation shall occur on collision.  |
| 5.2.7     | If there is continuous leakage of liquid from the fuel-feed installation after the collision, the rate of leakage shall not exceed 30 g/min; if the liquid from the fuel-feed system mixes with liquids from the other systems and the various liquids cannot easily be separated and identified, all the liquids collected shall be taken into account in evaluating the continuous leakage.   |
| 5.2.8     | Following the test conducted in accordance with the procedure defined in Annex 1, the electric power train operating on high voltage, and the high voltage components and systems, which are galvanically connected to the high voltage bus of the electric power train, shall meet the following requirements:   |
| 5.2.8.1   | <p>Protection against electrical shock</p> <p>After the impact the high voltage buses shall meet at least one of the four criteria specified in paragraph 5.2.8.1.1. through paragraph 5.2.8.1.4.2. below.</p> <p>If the vehicle has an automatic disconnect function, or device(s) that conductively divide the electric power train circuit during driving condition, at least one of the following criteria shall apply to the disconnected circuit or to each divided circuit individually after the disconnect function is activated.</p> <p>However, criteria defined in 5.2.8.1.4. below shall not apply if more than a single potential of a part of the high voltage bus is not protected under the conditions of protection degree IPXXB.</p> <p>In the case that the crash test is performed under the condition that part(s) of the high voltage system are not energized, and with the exception of any coupling system for charging the REESS which is not energized during driving condition, the protection against electrical shock shall be proved by either paragraph 5.2.8.1.3. or paragraph 5.2.8.1.4. below for the relevant part(s).</p> |
| 5.2.8.1.1 | <p>Absence of high voltage</p> <p>The voltages <math>U_b</math>, <math>U_1</math> and <math>U_2</math> of the high voltage buses shall be equal or less than 30 VAC or 60 VDC within 60 s after the impact when measured in accordance with paragraph 2 of Annex 6.</p>   |

|             |  |
|-------------|--|
| 5.2.8.1.2   | <p>Low electrical energy</p> <p>The Total Energy (TE) on the high voltage buses shall be less than 0.2 J when measured according to the test procedure as specified in paragraph 3. of Annex 6 with the formula (a).</p> <p>Alternatively, the total energy (TE) may be calculated by the measured voltage <math>U_b</math> of the high voltage bus and the capacitance of the X-capacitors (<math>C_x</math>) specified by the manufacturer according to formula (b) of paragraph 3 of Annex 6.</p> <p>The energy stored in the Y-capacitors (<math>TE_{y1}</math>, <math>TE_{y2}</math>) shall also be less than 0.2 J. This shall be calculated by measuring the voltages <math>U1</math> and <math>U2</math> of the high voltage buses and the electrical chassis, and the capacitance of the Y-capacitors specified by the manufacturer according to formula (c) of paragraph 3 of Annex 6.</p>   |
| 5.2.8.1.3   | <p>Physical protection</p> <p>For protection against direct contact with high voltage live parts, the protection Degree IPXXB shall be provided.</p> <p>The assessment shall be conducted in accordance with Paragraph 4 of Annex 6.</p> <p>In addition, for protection against electrical shock which could arise from indirect contact, the resistance between all exposed conductive parts of electrical protection barriers/enclosures and the electrical chassis shall be lower than <math>0.1 \Omega</math> and the resistance between any two simultaneously reachable exposed conductive parts of electrical protection barriers/enclosures that are less than 2.5 m from each other shall be less than <math>0.2 \Omega</math> when there is current flow of at least 0.2 A. This resistance may be calculated using the separately measured resistances of the relevant parts of electric path.</p> <p>These requirements are satisfied if the galvanic connection has been made by welding. In case of doubt or the connection is established by mean other than welding, measurements shall be made by using one of the test procedures described in Paragraph 4.1 of Annex 6.</p> |
| 5.2.8.1.4   | <p>Isolation resistance</p> <p>The criteria specified in paragraphs 5.2.8.1.4.1. and 5.2.8.1.4.2. below shall be met. The measurement shall be conducted in accordance with paragraph 5. of Annex 6.</p>   |
| 5.2.8.1.4.1 | <p>Electric power train consisting of separate DC- or AC-buses</p> <p>If the AC high voltage buses and the DC high voltage buses are galvanically isolated from each other, isolation resistance between the high voltage bus and the electrical chassis (<math>R_i</math>, as defined in paragraph 5. of Annex 6) shall have a minimum value of <math>100 \Omega/V</math> of the working</p>  |

|             |   |
|-------------|---|
|             | voltage for DC buses, and a minimum value of 500 $\Omega/V$ of the working voltage for AC buses.  |
| 5.2.8.1.4.2 | <p>Electric power train consisting of combined DC- and AC- buses</p> <p>If the AC high voltage buses and the DC high voltage buses are conductively connected, they shall meet one of the following requirements:</p> <p>(a) isolation resistance between the high voltage bus and the electric chassis shall have a minimum value of 500 <math>\Omega/V</math> of the working voltage;</p> <p>(b) isolation resistance between the high voltage bus and the electrical chassis shall have a minimum value of 100 <math>\Omega/V</math> of the working voltage and the AC bus meets the physical protection as described in Paragraph 5.2.8.1.3;</p> <p>(c) Isolation resistance between the high voltage bus and the electrical chassis shall have a minimum value of 100 <math>\Omega/V</math> of the working voltage and the AC bus meets the absence of high voltage as described in Paragraph 5.2.8.1.1.</p> |
| 5.2.8.2     | Electrolyte Leakage   |
| 5.2.8.2.1   | <p>In Case of Aqueous Electrolyte REESS</p> <p>For a period, from the impact until 60 min after the impact, there shall be no electrolyte leakage from the REESS into the passenger compartment and no more than 7% by volume of the REESS electrolyte with a maximum of 5.0L leaked from the REESS to the outside of the passenger compartment. The leaked amount of electrolyte can be measured by usual techniques of determination of liquid volumes after its collection. For containers containing Stoddard, coloured coolant and electrolyte, the fluids shall be allowed to separate by specific gravity then measured.</p>   |
| 5.2.8.2.2   | <p>In Case of Non-Aqueous Electrolyte REESS</p> <p>For a period from the impact until 60 min after the impact, there shall be no liquid electrolyte leakage from the REESS into the passenger compartment, luggage compartment and no liquid electrolyte leakage to outside the vehicle. This requirement shall be verified by visual inspection without disassembling any part of the vehicle.</p>   |
| 5.2.8.3     | <p>REESS retention</p> <p>REESS shall remain attached to the vehicle by at least one component anchorage, bracket, or any structure that transfers loads from REESS to the vehicle structure, and REESS located outside the passenger compartment shall not enter the passenger compartment.</p>  |

|           |  |
|-----------|--|
| 5.2.8.4   | REESS Fire Hazards<br><br>For a period from the impact until 60 min after the impact, there shall be no evidence of fire or explosion from the REESS.  |
| <b>6.</b> | <b>INSTRUCTIONS FOR USERS OF VEHICLES EQUIPPED WITH AIRBAGS</b>  |
| 6.1       | For a vehicle fitted with airbag assemblies intended to protect the driver and occupants other than the driver, compliance with Paragraphs 6.2 of AIS-098, as amended from time, to time shall be demonstrated.  |
| <b>7.</b> | <b>CRITERIA FOR EXTENSION OF TYPE APPROVALS</b>  |
| 7.1       | While examining any modification affecting the structure, number of front seats, the interior trims or fitting, or the position of the vehicle controls; or of mechanical parts which might affect the energy absorbing capability of the front of the vehicle, the testing agency may : |
| 7.1.1     | Consider that the modifications made are unlikely to have an appreciable adverse effect and that in any case the vehicle still complies with the requirements. For example, the following may be treated as modifications unlikely to have appreciable adverse effects :                 |
| 7.1.1.1   | Any change in the engine compartment layout resulting in increased gaps between parts ahead of the firewall.   |
| 7.1.1.2   | Decrease in the unladen kerb mass of the vehicle as defined in paragraph 2.8.  |
| 7.1.1.3   | Reduction in the fuel tank capacity.   |
| 7.1.1.4   | Increase in the number of propeller shaft components   |
| 7.1.1.5   | Decrease in strength of the steering wheel when subjected to the head impact test as per AIS-096, as amended from time to time.  |
| 7.1.1.6   | Decrease in the road wheel disc diameter without change in the material specifications.  |
| 7.1.1.7   | Addition of a rear sunroof to a front sunroof if there is no change in the size, shape and structure of the approved front sunroof,  |
| 7.1.1.8   | Change in the vehicle drivetrain execution from 4X4 to 4X2. or   |
| 7.1.2     | Require to carry out further tests among those described below according to the nature of the modifications –  |
| 7.1.2.1   | Any modification of the vehicle affecting the general form of the structure of the vehicle (including body type like hatchback /notchback/station wagon and type of drive like RHD/LHD) and/or any   |

|           |   |
|-----------|---|
|           | increase in mass greater than 8% which, in the judgment of the testing agency, would have a marked adverse influence on the results of the tests necessitates a repetition of the test as described in Annex 1.   |
| 7.1.2.2   | If the modifications concern only interior fittings, and if the increase in the unladen kerb mass of the vehicle, defined in paragraph 2.10, is not more than 8% and if the number of front seats initially provided in the vehicle remains the same, the following will need to be carried out, if it has a marked adverse influence on the results on the tests, in the judgment of the testing agency: |
| 7.1.2.2.1 | a partial test as defined by the testing agency in relation to the modifications made,  |
| 7.1.2.2.2 | a simplified test, on type approved and proposed configuration, as provided for in Annex 4.   |
| 7.2       | The following will require a repetition of test as described in Annex 1 or Annex 4 at the choice of the manufacturer. While establishing the compliance with test as per Annex 4, it is necessary to compare the results between type approved configuration and proposed configuration by subjecting both these configurations for the test as per Annex 4.  |
| 7.2.1     | Any change in the seat structure, which will result in reduced forward excursion of the test dummy during the test.   |
| 7.2.2     | Addition of safety equipment such as airbags or seat belts with pretensioner and load limiters.   |
| 7.2.3     | Any change in positions of belt anchor for front row occupants.   |
| 7.3       | Any other parameter can be considered as criteria for extension of approval if it is mutually agreeable to the testing agency and the vehicle manufacturer.   |
| 7.4       | For deciding on the worst case or requirement of retest/partial test for extension of an existing type approval, the appropriate available data (i.e. test results/test reports/videos/pictures etc.) provided by the manufacturer may be used with the approval of the test agency   |

| <b>ANNEX 1</b>        |  |
|-----------------------|--|
| <b>TEST PROCEDURE</b> |  |
| <b>1.</b>             | <b>INSTALLATION AND PREPARATION OF THE VEHICLE</b>   |
| 1.1                   | <p>Testing ground</p> <p>The test area shall be large enough to accommodate the run-up track, barrier and technical installations necessary for the test. The last part of the track, for at least 5m before the barrier, shall be horizontal, flat and smooth.</p>  |
| 1.2                   | <p>Barrier</p> <p>The barrier shall consist of a block of reinforced concrete not less than 3 m wide in front and not less than 1.5 m high. The barrier shall be of such thickness that it weighs at least 70 metric tons. The front face shall be flat, vertical and perpendicular to the axis of the run-up track. It shall be covered with plywood boards <math>20 \pm 2</math> mm thick, in good condition. A structure on a steel plate at least 25 mm thick may be placed between the plywood board and the barrier. A barrier with different characteristics may likewise be used, provided that the area of the impact surface is greater than the frontal crash area of the vehicle being tested and provided that it gives equivalent results.</p> |
| 1.3                   | Orientation of the barrier   |
| 1.3.1                 | <p>Alignment of the vehicle to the barrier.</p> <p>It shall reach the obstacle on a course perpendicular to the collision wall; the maximum lateral misalignment tolerated between the vertical median line of the front of the vehicle and the vertical median line of the collision wall is <math>\pm 30</math> cm.</p>  |
| 1.4                   | State of vehicle   |
| 1.4.1                 | <p>General specification</p> <p>The test vehicle shall be representative of the series production, shall include all the equipment normally fitted and shall be in normal running order. Some components may be replaced by equivalent masses where this substitution clearly has no noticeable effect on the results measured under paragraph 6 below.</p> <p>It shall be allowed by agreement between manufacturer and Test Agency to modify the fuel system so that an appropriate amount of fuel can be used to run the engine or the electrical energy conversion system.</p>   |
| 1.4.2                 | Mass of vehicle  |
| 1.4.2.1               | For the test, the mass of the vehicle submitted shall be the unladen kerb mass;  |

|         |   |
|---------|---|
| 1.4.2.2 | The fuel tank shall be filled with water to mass equal to 90 per cent of the mass of a full load of fuel as specified by the manufacturer with a tolerance of $\pm 1$ per cent; This requirement does not apply to hydrogen fuel tanks.   |
| 1.4.2.3 | All the other systems (brake, cooling ...) may be empty in this case, the mass of the liquids shall be compensated;   |
| 1.4.2.4 | If the mass of the measuring apparatus on board the vehicle exceeds the 25 kg allowed; it may be compensated by reductions which have no noticeable effect on the results measured under paragraph 6 below.   |
| 1.4.2.5 | The mass of the measuring apparatus shall not change each axle reference load by more than 5%, each variation not exceeding 20 kg.  |
| 1.4.2.6 | The mass of the vehicle resulting from the provisions of paragraph 1.4.2.1. above shall be indicated in the report.   |
| 1.4.3   | Passenger compartment adjustments   |
| 1.4.3.1 | Position of steering wheel<br><br>The steering wheel, if adjustable, shall be placed in the normal position indicated by the manufacturer or, in the absence of any particular recommendation by the manufacturer, midway between the limits of its range(s) of adjustment. At the end of the propelled travel, the steering wheel shall be left free, with its spokes in the position which according to the manufacturer corresponds to straight-ahead travel of the vehicle. |
| 1.4.3.2 | Glazing<br><br>The movable glazing of the vehicle shall be in the closed position. For test measurement purposes and in agreement with the manufacturer, it may be lowered, provided that the position of the operating handle corresponds to the closed position.  |
| 1.4.3.3 | Gear-change lever position<br><br>The gear-change lever shall be in the neutral position. If the vehicle is propelled by its own engine, then the gear-change lever position shall be defined by the manufacturer.  |
| 1.4.3.4 | Pedals<br><br>The pedals shall be in their normal position of rest. If adjustable, they shall be set in their mid-position unless another position is specified by the manufacturer.  |
| 1.4.3.5 | Doors<br><br>The doors shall be closed but not locked.  |

|             |   |
|-------------|---|
| 1.4.3.5.1   | In the case of vehicles equipped with an automatically activated door locking system, the system shall be activated at the start of propulsion of the vehicle in order to lock the doors automatically before the moment of impact. At the choice of the manufacturer, the doors shall be locked manually before the start of propulsion of the vehicle.  |
| 1.4.3.5.2   | In the case of vehicles equipped with an automatically activated door locking system that is installed optionally and/or which can be deactivated by the driver, one of the following two procedures shall be used at the choice of the manufacturer:   |
| 1.4.3.5.2.1 | The system shall be activated at the start of propulsion of the vehicle in order to lock the doors automatically before the moment of impact. At the choice of the manufacturer, the doors shall be locked manually before the start of propulsion of the vehicle.  |
| 1.4.3.5.2.2 | The side doors on the driver side shall be unlocked and the system overridden for these doors; for the side doors on the passenger side, the system may be activated in order to lock these doors automatically before the moment of impact. At the choice of the manufacturer, these doors shall be locked manually before the start of propulsion of the vehicle. This test is deemed to be fulfilled, if the unlocked and locked doors are reversed. |
| 1.4.3.6     | <p>Opening roof</p> <p>If an opening or removable roof is fitted, it shall be in place and in the closed position. For test measurement purposes and in agreement with the manufacturer, it may be open.</p>  |
| 1.4.3.7     | <p>Sun-visor</p> <p>The sun-visors shall be in the stowed position.</p>   |
| 1.4.3.8     | <p>Rear-view mirror</p> <p>The interior rear-view mirror shall be in the normal position of use.</p>  |
| 1.4.3.9     | <p>Arm-rests</p> <p>Arm-rests at the front and rear, if movable, shall be in the lowered position, unless this is prevented by the position of the dummies in the vehicles.</p>   |
| 1.4.3.10    | <p>Head restraints</p> <p>Head restraints adjustable for height shall be in their appropriate position as defined by the manufacturer. In the absence of any particular recommendation from the manufacturer, then the head restraints shall be in their uppermost position for the fiftieth percentile male and in the lowermost position for the fifth percentile female dummy.</p>   |

|            |   |
|------------|---|
| 1.4.3.11   | Seats   |
| 1.4.3.11.1 | <p>Position of front driver seat</p> <p>Seats adjustable longitudinally shall be placed so that their "H" point, determined in accordance with the procedure set out in AIS-097, as amended from time to time, is in the middle position of travel or in the nearest locking position thereto, and at the height position defined by the manufacturer (if independently adjustable for height). In the case of a bench seat, the reference shall be to the "H" point of the driver's place.</p>                                   |
| 1.4.3.11.2 | <p>Position of front passenger seat</p> <p>Seats adjustable longitudinally shall be placed so that their "H" point, determined in accordance with the procedure set out in AIS-097, is:</p>   |
|            | <p>(a) In the position given by the manufacturer, which shall be forward of the middle position of travel; or</p>   |
|            | <p>(b) In the absence of any particular recommendation from the manufacturer, as near as possible to a position which is midway between the forward most position of the seat and the centre position of its travel.</p> <p>Any support system shall be adjusted as defined by the manufacturer. In the absence of any particular recommendation from the manufacturer, then any support system (e.g. seat cushion length and tilt adjustment) shall be in its retracted/ lowermost position.</p>                                 |
| 1.4.3.11.3 | <p>Position of the front seat-backs</p> <p>If adjustable, the seat-backs shall be adjusted so that the resulting inclination of the torso of the dummy is as close as possible to that recommended by the manufacturer for normal use or, in the absence of any particular recommendation by the manufacturer, to 25° towards the rear from the vertical. For the fifth percentile female dummy, the seat back may be adjusted to a different angle, if this is needed to respect the requirements of Annex 3, Paragraph 3.1.</p> |
| 1.4.3.11.4 | <p>Rear seats</p> <p>If adjustable, the rear seats or rear bench seats shall be placed in the rearmost position.</p>  |
| 1.4.4      | Electric power train adjustment   |
| 1.4.4.1    | Procedures for SOC Adjustment.  |
| 1.4.4.1.1  | The adjustment of SOC shall be conducted at an ambient temperature of $20 \pm 10^{\circ}\text{C}$ .   |

|           |   |
|-----------|---|
| 1.4.4.1.2 | The SOC shall be adjusted according to one of the following procedures as applicable. Where different charging procedures are possible, the REESS shall be charged using the procedure which yields the highest SOC:  |
|           | (a) For a vehicle with a REESS designed to be externally charged, the REESS shall be charged to the highest SOC in accordance with the procedure specified by the manufacturer for normal operation until the charging process is normally terminated.  |
|           | (b) For a vehicle with a REESS designed to be charged only by an energy source on the vehicle, the REESS shall be charged to the highest SOC which is achievable with normal operation of the vehicle. The manufacturer shall advise on the vehicle operation mode to achieve this SOC.   |
| 1.4.4.1.3 | When the vehicle is tested, the SOC shall be no less than 95% of the SOC according to Paragraphs 1.4.4.1.1. and 1.4.4.1.2. for REESS designed to be externally charged and shall be no less than 90% of SOC according to Paragraphs 1.4.4.1.1. and 1.4.4.1.2. for REESS designed to be charged only by an energy source on the vehicle. The SOC will be confirmed by a method provided by the manufacturer.                                 |
| 1.4.4.2   | The electric power train shall be energized with or without the operation of the original electrical energy sources (e.g. engine-generator, REESS or electric energy conversion system), however:   |
| 1.4.4.2.1 | By the agreement between Test Agency and manufacturer it shall be permissible to perform the test with all or parts of the electric power train not being energized insofar as there is no negative influence on the test result. For parts of the electrical power train not energized, the protection against electric shock shall be proved by either physical protection or isolation resistance and appropriate additional evidence.   |
| 1.4.4.2.2 | In the case where an automatic disconnect is provided, at the request of the manufacturer it shall be permissible to perform the test with the automatic disconnect being triggered. In this case it shall be demonstrated that the automatic disconnect would have operated during the impact test. This includes the automatic activation signal as well as the galvanic separation considering the conditions as seen during the impact. |
| <b>2.</b> | <b>DUMMIES</b>  |
| 2.1       | Front seats   |
| 2.1.1     | A dummy corresponding to the specifications for Hybrid III fiftieth percentile male dummy meeting the specifications for its adjustment shall be installed in the driver seat in accordance with the conditions set out in Annex 3. A dummy corresponding to the specifications for Hybrid III fifth percentile female dummy* meeting the specifications for its  |

|           |  |
|-----------|--|
|           | adjustment shall be installed in the passenger seat in accordance with the conditions set out in Annex 3.  |
| 2.1.2     | The car will be tested with restraint systems, as provided by the manufacturer.  |
| <b>3.</b> | <b>PROPULSION AND COURSE OF VEHICLE</b>  |
| 3.1       | The vehicle shall be propelled by its own engine or by any other propelling device;  |
| 3.2       | At the moment of impact the vehicle shall no longer be subject to the action of any additional steering or propelling device.  |
| 3.3       | The course of the vehicle shall be such that it satisfies the requirements of paragraphs 1.2. and 1.3.1 of this Annexure.  |
| <b>4.</b> | <b>TEST SPEED</b>  |
|           | Vehicle speed at the moment of impact shall be 50 -0/ +1 km/h. However, if the test was performed at a higher impact speed and the vehicle met the requirements, the test shall be considered satisfactory.  |
| <b>5.</b> | <b>MEASUREMENTS TO BE MADE ON DUMMIES IN FRONT SEATS</b>   |
| 5.1       | All the measurements necessary for the verification of the performance criteria shall be made with measurement systems corresponding to the specifications of Annex 5.   |
| 5.2       | The different parameters shall be recorded through independent data channels of the following CFC (Channel Frequency Class):   |
| 5.2.1     | Measurements in the head of the dummy<br>The acceleration (a) referring to the centre of gravity is calculated from the tri-axial components of the acceleration measured with a CFC of 1000.  |
|           | *The technical specifications and detailed drawings of Hybrid III with the principal dimensions of a 5 <sup>th</sup> percentile female dummy and the specifications for their adjustment for this test are deposited with the Secretary-General of the United Nations and may be consulted on request at the secretariat to the Economic Commission for Europe, Palais des Nations, Geneva, Switzerland. |
| 5.2.2     | Measurements in the neck of the dummy  |
| 5.2.2.1   | The axial tensile force and the fore/aft shear force at the neck/head interface are measured with a CFC of 1000.   |
| 5.2.2.2   | The bending moment about a lateral axis at the neck/head interface are measured with a CFC of 600.   |

|           |  |
|-----------|--|
| 5.2.3     | Measurements in the thorax of the dummy<br><br>The chest deflection between the sternum and the spine is measured with a CFC of 180.   |
| 5.2.4     | Measurements in the femur of the dummy   |
| 5.2.4.1   | The axial compressive force is measured with a CFC of 600.   |
| <b>6.</b> | <b>MEASUREMENTS TO BE MADE ON THE VEHICLE</b>  |
| 6.1       | To enable the simplified test described in Annex 4 to be carried out, the deceleration time history of the structure shall be determined on the basis of the value of the longitudinal accelerometers at the base of one of the "B" pillars of the vehicle with a CFC of 180 by means of data channels corresponding to the requirements set out in Annex 5; |
| 6.2       | The speed time history which will be used in the test procedure described in Annex 4 shall be obtained from the longitudinal accelerometer at the "B" pillar.  |
| <b>7.</b> | <b>EQUIVALENT PROCEDURES</b>   |
| 7.1       | Alternative procedures may be permitted at the discretion of the Test Agency provided equivalence can be demonstrated. A report shall be attached to the approval documentation describing the method used and the results obtained or the reason for not carrying out the test.   |
| 7.2       | Responsibility for demonstrating the equivalence of the alternative method shall rest with the manufacturer wishing to use such a method.  |

| <b>ANNEX 2</b>                               |  |
|--|--|
| <b>DETERMINATION OF PERFORMANCE CRITERIA</b> |  |
| <b>1.</b>                                    | <b>HEAD PERFORMANCE CRITERION (HPC<sub>36</sub>)</b>   |
| 1.1  | The Head Performance Criterion (HPC <sub>36</sub> ) is considered to be satisfied when, during the test, there is no contact between the head and any vehicle component.   |
| 1.2  | <p>If, during the test, there is contact between the head and any vehicle component, a calculation of HPC is made, on the basis of the acceleration (a), measured according to paragraph 5.2.1. of Annex 1, by the following expression:</p> $HPC = (t_2 - t_1) \left[ \frac{1}{t_2 - t_1} \int_{t_1}^{t_2} a dt \right]^{2.5}$ <p>in which:</p> |
| 1.2.1  | The term "a" is the resultant acceleration measured according to paragraph 5.2.1. of Annex 1 and is measured in units of gravity, g (1 g = 9.81 m/s <sup>2</sup> );  |
| 1.2.2  | If the beginning of the head contact can be determined satisfactorily, t <sub>1</sub> and t <sub>2</sub> are the two time instants, expressed in seconds, defining an interval between the beginning of the head contact and the end of the recording for which the value of HPC is maximum;   |
| 1.2.3  | If the beginning of the head contact cannot be determined, t <sub>1</sub> and t <sub>2</sub> are the two time instants, expressed in seconds, defining a time interval between the beginning and the end of the recording for which the value of HPC is maximum;   |
| 1.2.4  | Values of HPC for which the time interval (t <sub>1</sub> - t <sub>2</sub> ) is greater than 36 ms are ignored for the purposes of calculating the maximum value.  |
| 1.3  | The value of the resultant head acceleration during forward impact which is exceeded for 3 ms cumulatively is calculated from the resultant head acceleration measured according to paragraph 5.2.1. of Annex 1.   |
| <b>2.</b>                                    | <b>NECK INJURY CRITERIA (NIC)</b>  |
| 2.1  | These criteria are determined by, the axial tensile force and the fore/aft shear forces at the head/neck interface, expressed in kN and measured according to paragraph 5.2.2. of Annex 1.   |
| 2.2  | The neck bending moment criterion is determined by the bending moment, expressed in Nm, about a lateral axis at the head/neck interface and measured according to paragraph 5.2.2. of Annex 1.   |

|     |  |
|-----|--|
| 3.  | <b>THORAX COMPRESSION CRITERION (THCC) AND VISCOUS CRITERION (V * C)</b>   |
| 3.1 | The thorax compression criterion is determined by the absolute value of the thorax deformation, expressed in mm and measured according to paragraph 5.2.3. of Annex 1.   |
| 3.2 | The Viscous Criterion (V * C) is calculated as the instantaneous product of the compression and the rate of deflection of the sternum, measured according to paragraph 6. of this annex and also paragraph 5.2.3. of Annex 1.  |
| 4.  | <b>FEMUR FORCE CRITERION (FFC)</b>   |
| 4.1 | This criterion is determined by the compression load expressed in kN, transmitted axially on each femur of the dummy and measured according to paragraph 5.2.4. of Annex 1.  |
| 5.  | <b>PROCEDURE FOR CALCULATING THE VISCOUS CRITERIA (V * C) FOR HYBRID III DUMMY</b>   |
| 5.1 | The viscous criterion is calculated as the instantaneous product of the compression and the rate of deflection of the sternum. Both are derived from the measurement of sternum deflection.  |
| 5.2 | <p>The sternum deflection response is filtered once at CFC 180. The compression at time t is calculated from this filtered signal as:</p> $C(t) = D(t) / \text{constant},$ <p>where constant percentile male = 0.229 for the HIII 50<sup>th</sup><br/>and constant percentile female = 0.187 for the HIII 5<sup>th</sup></p> <p>The sternum deflection velocity at time t is calculated from the filtered deflection as:</p> $V_{(t)} = \frac{8(D_{(t+1)} - D_{(t-1)}) - (D_{(t+2)} - D_{(t-2)})}{12\partial t}$ <p>Where <math>D_{(t)}</math> is the deflection at time t in metres and <math>\partial t</math> is the time interval in seconds between the measurements of deflection. The maximum value of <math>\partial t</math> shall be <math>1.25 \times 10^{-4}</math> seconds. This calculation procedure is shown diagrammatically below:</p> |

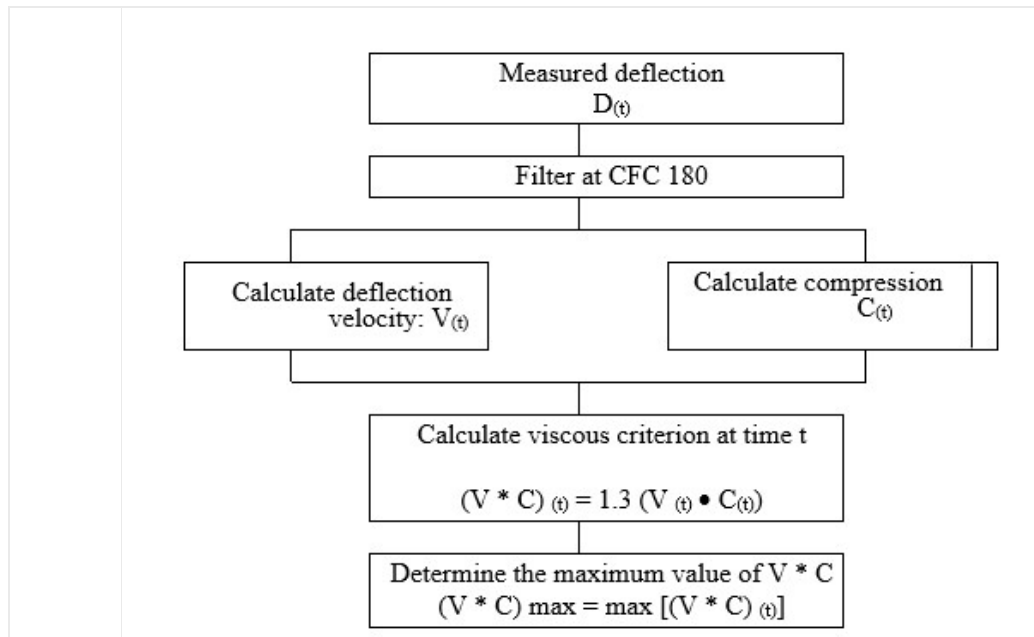

| <b>ANNEX 3</b>   |   |
|--|---|
| <b>ARRANGEMENT AND INSTALLATION OF DUMMIES AND ADJUSTMENT OF RESTRAINT SYSTEMS</b> |   |
| <b>1.</b>  | <b>ARRANGEMENT OF DUMMIES</b>   |
| 1.1  | <p><b>Separate seats</b></p> <p>The plane of symmetry of the dummy shall coincide with the vertical median plane of the seat.</p>   |
| 1.2  | <b>Front bench seat</b>   |
| 1.2.1  | <p>Driver</p> <p>The plane of symmetry of the dummy shall lie in the vertical plane passing through the steering wheel centre and parallel to the longitudinal median plane of the vehicle. If the seating position is determined by the shape of the bench, such seat shall be regarded as a separate seat.</p>  |
| 1.2.2  | <p>Outer passenger</p> <p>The plane of symmetry of the dummy shall be symmetrical with that of the driver dummy relative to the longitudinal median plane of the vehicle. If the seating position is determined by the shape of the bench, such seat shall be regarded as a separate seat.</p>  |
| 1.3  | <p>Bench seat for front passengers (not including driver)</p> <p>The planes of symmetry of the dummy shall coincide with the median planes of the seating positions defined by the manufacturer.</p>  |
| <b>2.</b>  | <b>INSTALLATION OF THE HIII FIFTIETH PERCENTILE MALE DUMMY ON THE DRIVER SEAT</b>   |
| 2.1  | <p><b>Head</b></p> <p>The transverse instrumentation platform of the head shall be horizontal within 2.5°. To level the head of the test dummy in vehicles with upright seats with non-adjustable backs, the following sequences shall be followed. First adjust the position of the "H" point within the limits set forth in paragraph 2.4.3.1. below to level the transverse instrumentation platform of the head of the test dummy. If the transverse instrumentation platform of the head is still not level, then adjust the pelvic angle of the test dummy within the limits provided in paragraph 2.4.3.2. below. If the transverse instrumentation platform of the head is still not level, then adjust the neck bracket of the test dummy the minimum amount necessary to ensure that the transverse instrumentation platform of the head is horizontal within 2.5°.</p> |

|         |   |
|---------|---|
| 2.2     | <b>Arms</b>   |
| 2.2.1   | The driver's upper arms shall be adjacent to the torso with the centrelines as close to a vertical plane as possible.   |
| 2.3     | <b>Hands</b><br><br>The palms of the driver test dummy shall be in contact with the outer part of the steering wheel rim at the rim's horizontal centreline. The thumbs shall be over the steering wheel rim and shall be lightly taped to the steering wheel rim so that if the hand of the test dummy is pushed upward by a force of not less than 9 N and not more than 22 N, the tape shall release the hand from the steering wheel rim. |
| 2.4     | <b>Torso</b>  |
| 2.4.1   | In vehicles equipped with bench seats, the upper torso of the driver test dummy shall rest against the seat back. The midsagittal plane of the driver dummy shall be vertical and parallel to the vehicle's longitudinal centreline, and pass through the centre of the steering wheel rim.   |
| 2.4.2   | In vehicles equipped with individual seats, the upper torso of the driver test dummy shall rest against the seat back. The midsagittal plane of the driver dummy shall be vertical and shall coincide with the longitudinal centreline of the individual seat.  |
| 2.4.3   | Lower torso   |
| 2.4.3.1 | "H" point<br><br>The "H" point of the driver test dummy shall coincide within 13 mm in the vertical dimension and 13 mm in the horizontal dimension, with a point 6 mm below the position of the "H" point determined using the procedure described in AIS-097 except that the length of the lower leg and thigh segments of the "H" point machine shall be adjusted to 414 and 401 mm, instead of 417 and 432 mm respectively.               |
| 2.4.3.2 | Pelvic angle<br><br>As determined using the pelvic angle gauge (GM) drawing 78051-532 incorporated by reference in Part 572 which is inserted into the "H" point gauging hole of the dummy, the angle measured from the horizontal on the 76.2 mm (3 inch) flat surface of the gauge shall be 22.5 degrees plus or minus 2.5 degrees.   |
| 2.5     | <b>Legs</b><br><br>The upper legs of the driver test dummy shall rest against the seat cushion to the extent permitted by placement of the feet. The initial distance between the outboard knee clevis flange surfaces shall be 270 mm $\pm$ 10 mm. To the extent practicable, the left leg of the driver dummy shall be in vertical longitudinal planes. To the extent practicable, the right leg of   |

|           |  |
|-----------|--|
|           | the driver dummy shall be in a vertical plane. Final adjustment to accommodate placement of feet in accordance with paragraph 2.6. for various passenger compartment configurations is permitted.  |
| 2.6       | <b>Feet</b>  |
| 2.6.1     | The right foot of the driver test dummy shall rest on the undepressed accelerator with the rearmost point of the heel on the floor surface in the plane of the pedal. If the foot cannot be placed on the accelerator pedal, it shall be positioned perpendicular to the tibia and placed as far forward as possible in the direction of the centreline of the pedal with the rearmost point of the heel resting on the floor surface. The heel of the left foot shall be placed as far forward as possible and shall rest on the floor pan. The left foot shall be positioned as flat as possible on the toe board. The longitudinal centreline of the left foot shall be placed as parallel as possible to the longitudinal centreline of the vehicle. For vehicles equipped with a footrest, it shall be possible at the request of the manufacturer to place the left foot on the footrest. In this case the position of the left foot is defined by the footrest. |
| 2.7       | The measuring instruments installed shall not in any way affect the movement of the dummy during impact.   |
| 2.8       | The temperature of the dummy and the system of measuring instruments shall be stabilized before the test and maintained so far as possible within a range between 19 °C and 22.2 °C.   |
| 2.9       | <b>Dummy HIII fiftieth percentile clothing</b>   |
| 2.9.1     | The instrumented dummy will be clothed in formfitting cotton stretch garments with short sleeves and mid-calf length trousers specified in FMVSS 208, drawings 78051-292 and 293 or their equivalent.  |
| 2.9.2     | A size 11XW shoe, which meets the configuration size, sole and heel thickness specifications of the United States of America military standard MIL S 13192, revision P and whose weight is $0.57 \pm 0.1$ kg, shall be placed and fastened on each foot of the test dummy.   |
| <b>3.</b> | <b>INSTALLATION OF THE HYBRID III FIFTH PERCENTILE FEMALE DUMMY ON THE PASSENGER SEAT.</b><br><br>The longitudinal and vertical dimension of "H" point are described as ( $X_{50thM}$ , $Z_{50thM}$ ) and the longitudinal and vertical dimension of "H5 <sup>th</sup> " point are described as ( $X_{5thF}$ , $Z_{5thF}$ ). $X_{SCL}$ is defined as the horizontal distance between the "H" point and the most forward point on the seat cushion (see Figure 1). Use the following formula to calculate the "H 5 <sup>th</sup> " point. Note that $X_{5thF}$ should always be more forward than the $X_{50thM}$ .<br><br>$X_{5thF} = X_{50thM} + (93 \text{ mm} - 0.323 \times X_{SCL})$ $Z_{5thF} = Z_{50thM}$   |

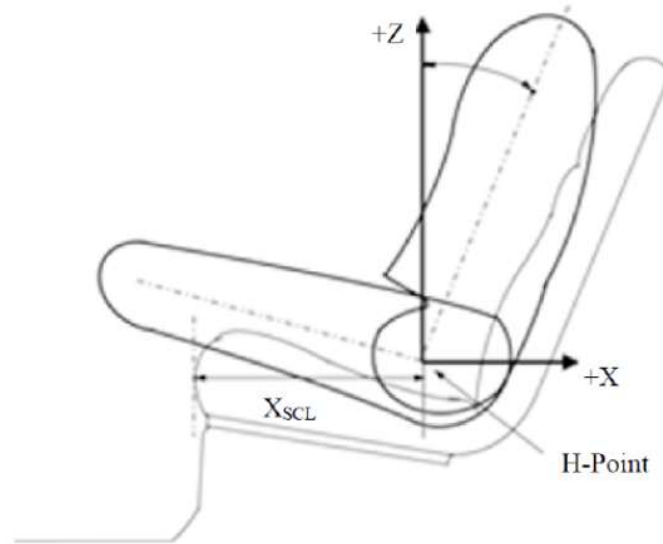
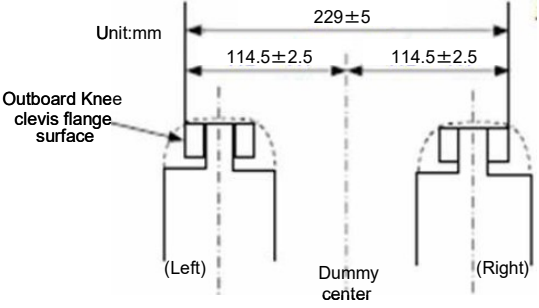

Figure 1

|       |  |
|-------|--|
| 3.1   | <p><b>Head</b></p> <p>The transverse instrumentation platform of the head shall be horizontal within 2.5°. To level the head of the test dummy in vehicles with upright seats with non-adjustable backs, the following sequences shall be followed. First adjust the position of the "H 5<sup>th</sup>" point within the limits set forth in paragraph 3.4.3.1. below to level the transverse instrumentation platform of the head of the test dummy. If the transverse instrumentation platform of the head is still not level, then adjust the pelvic angle of the test dummy within the limits provided in paragraph 3.4.3.2. below. If the transverse instrumentation platform of the head is still not level, then adjust the neck bracket of the test dummy the minimum amount necessary to ensure that the transverse instrumentation platform of the head is horizontal within 2.5°.</p> |
| 3.2   | <p><b>Arms</b></p>   |
| 3.2.1 | <p>The passenger's upper arms shall be in contact with the seat back and the sides of the torso.</p>   |
| 3.3   | <p><b>Hands</b></p>  |
| 3.3.1 | <p>The palms of the passenger test dummy shall be in contact with outside of thigh. The little finger shall be in contact with the seat cushion.</p>   |
| 3.4   | <p><b>Torso</b></p>  |
| 3.4.1 | <p>In vehicles equipped with bench seats, the upper torso of the passenger test dummy shall rest against the seat back. The midsagittal plane of the passenger dummy shall be vertical and parallel to the vehicle's longitudinal centreline and the same distance from the vehicle's longitudinal centreline as the midsagittal plane of the driver dummy.</p>  |

|  |  |
|--|--|
| 3.4.2  | In vehicles equipped with individual seats, the upper torso of the passenger test dummy shall rest against the seat back. The midsagittal plane of the passenger dummy shall be vertical and shall coincide with the longitudinal centreline of the individual seat.   |
| 3.4.3  | Lower torso  |
| 3.4.3.1  | <p>"H 5<sup>th</sup>" point</p> <p>The "H 5<sup>th</sup>" point of passenger test dummy shall coincide within 13 mm in the horizontal dimension, of the "H 5<sup>th</sup>" point determined using the procedure described in AIS-097, as amended from time to time, and paragraph 3. above.</p>  |
| 3.4.3.2  | <p>Pelvic angle</p> <p>As determined using the pelvic angle gauge (GM) drawing 78051-532 incorporated by reference in Part 572 which is inserted into the "H" point gauging hole of the dummy, the angle measured from the horizontal on the 76.2 mm (3 inch) flat surface of the gauge shall be 20 degrees plus or minus 2.5 degrees.</p>   |
| 3.5  | <p><b>Legs</b></p> <p>The upper legs of the passenger test dummy shall rest against the seat cushion to the extent permitted by placement of the feet. The initial distance between the outboard knee clevis flange surfaces shall be <math>229 \pm 5</math> mm as shown in Figure 2. To the extent practicable, both legs of the passenger dummy shall be in vertical longitudinal planes. Final adjustment to accommodate placement of feet in accordance with paragraph 3.6. for various passenger compartment configurations is permitted.</p> |
| <b>The initial knee distance of Hybrid III fifth percentile female</b>   |  |
|  <p style="text-align: center;">Figure 2</p> |  |
| 3.6  | <b>Feet</b>  |
|  | The legs shall be positioned as distant as possible from the front end of the seat cushion while the thighs are kept in contact with the seat cushion as shown in Fig. (a). As shown in Fig. (b), each leg shall be lowered until the foot comes in contact with the floor while the foot and tibia are kept   |

in a right angle to one another and the thigh inclination angle kept constant. When each heel is in contact with the floor, the foot shall be rotated so that the toe comes as much in contact as possible with the floor as shown in Fig. (c).

If it is not possible to have each foot in contact with the floor, the foot shall be lowered until the calf comes in contact with the front end of the seat cushion or the back of the foot comes in contact with the vehicle interior. The foot shall be kept as parallel as possible to the floor as shown in Fig. (d).

In case of interference from a vehicle body protrusion, the foot shall be rotated as minimally as possible around the tibia. In case interference still remains, the femur shall be rotated to resolve or minimize the interference. The foot shall be moved inward or outward while the separation distance between the knees is kept constant.

**Figure (a)**



**Figure (b)**



**Figure (c)**

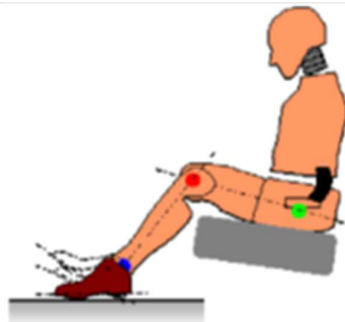

**Figure (d)**

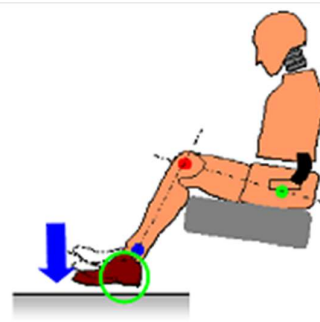

**Figure 3**

3.7 The measuring instruments installed shall not in any way affect the movement of the dummy during impact.

3.8 The temperature of the dummies and the system of measuring instruments shall be stabilized before the test and maintained so far as possible within a range between 19 °C and 22.2 °C.

|           |   |
|-----------|---|
| 3.6       | <b>Dummy HIII fifth percentile clothing</b>   |
| 3.9.1     | The instrumented dummy will be clothed in formfitting cotton stretch garments with short sleeves and mid-calf length trousers specified in FMVSS 208, drawings 78051-292 and 293 or their equivalent.   |
| 3.9.2     | A size 7.5 W small female size shoe, which meets the configuration size, sole and heel thickness specifications of the United States of America military standard MIL-S-21711E, revision P and whose weight is $0.41 \pm 0.09$ kg, shall be placed and fastened on each foot of the test dummies.   |
| <b>4.</b> | <b>ADJUSTMENT OF RESTRAINT SYSTEM</b>   |
|           | <p>The dummy jacket shall be installed at the appropriate position where the bolt hole of the neck lower bracket and the work hole of the dummy jacket should be at the same position. With the test dummy at its designated seating position as specified by the appropriate requirements of paragraphs 2.1. through 2.6. and paragraphs 3.1. to 3.6. above, place the belt around the test dummy and fasten the latch. Remove all slack from the lap belt. Pull the upper torso webbing out of the retractor and allow it to retract. Repeat this operation four times. The shoulder belt should be at the position between the area which shall not be taken off of shoulder and shall not come in contact with the neck. The seat belt path shall be positioned: for Hybrid III fiftieth percentile male dummy, the hole of the outer side dummy jacket shall not be fully hidden by the seat belt. For Hybrid III fifth percentile female dummy, the seat belt shall lie between the breasts. Apply a 9 to 18 N tension load to the lap belt. If the belt system is equipped with a tension-relieving device, introduce the maximum amount of slack into the upper torso belt that is recommended by the manufacturer for normal use in the owner's manual for the vehicle. If the belt system is not equipped with a tension-relieving device, allow the excess webbing in the shoulder belt to be retracted by the rewind force of the retractor. Where the safety belt and safety belt anchorages are located such that the belt does not lie as required above then the safety belt may be manually adjusted and retained by tape.</p> |

| <b>ANNEX 4</b>                     |  |
|------------------------------------|--|
| <b>TEST PROCEDURE WITH TROLLEY</b> |  |
| <b>1.</b>                          | <b>TEST INSTALLATION AND PROCEDURE</b>   |
| 1.1                                | <p><b>Trolley</b></p> <p>The trolley shall be so constructed that no permanent deformation appears after the test. It shall be so guided that, during the impact phase, the deviation in the vertical plane does not exceed 5° and 2° in the horizontal plane.</p> |
| 1.2                                | <b>State of the structure</b>  |
| 1.2.1                              | <p>General</p> <p>The structure tested shall be representative of the series production of the vehicles concerned. Some components may be replaced or removed where such replacement or removal clearly has no effect on the test results.</p>                     |
| 1.2.2                              | <p>Adjustments</p> <p>Adjustments shall conform to those set out in paragraph 1.4.3. of Annex 1 to this Standard, taking into account what is stated in paragraph 1.2.1. above.</p>  |
| 1.3                                | <b>Attachment of the structure</b>   |
| 1.3.1                              | The structure shall be firmly attached to the trolley in such a way that no relative displacement occurs during the test.  |
| 1.3.2                              | The method used to fasten the structure to the trolley shall not have the effect of strengthening the seat anchorages or restraint devices, or of producing any abnormal deformation of the structure.   |
| 1.3.3                              | The attachment device recommended is that whereby the structure rests on supports placed approximately in the axis of the wheels or, if possible, whereby the structure is secured to the trolley by the fastenings of the suspension system.                      |
| 1.3.4                              | The angle between the longitudinal axis of the vehicle and the direction of motion of the trolley shall be $0^\circ \pm 2^\circ$ .   |
| 1.4                                | <p><b>Dummies</b></p> <p>The dummies and their positioning shall conform to the specifications in Annex 1, paragraph 2.</p>  |

|       |  |
|-------|--|
| 1.5   | <b>Measuring apparatus</b>   |
| 1.5.1 | <p>Deceleration of the structure</p> <p>The position of the transducers measuring the deceleration of the structure during the impact shall be parallel to the longitudinal axis of the trolley according to the specifications of Annex 5 (CFC 180).</p>  |
| 1.5.2 | <p>Measurements to be made on the dummies</p> <p>All the measurements necessary for checking the listed criteria are set out in Annex 1, paragraph 5.</p>  |
| 1.6   | <p><b>Deceleration curve of the structure</b></p> <p>The deceleration curve of the structure during the impact phase shall be such that the "variation of speed in relation to time" curve obtained by integration at no point differs by more than <math>\pm 1</math> m/s from the "variation of speed in relation to time" reference curve of the vehicle concerned as defined in appendix to this annex. A displacement with regard to the time axis of the reference curve may be used to obtain the structure velocity inside the corridor.</p> |
| 1.7   | <p><b>Reference curve <math>\Delta V = f(t)</math> of the vehicle concerned</b></p> <p>This reference curve is obtained by integration of the deceleration curve of the vehicle concerned measured in the frontal collision test against a barrier as provided for in paragraph 6. of Annex 1 to this Standard.</p>  |
| 1.8   | <p><b>Equivalent method</b></p> <p>The test may be performed by some other method than that of deceleration of a trolley, provided that such method complies with the requirement concerning the range of variation of speed described in paragraph 1.6. above.</p>  |

ANNEX 4 – APPENDIX

EQUIVALENCE CURVE - TOLERANCE BAND FOR CURVE  $\Delta V = f(t)$

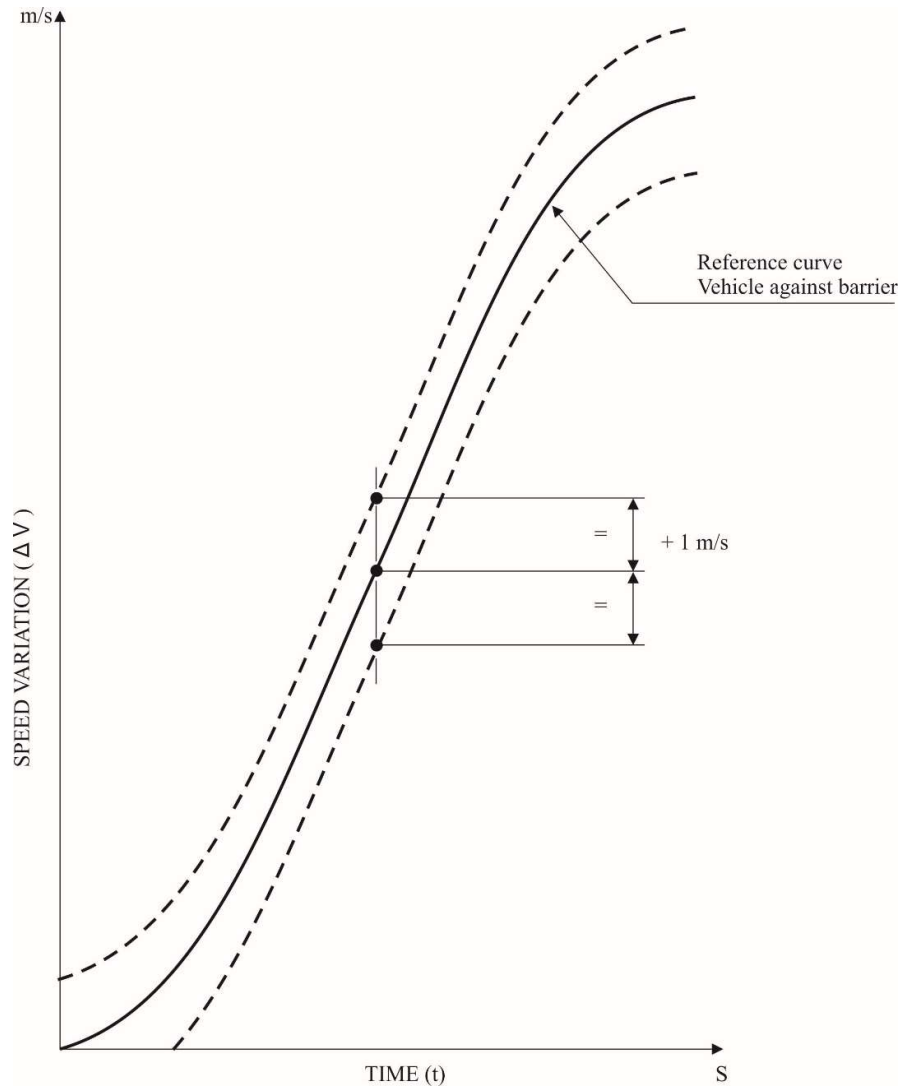

Figure 4

| <b>ANNEX 5</b>  |   |
|---|---|
| <b>TECHNIQUE OF MEASUREMENT IN MEASUREMENT TESTS:<br/>INSTRUMENTATION</b> |   |
| <b>1.</b>   | <b>DEFINITIONS</b>  |
| 1.1   | <p><b>Data channel</b></p> <p>A data channel comprises all the instrumentation from a transducer (or multiple transducers whose outputs are combined in some specified way) up to and including any analysis procedures that may alter the frequency content or the amplitude content of data.</p>            |
| 1.2   | <p><b>Transducer</b></p> <p>The first device in a data channel used to convert a physical quantity to be measured into a second quantity (such as an electrical voltage) which can be processed by the remainder of the channel.</p>  |
| 1.3   | <p><b>Channel Amplitude Class (CAC)</b></p> <p>The designation for a data channel that meets certain amplitude characteristics as specified in this annex. The CAC number is numerically equal to the upper limit of the measurement range.</p>   |
| 1.4   | <p><b>Characteristic frequencies <math>F_H</math>, <math>F_L</math>, <math>F_N</math></b></p> <p>These frequencies are defined in Figure 1 of this annex.</p>   |
| 1.5   | <p><b>Channels Frequency Class (CFC)</b></p> <p>The channel frequency class is designated by a number indicating that the channel frequency response lies within the limits specified in Figure 1 of this annex. This number and the value of the frequency <math>F_H</math> in Hz are numerically equal.</p> |
| 1.6   | <p><b>Sensitivity coefficient</b></p> <p>The slope of the straight line representing the best fit to the calibration values determined by the method of least square within the channel amplitude class.</p>  |
| 1.7   | <p><b>Calibration factor of a data channel</b></p> <p>The mean value of the sensitivity coefficients evaluated over frequencies which are evenly spaced on a logarithmic scale between <math>F_L</math> and <math>\frac{F_H}{2.5}</math></p>  |
| 1.8   | <p><b>Linearity error</b></p> <p>The ratio, in per cent, of the maximum difference between the calibration value and the corresponding value read on the straight line defined in paragraph 1.6. above at the upper limit of the channel amplitude class.</p>   |

|           |  |
|-----------|--|
| 1.9       | <p><b>Cross sensitivity</b></p> <p>The ratio of the output signal to the input signal, when an excitation is applied to the transducer perpendicular to the measurement axis. It is expressed as a percentage of the sensitivity along the measurement axis.</p>   |
| 1.10      | <p><b>Phase delay time</b></p> <p>The phase delay time of a data channel is equal to the phase delay (in radians) of a sinusoidal signal, divided by the angular frequency of that signal (in radians/second).</p>   |
| 1.11      | <p><b>Environment</b></p> <p>The aggregate, at a given moment, of all external conditions and influences to which the data channel is subjected.</p>   |
| <b>2.</b> | <b>PERFORMANCE REQUIREMENTS</b>  |
| 2.1       | <p><b>Linearity error</b></p> <p>The absolute value of the linearity error of a data channel at any frequency in the CFC, shall be equal to or less than 2.5 per cent of the value of the CAC, over the whole measurement range.</p>   |
| 2.2       | <p><b>Amplitude against frequency</b></p> <p>The frequency response of a data channel shall lie within the limiting curves given in Figure 1 of this annex. The zero dB line is determined by the calibration factor.</p>  |
| 2.3       | <p><b>Phase delay time</b></p> <p>The phase delay time between the input and the output signals of a data channel shall be determined and shall not vary by more than <math>1/10 F_H</math> seconds between <math>0.03 F_H</math> and <math>F_H</math>.</p>  |
| 2.4       | <b>Time</b>  |
| 2.4.1     | <p>Time base</p> <p>A time base shall be recorded and shall at least give <math>1/100</math> s with an accuracy of 1 per cent.</p>   |
| 2.4.2     | <p>Relative time delay</p> <p>The relative time delay between the signal of two or more data channels, regardless of their frequency class, shall not exceed 1 ms excluding delay caused by phase shift.</p> <p>Two or more data channels of which the signals are combined shall have the same frequency class and shall not have relative time delay greater than <math>1/10 F_H</math> seconds.</p> <p>This requirement applies to analogue signals as well as to synchronization pulses and digital signals.</p> |

|           |  |
|-----------|--|
| 2.5       | <p><b>Transducer cross sensitivity</b></p> <p>The transducer cross sensitivity shall be less than 5 per cent in any direction.</p>   |
| 2.6       | <p><b>Calibration</b></p>  |
| 2.6.1     | <p>General</p> <p>A data channel shall be calibrated at least once a year against reference equipment traceable to known standards. The methods used to carry out a comparison with reference equipment shall not introduce an error greater than 1 per cent of the CAC. The use of the reference equipment is limited to the frequency range for which they have been calibrated. Subsystems of a data channel may be evaluated individually and the results factored into the accuracy of the total data channel. This can be done for example by an electrical signal of known amplitude simulating the output signal of the transducer which allows a check to be made on the gain factor of the data channel, excluding the transducer.</p> |
| 2.6.2     | <p>Accuracy of reference equipment for calibration</p> <p>The accuracy of the reference equipment shall be certified or endorsed by an official metrology service.</p>   |
| 2.6.2.1   | <p>Static calibration</p>  |
| 2.6.2.1.1 | <p>Accelerations</p> <p>The errors shall be less than <math>\pm 1.5</math> per cent of the channel amplitude class.</p>  |
| 2.6.2.1.2 | <p>Forces</p> <p>The error shall be less than <math>\pm 1</math> per cent of the channel amplitude class.</p>  |
| 2.6.2.1.3 | <p>Displacements</p> <p>The error shall be less than <math>\pm 1</math> per cent of the channel amplitude class.</p>   |
| 2.6.2.2   | <p>Dynamic calibration</p>   |
| 2.6.2.2.1 | <p>Accelerations</p> <p>The error in the reference accelerations expressed as a percentage of the channel amplitude class shall be less than <math>\pm 1.5</math> per cent below 400 Hz, less than <math>\pm 2</math> per cent between 400 Hz and 900 Hz, and less than <math>\pm 2.5</math> per cent above 900 Hz.</p>  |
| 2.6.2.3   | <p>Time</p> <p>The relative error in the reference time shall be less than <math>10^{-5}</math>.</p>   |

|       |  |
|-------|--|
| 2.6.3 | <p><b>Sensitivity coefficient and linearity error</b></p> <p>The sensitivity coefficient and the linearity error shall be determined by measuring the output signal of the data channel against a known input signal for various values of this signal. The calibration of the data channel shall cover the whole range of the amplitude class.</p> <p>For bi-directional channels, both the positive and negative values shall be used.</p> <p>If the calibration equipment cannot produce the required input owing to the excessively high values of the quantity to be measured, calibrations shall be carried out within the limits of the calibration standards and these limits shall be recorded in the test report.</p> <p>A total data channel shall be calibrated at a frequency or at a spectrum of frequencies having a significant value between <math>F_L</math> and <math>\frac{F_H}{2.5}</math>.</p> |
| 2.6.4 | <p><b>Calibration of the frequency response</b></p> <p>The response curves of phase and amplitude against frequency shall be determined by measuring the output signals of the data channel in terms of phase and amplitude against a known input signal, for various values of this signal varying between <math>F_L</math> and 10 times the CFC or 3,000 Hz, whichever is lower.</p>   |
| 2.7   | <p><b>Environmental effects</b></p> <p>A regular check shall be made to identify any environmental influence (such as electric or magnetic flux, cable velocity, etc.). This can be done for instance by recording the output of spare channels equipped with dummy transducers. If significant output signals are obtained corrective action shall be taken, for instance by replacement of cables.</p>   |
| 2.8   | <p><b>Choice and designation of the data channel</b></p> <p>The CAC and CFC define a data channel.</p> <p>The CAC shall be 1, 2 or 5 to a power of ten.</p>  |
| 3.    | <p><b>MOUNTING OF TRANSDUCERS</b></p> <p>Transducers should be rigidly secured so that their recordings are affected by vibration as little as possible. Any mounting having a lowest resonance frequency equal to at least 5 times the frequency <math>F_H</math> of the data channel considered shall be considered valid. Acceleration transducers in particular should be mounted in such a way that the initial angle of the real measurement axis to the corresponding axis of the reference axis system is not greater than <math>5^\circ</math> unless an analytical or experimental assessment of the effect of the mounting on the collected data is made. When multi-axial accelerations at a point are to be measured, each acceleration transducer axis should pass within 10 mm of that point, and the centre of seismic mass of each accelerometer should be within 30 mm of that point.</p>          |

|           |   |
|-----------|---|
| <b>4.</b> | <b>DATA PROCESSING</b>  |
| 4.1       | <p>Filtering</p> <p>Filtering corresponding to the frequencies of the data channel class may be carried out during either recording or processing of data. However, before recording, analogical filtering at a higher level than CFC should be effected in order to use at least 50 per cent of the dynamic range of the recorder and to reduce the risk of high frequencies saturating the recorder or causing aliasing errors in the digitalizing process.</p> |
| 4.2       | Digitalizing  |
| 4.2.1     | <p>Sampling frequency</p> <p>The sampling frequency should be equal to at least <math>8 F_H</math>.</p>   |
| 4.2.2     | <p>Amplitude resolution</p> <p>The size of digital words should be at least 7 bits and a parity bit.</p>  |

**5. PRESENTATION OF RESULTS**

The results should be presented on A4 size paper (ISO/R 216). Results presented as diagrams should have axes scaled with a measurement unit corresponding to a suitable multiple of the chosen unit (for example, 1, 2, 5, 10, 20 millimetres). SI units shall be used, except for vehicle velocity, where km/h may be used, and for accelerations due to impact where g, with  $g = 9.8 \text{ m/s}^2$ , may be used.

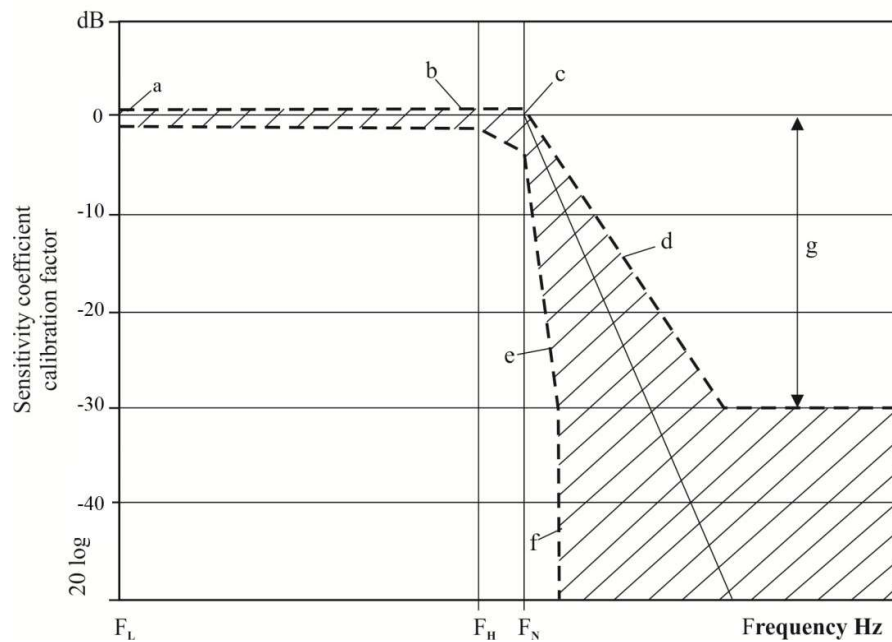

**Figure 5 - Frequency response curve**

| CFC  | $F_L$      | $F_H$ | $F_N$ | <u>N</u> | <u>Logarithmic scale</u> |           |
|------|------------|-------|-------|----------|--------------------------|-----------|
|      | Hz         | Hz    | Hz    |          |                          |           |
| 1000 | $\leq 0.1$ | 1000  | 1650  | a        | $\pm 0.5$                | dB        |
| 600  | $\leq 0.1$ | 600   | 1000  | b        | +0.5; -1                 | dB        |
| 180  | $\leq 0.1$ | 180   | 300   | c        | +0.5; -4                 | dB        |
| 60   | $\leq 0.1$ | 60    | 100   | d        | - 9                      | dB/octave |
|      |            |       |       | e        | - 24                     | dB/octave |
|      |            |       |       | f        | $\infty$                 |           |
|      |            |       |       | g        | - 30                     |           |

|                  |  |
|------------------|--|
|                  | <p><b>ANNEX 6</b></p> <p><b>TEST PROCEDURES FOR VEHICLES EQUIPPED WITH THE ELECTRIC POWER TRAIN</b></p>  |
|                  | <p>This annex describes test procedures to demonstrate compliance to the electrical safety requirements of paragraph 5.2.8. For example, megohmmeter or oscilloscope measurements are an appropriate alternative to the procedure described below for measuring isolation resistance. In this case it may be necessary to deactivate the on-board isolation resistance monitoring system.</p> <p>Before the vehicle impact test conducted, the high voltage bus voltage (<math>U_b</math>) (see Figure 1 below) shall be measured and recorded to confirm that it is within the operating voltage of the vehicle as specified by the vehicle manufacturer.</p> |
| <p><b>1.</b></p> | <p><b>TEST SETUP AND EQUIPMENT</b></p>   |
|                  | <p>If a high voltage disconnect function is used, measurements are to be taken from both sides of the device performing the disconnect function.</p> <p>However, if the high voltage disconnect is integral to the REESS or the energy conversion system and the high-voltage bus of the REESS or the energy conversion system is protected according to protection IPXXB following the impact test, measurements may only be taken between the device performing the disconnect function and the electrical loads.</p> <p>The voltmeter used in this test shall measure DC values and have an internal resistance of at least 10 MΩ.</p>                      |
| <p><b>2.</b></p> | <p><b>THE FOLLOWING INSTRUCTIONS MAY BE USED IF VOLTAGE IS MEASURED.</b></p> <p>After the impact test, determine the high voltage bus voltages (<math>U_b</math>, <math>U_1</math>, <math>U_2</math>) (see Figure 1 below).</p> <p>The voltage measurement shall be made not earlier than 10 seconds, but, not later than 60 seconds after the impact.</p> <p>This procedure is not applicable if the test is performed under the condition where the electric power train is not energized.</p>   |

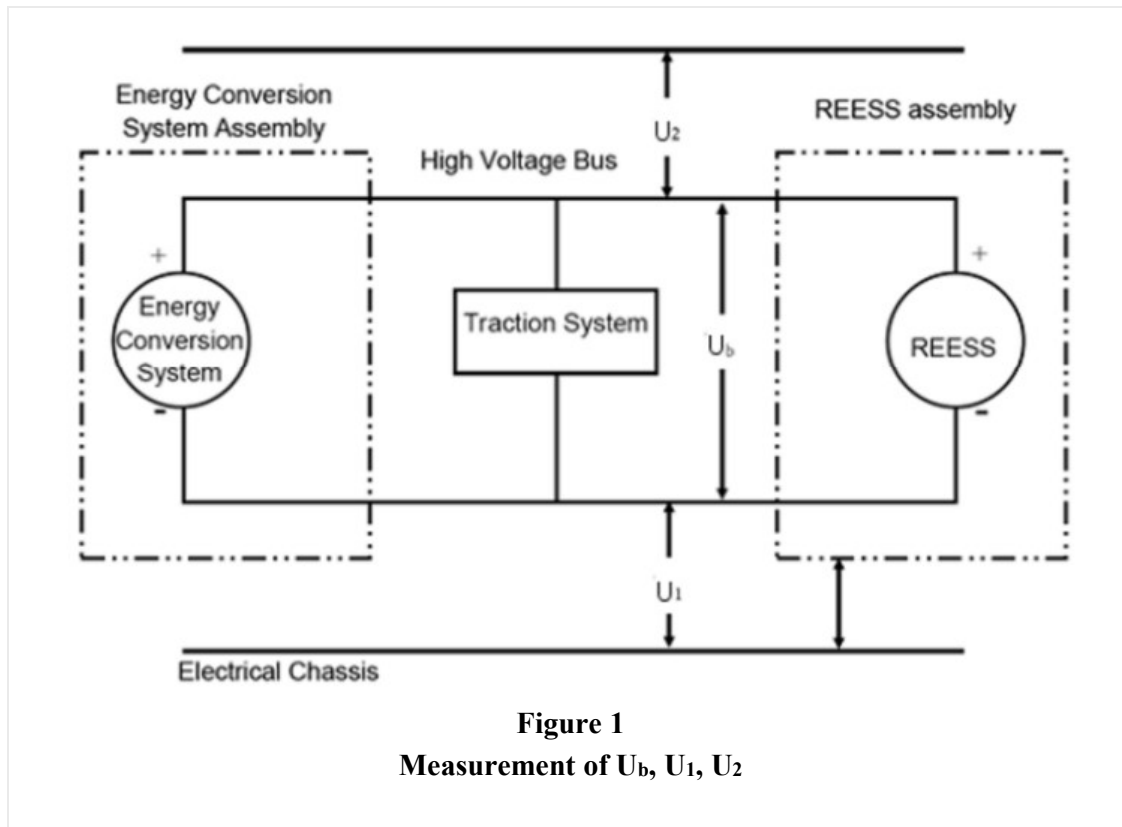

**Figure 1**  
**Measurement of  $U_b$ ,  $U_1$ ,  $U_2$**

|     |   |
|-----|---|
| 3.  | <p><b>ASSESSMENT PROCEDURE FOR LOW ELECTRICAL ENERGY</b></p> <p>Prior to the impact a switch <math>S_1</math> and a known discharge resistor <math>R_e</math> is connected in parallel to the relevant capacitance (ref. Figure 2 below).</p>   |
| (a) | <p>Not earlier than 10 seconds and not later than 60 seconds after the impact the switch <math>S_1</math> shall be closed while the voltage <math>U_b</math> and the current <math>I_e</math> are measured and recorded. The product of the voltage <math>U_b</math> and the current <math>I_e</math> shall be integrated over the period of time, starting from the moment when the switch <math>S_1</math> is closed (<math>t_c</math>) until the voltage <math>U_b</math> falls below the high voltage threshold of 60 V DC (<math>t_h</math>). The resulting integration equals the Total Energy (TE) in Joules.</p> $TE = \int_{t_c}^{t_h} U_b \times I_e dt$ <p>When <math>U_b</math> is measured at a point in time between 10 seconds and 60 seconds after the impact and the capacitance of the X-capacitors (<math>C_x</math>) is specified by the manufacturer, Total Energy (TE) shall be calculated according to the following formula:</p> $TE = 0.5 \times C_x \times U_b^2$ |
| (b) | <p>When <math>U_1</math> and <math>U_2</math> (see Figure 1 above) are measured at a point in time between 10 seconds and 60 seconds after the impact and the capacitances of the Y-capacitors (<math>C_{y1}</math>, <math>C_{y2}</math>) are specified by the manufacturer, total energy (<math>TE_{y1}</math>, <math>TE_{y2}</math>) shall be calculated according to the following formulas:</p>   |

$$TE_{y1} = 0.5 \times C_{y1} \times U_1^2$$

$$TE_{y2} = 0.5 \times C_{y2} \times U_2^2$$

This procedure is not applicable if the test is performed under the condition where the electric power train is not energized.

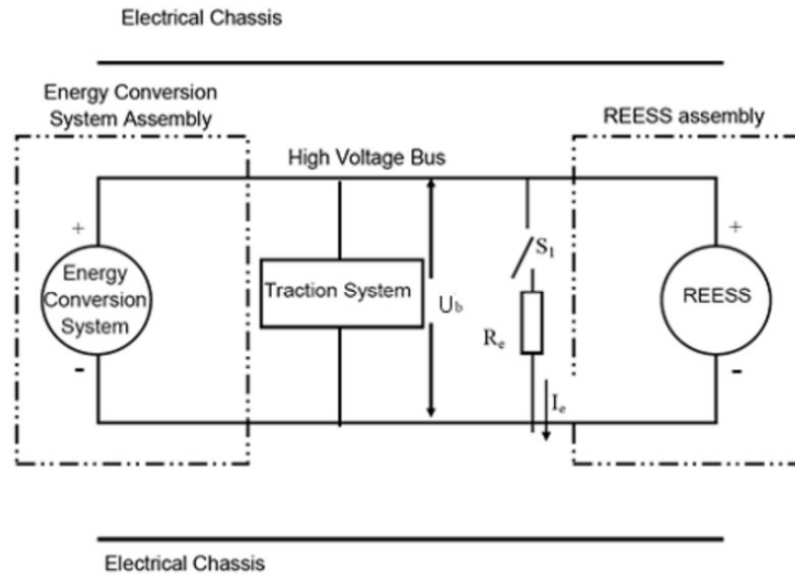

**Figure 2**  
**Measurement of high voltage bus energy stored in X-capacitors**

**4. PHYSICAL PROTECTION**

Following the vehicle impact test any parts surrounding the high voltage components shall be, without the use of tools, opened, disassembled or removed.

All remaining surrounding parts shall be considered part of the physical protection.

The jointed test finger described in Figure 3 shall be inserted into any gaps or openings of the physical protection with a test force of  $10 \text{ N} \pm 10 \text{ per cent}$  for electrical safety assessment. If partial or full penetration into the physical protection by the jointed test finger occurs, the jointed test finger shall be placed in every position as specified below.

Starting from the straight position, both joints of the test finger shall be rotated progressively through an angle of up to 90 degrees with respect to the axis of the adjoining section of the finger and shall be placed in every possible position.

Internal electrical protection barriers are considered part of the enclosure

If appropriate a low-voltage supply (of not less than 40 V and not more than 50 V) in series with a suitable lamp should be connected, between the jointed test finger and high voltage live parts inside the electrical protection barrier or enclosure.

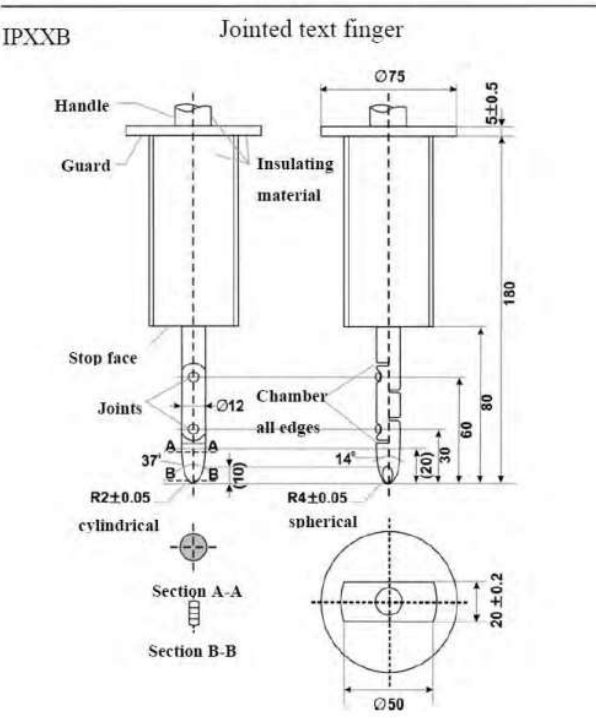
|      |   |     |                       |      |                  |
|------|---|-----|-----------------------|------|------------------|
|      | <p style="text-align: center;">Access probe<br/>(Dimensions in mm)</p>  <p style="text-align: center;"><b>Figure 3</b><br/><b>Jointed Test Finger</b></p>   |     |                       |      |                  |
|      | <p>Material: metal, except where otherwise specified<br/>         Linear dimensions in mm.<br/>         Tolerances on dimensions without specific tolerance:</p>  |     |                       |      |                  |
|      | <p>(a) on angles: +0/-10s;</p>  |     |                       |      |                  |
|      | <p>(b) on linear dimensions:</p> <table border="1" data-bbox="503 1354 1338 1503"> <tr> <td data-bbox="503 1354 625 1428">(i)</td> <td data-bbox="625 1354 1338 1428">up to 25mm: +0/-0.05;</td> </tr> <tr> <td data-bbox="503 1428 625 1503">(ii)</td> <td data-bbox="625 1428 1338 1503">over 25mm: ±0.2.</td> </tr> </table>   | (i) | up to 25mm: +0/-0.05; | (ii) | over 25mm: ±0.2. |
| (i)  | up to 25mm: +0/-0.05;   |     |                       |      |                  |
| (ii) | over 25mm: ±0.2.  |     |                       |      |                  |
|      | <p>Both joints shall permit movement in the same plane and the same direction through an angle of 90° with a 0 to +10° tolerance.</p> <p>The requirements of Paragraph 5.2.8.1.3. are met if the jointed test finger described in Figure 3, is unable to contact high voltage live parts.</p> <p>If necessary, a mirror or a fiberscope may be used in order to inspect whether the jointed test finger touches the high voltage buses.</p> <p>If this requirement is verified by a signal circuit between the jointed test finger and high voltage live parts, the lamp shall not light.</p> |     |                       |      |                  |

|       |  |     |   |      |                            |       |   |
|-------|--|-----|---|------|----------------------------|-------|---|
| 4.1   | Test method for measuring electric resistance:   |     |   |      |                            |       |   |
|       | <p>(a) Test method using a resistance tester.</p> <p>The resistance tester is connected to the measuring points (typically, electrical chassis and electro conductive enclosure/electrical protection barrier) and the resistance is measured using a resistance tester that meets the specification that follows:</p> <table border="1" data-bbox="505 457 1338 657"> <tr> <td data-bbox="505 457 581 522">(i)</td> <td data-bbox="581 457 1338 522">Resistance tester: Measurement current at least 0.2A;</td> </tr> <tr> <td data-bbox="505 522 581 588">(ii)</td> <td data-bbox="581 522 1338 588">Resolution: 0.01Ω or less;</td> </tr> <tr> <td data-bbox="505 588 581 657">(iii)</td> <td data-bbox="581 588 1338 657">The Resistance R shall be less than 0.1Ω.</td> </tr> </table> <p>(b) Test method using DC power supply, voltmeter and ammeter.</p> | (i) | Resistance tester: Measurement current at least 0.2A; | (ii) | Resolution: 0.01Ω or less; | (iii) | The Resistance R shall be less than 0.1Ω. |
| (i)   | Resistance tester: Measurement current at least 0.2A;  |     |   |      |                            |       |   |
| (ii)  | Resolution: 0.01Ω or less;   |     |   |      |                            |       |   |
| (iii) | The Resistance R shall be less than 0.1Ω.  |     |   |      |                            |       |   |
|       | <p>The DC power supply, voltmeter and ammeter are connected to the measuring points (Typically, electrical chassis and electro conductive enclosure/electrical protection barrier).</p> <p>The voltage of the DC power supply is adjusted so that the current flow becomes at least 0.2A.</p> <p>The Current "I" and the Voltage "U" are measured.</p> <p>The Resistance "R" is calculated according to the following formula:</p> $R = U / I$ <p>The Resistance R shall be less than 0.1Ω.</p>  |     |   |      |                            |       |   |
|       | <p>Note: If lead wires are used for voltage and current measurement, each lead wire shall be independently connected to the electrical protection barrier/enclosure/electrical chassis. Terminal can be common for voltage measurement and current measurement.</p>  |     |   |      |                            |       |   |

Example of the test method using DC power supply, voltmeter and ammeter is shown below.

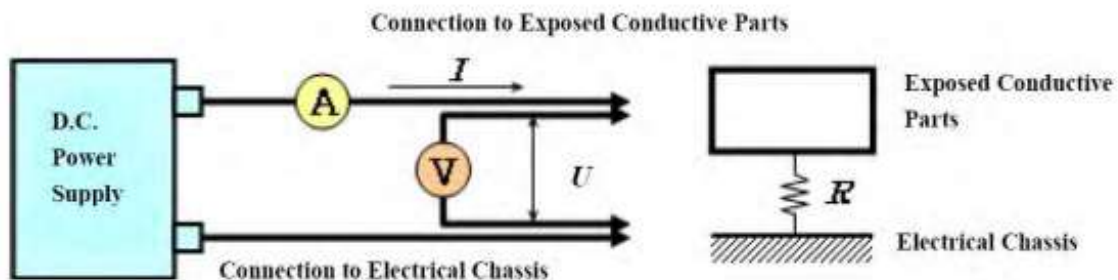

**Figure 4**  
Example of the Test Method using DC Power Supply

|         |   |
|---------|---|
| 5.      | <b>ISOLATION RESISTANCE</b>   |
| 5.1     | <p data-bbox="459 239 570 268"><b>General</b></p> <p data-bbox="459 302 1333 401">The isolation resistance for each high voltage bus of the vehicle is measured or shall be determined by calculating the measurement values of each part or component unit of a high voltage bus.</p> <p data-bbox="459 434 1333 499">All measurements for calculating voltage(s) and electrical isolation are made after a minimum of 10s after the impact</p>  |
| 5.2     | <p data-bbox="459 539 745 569"><b>Measurement Method</b></p> <p data-bbox="459 602 1333 737">The isolation resistance measurement is conducted by selecting an appropriate measurement method from among those listed in Paragraphs 5.2.1. to 5.2.2. of this Annex, depending on the electrical charge of the live parts or the isolation resistance.</p> <p data-bbox="459 770 1333 898">The range of the electrical circuit to be measured is clarified in advance, using electrical circuit diagrams. If the high voltage buses are conductively isolated from each other, isolation resistance shall be measured for each electrical circuit.</p> <p data-bbox="459 932 1333 1031">Moreover, modifications necessary for measuring the isolation resistance may be carried out, such as removal of the cover in order to reach the live parts, drawing of measurement lines and change in software.</p> <p data-bbox="459 1064 1333 1297">In cases where the measured values are not stable due to the operation of the on-board isolation resistance monitoring system, necessary modifications for conducting the measurement may be carried out by stopping the operation of the device concerned or by removing it. Furthermore, when the device is removed, a set of drawings will be used to prove that the isolation resistance between the live parts and the electrical chassis remains unchanged.</p> <p data-bbox="459 1331 1118 1360">These modifications shall not influence the test results.</p> <p data-bbox="459 1394 1333 1480">Utmost care shall be exercised to avoid short circuit and electric shock since this confirmation might require direct operations of the high-voltage circuit.</p> |
| 5.2.1   | Measurement Method using DC Voltage from External Sources   |
| 5.2.1.1 | <p data-bbox="459 1589 764 1619"><b>Measurement Instrument</b></p> <p data-bbox="459 1652 1333 1717">An isolation resistance test instrument capable of applying a DC voltage higher than the working voltage of the high voltage bus shall be used.</p>  |
| 5.2.1.2 | <p data-bbox="459 1747 727 1776"><b>Measurement Method</b></p> <p data-bbox="459 1810 1333 1938">An isolation resistance test instrument is connected between the live parts and the electrical chassis. The isolation resistance is subsequently measured by applying a DC voltage at least half of the working voltage of the high voltage bus.</p>   |

|           |  |
|-----------|--|
|           | <p>If the system has several voltage ranges (e.g. because of boost converter) in conductively connected circuit and some of the components cannot withstand the working voltage of the entire circuit, the isolation resistance between those components and the electrical chassis can be measured separately by applying at least half of their own working voltage with those components disconnected.</p>  |
| 5.2.2     | Measurement Method using the Vehicle's own REESS as DC Voltage Source  |
| 5.2.2.1   | <p>Test Vehicle Conditions</p> <p>The high voltage-bus is energized by the vehicle's own REESS and/or energy conversion system and the voltage level of the REESS and/or energy conversion system throughout the test shall be at least the nominal operating voltage as specified by the vehicle manufacturer.</p>  |
| 5.2.2.2   | <p>Measurement Instrument</p> <p>The voltmeter used in this test shall measure DC values and have an internal resistance of at least 10 MΩ.</p>  |
| 5.2.2.3   | Measurement Method   |
| 5.2.2.3.1 | <p>First Step</p> <p>The voltage is measured as shown in Figure 1 and the high voltage bus voltage (<math>U_b</math>) is recorded. <math>U_b</math> shall be equal to or greater than the nominal operating voltage of the REESS and/or energy conversion system as specified by the vehicle manufacturer.</p>   |
| 5.2.2.3.2 | <p>Second Step</p> <p>The voltage (<math>U_1</math>) between the negative side of the high voltage bus and the electrical chassis is measured and recorded (see Figure 1).</p>   |
| 5.2.2.3.3 | <p>Third Step</p> <p>The voltage (<math>U_2</math>) between the positive side of the high voltage bus and the electrical chassis is measured and recorded (see Figure 1).</p>  |
| 5.2.2.3.4 | <p>Fourth Step</p> <p>If <math>U_1</math> is greater than or equal to <math>U_2</math>, a standard known resistance (<math>R_o</math>) is inserted between the negative side of the high voltage bus and the electrical chassis. With <math>R_o</math> installed, the voltage (<math>U_1'</math>) between the negative side of the high voltage bus and the electrical chassis is measured (see Figure 5).</p> <p>The electrical isolation (<math>R_i</math>) is calculated according to the following formula:</p> $R_i = R_o \times U_b \times (1/U_1' - 1/U_1)$ |

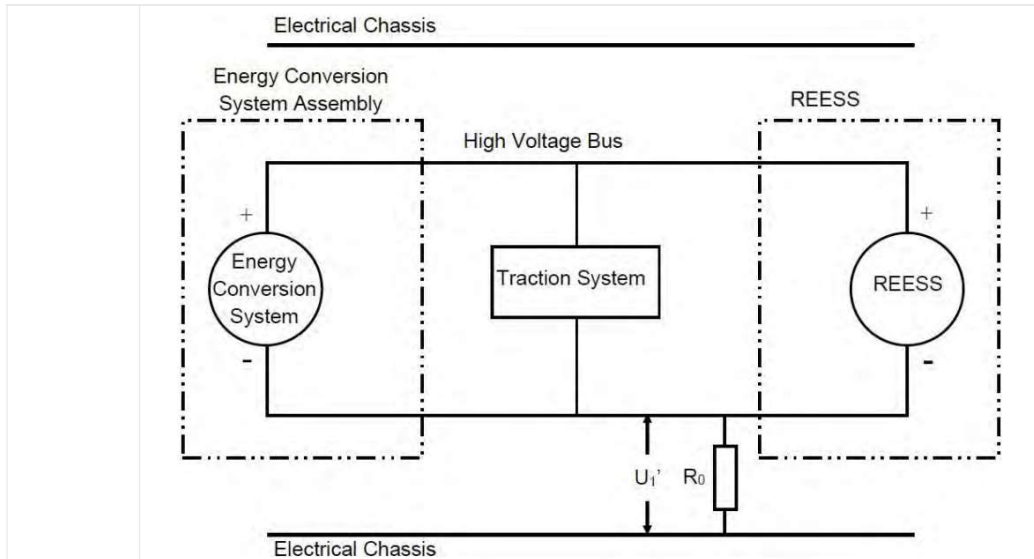

**Figure 5**  
**Measurement of  $U_1'$**

If  $U_2$  is greater than  $U_1$ , insert a standard known resistance ( $R_0$ ) between the positive side of the high voltage bus and the electrical chassis. With  $R_0$  installed, measure the voltage ( $U_2'$ ) between the positive side of the high voltage bus and the electrical chassis (see Figure 11 below). The electrical isolation ( $R_i$ ) is calculated according to the following formula.

$$R_i = R_0 \times U_b \times (1/U_2' - 1/U_2)$$

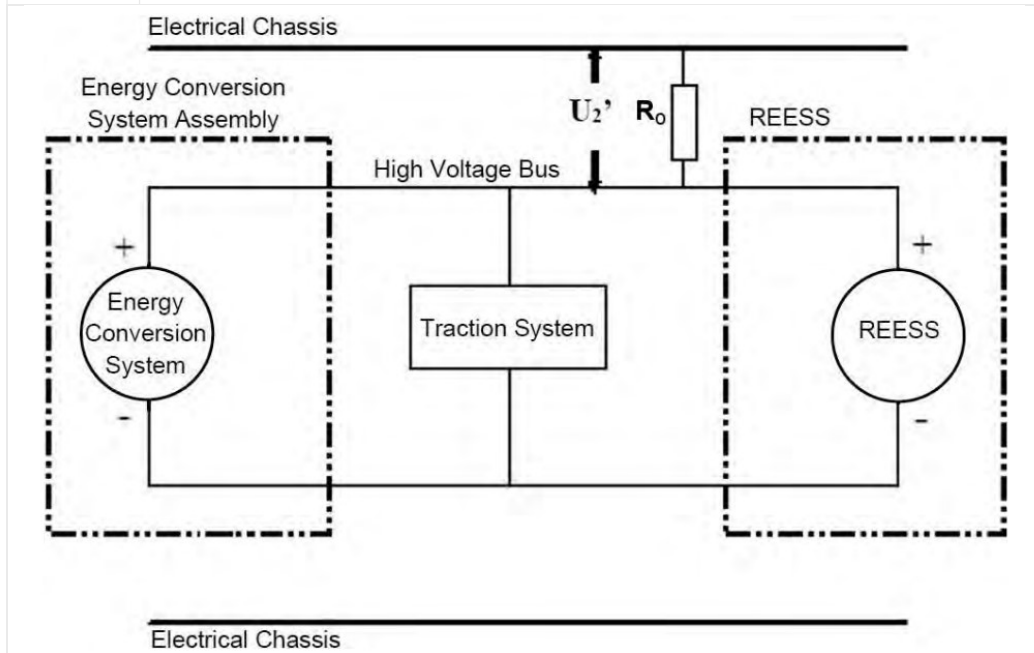

**Figure 6**  
**Measurement of  $U_2'$**

|           |   |
|-----------|---|
| 5.2.2.3.5 | <p>Fifth Step.</p> <p>The electrical isolation Value <math>R_i</math> (in <math>\Omega</math>) divided by the working voltage of the high voltage bus (in V) results in the isolation resistance (in <math>\Omega/V</math>).</p> <p>Note: The standard known resistance <math>R_o</math> (in <math>\Omega</math>) should be the value of the minimum required isolation resistance (<math>\Omega/V</math>) multiplied by the working voltage (V) of the vehicle <math>\pm 20\%</math>. <math>R_o</math> is not required to be precisely this value since the equations are valid for any <math>R_o</math>; however, a <math>R_o</math> value in this range should provide a good resolution for the voltage measurements.</p> |
| 6.        | <p><b>ELECTROLYTE LEAKAGE</b></p> <p>An appropriate coating shall be applied, if necessary, to the physical protection (casing) in order to confirm any electrolyte leakage from the REESS resulting from the test. Unless the manufacturer provides means to differentiate between the leakage of different liquids, all liquid leakage shall be considered as the electrolyte.</p>  |
| 7.        | <p><b>REESS RETENTION</b></p> <p>Compliance shall be determined by visual inspection.</p>   |

## ANNEX 7

(See Introduction)

**COMPOSITION OF AISC PANEL \*****Automotive Industry Standards Sub Committee on Frontal Collision**

| <b>Panel convener</b>             | <b>Representing</b>                            |
|-----------------------------------|--|
| Mr. C Anilkumar                   | SIAM (Tata Motors Ltd.)                        |
| <b>Members</b>                    |  |
| Mr. A. V. Mannikar                | The Automotive Research Association of India   |
| Mr. B. S. Yamgar                  | The Automotive Research Association of India   |
| Mr. Dileep Kulkarni               | The Automotive Research Association of India   |
| Mr. Vishal P. Rawal               | The Automotive Research Association of India   |
| Ms. Shubhangi Dalvi               | Central Institute of Road Transport            |
| Mr. Praveen Kumar                 | Global Automotive Research Centre              |
| Mr. Hariharan R                   | Global Automotive Research Centre              |
| Mr. Murali                        | Global Automotive Research Centre              |
| Mr. Krushna Magar                 | Global Automotive Research Centre              |
| Mr. Amit Kumar                    | International Centre for Automotive Technology |
| Ms. Vijayanta Ahuja               | International Centre for Automotive Technology |
| Mr. Ashish Kumar                  | International Centre for Automotive Technology |
| Mr. Rohit Yadav                   | International Centre for Automotive Technology |
| Mr. Ved Prakash Gautam            | SIAM (Ashok Leyland Ltd.)                      |
| Mr. Satyanarayana Gupta Bolisetty | SIAM (Bajaj Auto Ltd.)                         |
| Mr. Girish S. Kodollikar          | SIAM (Force Motors Ltd.)                       |
| Mr. S. Muthu Kumar                | SIAM (Honda Cars R&D India Ltd.)               |
| Mr. Satyanarayana                 | SIAM (Hyundai Motor India Ltd.)                |
| Mr. P S Vatsalya                  | SIAM (Hyundai Motor India Ltd.)                |
| Mr. Rahul Rijhwani                | SIAM (Isuzu Motors India)                      |
| Mr. Praveen Kumar                 | SIAM (Isuzu Motors India)                      |
| Mr. Alauddin Ali                  | SIAM (Jaguar Land Rover India Ltd.)            |
| Mr. S. Muthukumar                 | SIAM (Mahindra Truck & Bus Div.)               |
| Mr. Sudhir Sathe                  | SIAM (Mahindra & Mahindra Ltd.)                |
| Mr. Shailesh Kulkarni             | SIAM (Mahindra & Mahindra Ltd.)                |
| Mr. Thangaraj Karuppasamy         | SIAM (Mahindra & Mahindra Ltd.)                |
| Mr. Devinder Tangri               | SIAM (Mahindra & Mahindra Ltd.)                |
| Ms. Pushpanjali Pathak            | SIAM (Mahindra & Mahindra Ltd.)                |
| Mr. Dhotre Abhijit                | SIAM (Mahindra & Mahindra Ltd)                 |

|                             |  |
|-----------------------------|--|
| Mr. Venkatesh G             | SIAM (Mahindra & Mahindra Ltd)             |
| Mr. Alok Jaitley            | SIAM (Maruti Suzuki India Ltd.)            |
| Mr. Gururaj Ravi            | SIAM (Maruti Suzuki India Ltd.)            |
| Mr. Amit Singh              | SIAM (Maruti Suzuki India Ltd.)            |
| Mr. Arun Kumar              | SIAM (Maruti Suzuki India Ltd.)            |
| Mr. Sumit Kumar             | SIAM (Maruti Suzuki India Ltd.)            |
| Mr. Amit Singh              | SIAM (Maruti Suzuki India Ltd.)            |
| Mr. Tarun Nagar             | SIAM (Mercedes Benz India Pvt. Ltd.)       |
| Mr. Nikhil Desai            | SIAM (Mercedes Benz India Pvt. Ltd.)       |
| Mr. Rajendra Khile          | SIAM (Renault Nissan India Pvt. Ltd.)      |
| Mr. S. Vivekraj             | SIAM (Renault Nissan India Pvt. Ltd.)      |
| Mr. Makarand Brahme         | SIAM (Skoda Auto VW Ind. Pvt. Ltd.)        |
| Mr. Aditi Deshpande         | SIAM (Skoda Auto VW Ind. Pvt. Ltd.)        |
| Mr. Milind K. Jagtap        | SIAM (Skoda Auto VW Ind. Pvt. Ltd.)        |
| Mr. Pratyush Khare          | SIAM (Tata Motors Ltd.)                    |
| Mr. P. S. Gowrishankar      | SIAM (Tata Motors Ltd.)                    |
| Mr. Atul A. Date            | SIAM (Tata Motors Ltd.)                    |
| Mr. Vinay Maurya            | SIAM (Tata Motors Ltd.)                    |
| Ms. Namrata Deb             | SIAM (Tata Motors Ltd.)                    |
| Mr. Rahul Pathak            | SIAM (Tata Motors Ltd.)                    |
| Mr. B. Sudarshan            | SIAM (Tata Motors Ltd.)                    |
| Mr. Ganesh Gadekar          | SIAM (Tata Motors Ltd.)                    |
| Mr. Raju M                  | SIAM (Toyota Kirloskar Motor Pvt. Ltd.)    |
| Mr. Vijeth Gatty            | SIAM (Toyota Kirloskar Motor Pvt. Ltd.)    |
| Mr. Dinesh G. M             | SIAM (Toyota Kirloskar Motor Pvt. Ltd.)    |
| Mr. Pavan V                 | SIAM (Toyota Kirloskar Motor Pvt. Ltd.)    |
| Mr. Pradeep E P             | SIAM (Toyota Kirloskar Motor Pvt. Ltd.)    |
| Mr. Tarun Bhat              | SIAM (Honda Cars India Ltd.)               |
| Mr. Mandeep                 | Kia India                                  |
| Mr. Hitesh Sharma           | MG Motors                                  |
| Mr. Sanjay Tank             | ACMA                                       |
| Mr. Sivakumar Sudhachandran | ACMA (Autoliv India Pvt. Ltd.)             |
| Mr. Boobalan Natarajan      | ACMA (Autoliv India Pvt. Ltd.)             |
| Mr. Kishor Golesar          | ACMA (Nippon Audiotronix Ltd.)             |
| Mr. Deepak M. K.            | ACMA (Toyota Boshoku Auto. India (P) Ltd.) |
| Mr. Niladri Sekhar Samanta  | Stellantis Group                           |
| Mr. Santosh Bhise           | Stellantis Group                           |
| Mr. Umesh Nagraj            | Valeo India                                |

**ANNEX 8**  
(See Introduction)

**COMMITTEE COMPOSITION \***  
**Automotive Industry Standards Committee**

|                          |  |
|--------------------------|--|
| <b>Chairperson</b>       |  |
| Dr. Reji Mathai          | Director, The Automotive Research Association of India   |
| <b>Members</b>           | <b>Representing</b>  |
| Representative from      | Ministry of Road Transport and Highways  |
| Representative from      | Ministry of Heavy Industries   |
| Representative from      | Office of the Development Commissioner, MSME,<br>Ministry of Micro, Small and Medium Enterprises |
| Shri Shrikant R. Marathe | Former Chairman, AISC  |
| Head TED                 | Bureau of Indian Standards   |
| Director                 | Central Institute of Road Transport  |
| Director                 | Global Automotive Research Centre  |
| Director                 | International Centre for Automotive Technology   |
| Director                 | Indian Institute of Petroleum  |
| Director                 | National Automotive Test Tracks  |
| Director                 | Vehicles Research and Development Establishment  |
| Director                 | Indian Rubber Manufacturers Research Association   |
| Representatives from     | Society of Indian Automobile Manufacturers   |
| Representative from      | Tractor and Mechanization Association  |
| Representative from      | Automotive Components Manufacturers Association of India   |
| Representative from      | Indian Construction Equipment Manufacturers' Association   |
| <b>Member Secretary</b>  |  |
| Shri Vikram Tandon       | The Automotive Research Association of India   |

\* At the time of approval of this Automotive Industry Standard (AIS)