

**Amendment No 1 (05/2025)**  
**To**  
**AIS-195 Standard**

**SAFETY AND PROCEDURAL REQUIREMENTS FOR TYPE APPROVAL  
OF HYDROGEN POWERED VEHICLES (LIQUID / COMPRESSED  
GASEOUS HYDROGEN)**

**1.0 Contents**

Insert Annexure IX Part 1 “Alternative lateral impact test for CHSS mounted at a height of 800 mm or lower”, Annexure IX Part 2 “Alternative lateral impact test for CHSS mounted at a height above 800 mm” and Annexure X “Safety checklist and type approval requirements for hydrogen powered vehicles (Liquid / Compressed gaseous hydrogen)” after Annexure VIII and renumber other Annexures.

**2.0 Clause 3.4**

Substitute following text for existing text:

3.4 Compressed hydrogen storage system (CHSS): Means a system designed to store compressed hydrogen fuel for a hydrogen fuelled vehicle and composed of a container, container attachments (if any), and all primary closure devices required to isolate the stored hydrogen from the remainder of the fuel system and the environment.

The primary closure devices shall include the following functions, which may be combined:

- (i) TPRD;
- (ii) Check valve; and
- (iii) Shut-off valve

**3.0 Clause 3.22**

Substitute following text for existing text:

3.22 Maximum allowable working pressure (MAWP): Means the highest gauge pressure to which a container or hydrogen storage system is permitted to operate under normal operating conditions.

**4.0 Page No. 3/71**

Insert following new definitions after clause 3.30:

3.31 Container Attachments: mean non-pressure bearing parts attached to the container that provide additional support and/or protection to the

container and that may be only temporarily removed for maintenance and/or inspection only with the use of tools.

- 3.32 Enclosed or semi-enclosed spaces: Means the special volumes within the vehicle (or the vehicle outline across openings) that are external to the hydrogen system (storage system, fuel cell system, internal combustion engine (ICE) and fuel flow management system)
- 3.33 Passenger compartment: means the space for occupant accommodation, bounded by the roof, floor, side walls, doors, outside glazing, front bulkhead and rear bulkhead or rear gate.
- 3.34 Single failure: means a failure caused by a single event, including any consequential failures resulting from this failure.
- 3.35 Hydrogen fueling system or Vehicle fueling system: which includes the compressed gaseous hydrogen storage system, piping, joints, and components in which hydrogen is present

## **5.0 Clause 5.0**

Substitute following text for existing text only for 1<sup>st</sup> point:

### **5.0 Part I - Specifications of Compressed gaseous hydrogen storage system**

This Part specifies the requirements for the compressed gaseous hydrogen storage system as specified in Annexure-X

## **6.0 Clause 6.0**

Substitute following text for existing text:

### **6.0 Part II – Specifications of specific components for compressed gaseous hydrogen storage system**

This Part specifies the requirements for the compressed gaseous hydrogen storage system as specified in Annexure-X. The hydrogen storage system consists of the high-pressure storage container and primary closure devices for openings into the high pressure.

## **7.0 Clause 7.0**

Substitute following text for existing text:

### **7.0 Part III – Specifications of a vehicle fuel system incorporating the compressed gaseous hydrogen storage system**

This part specifies requirements for the vehicle fuel system, which includes the compressed gaseous hydrogen storage system, piping, joints, and components in which hydrogen is present as specified in Annexure-X. The hydrogen storage system included in the vehicle fuel system shall be tested and type approved in accordance with Part I of this Standard and produced in conformity with the approved type.

## **8.0 Clause 7.1.1**

Substitute following text for existing text:

- 7.1.1 The profile of hydrogen fuelling receptacle shall comply with IS/ISO 17268 standard.

The typical profile of H35 hydrogen receptacle is illustrated in Annexure-IB (for example only). Based on mutual agreement between Certification Agencies and OEMs/Suppliers, the fuelling receptacle shall comply with test requirements laid down in IS/ISO 17268 or EC 79/2009 or SAE J2600 / SAE J2799 standards.

## **9.0 Clause 7.1.3**

Delete Clause 7.1.3 & renumber subsequent clauses 7.1.4, 7.1.5 & 7.1.6:

## **10.0 Clause 7.2.1**

Substitute following text for existing text:

- 7.2.1 The compressed gaseous hydrogen cylinder (container) shall comply with Gas Cylinder Rule, 2016 as amended from time to time. PESO may evaluate hydrogen cylinders based on BIS standard 16735:2018 or international standards such as ISO 19881:2019, UN R 134, GTR 13, EC 79/2009 (EU 406/2010), EU 2021/535 etc.

## **11.0 Clause 7.2.3**

Substitute following text for existing text:

- 7.2.3 In case that one or more directions of the vehicle crash tests specified above are not applicable to the vehicle, the CHSS shall, instead, be subject to the relevant alternative accelerations in compliance with the acceleration corridors which are specified in Tables below in both positive and negative directions. The accelerations shall be measured at the location where the CHSS is installed. The CHSS shall be mounted and fixed on the representative part of the vehicle. The mass used shall be representative for a fully equipped and filled CHSS.

The test pulse shall be within the minimum and maximum value as specified in Tables below. A higher shock level and/or longer duration as described in the maximum value in Tables below can be applied to the CHSS if recommended by the manufacturer.

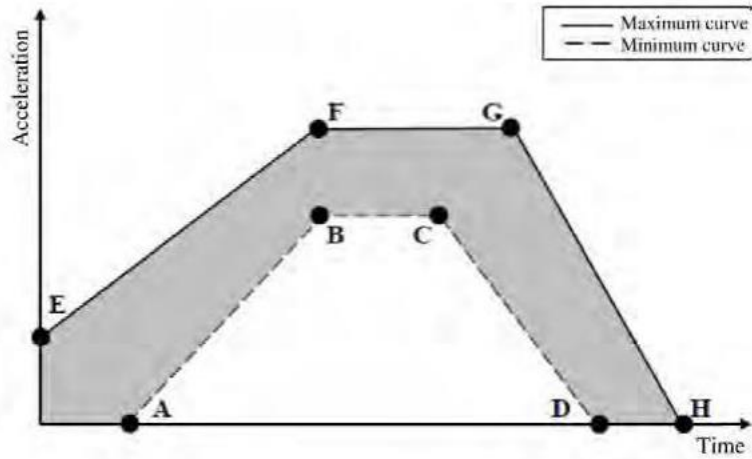

Figure: Generic Description of Test Pulses

Point	Time (ms)	For M1 and N1 vehicles		For M2 and N2 vehicles		For M3 and N3 vehicles	
		Acceleration (g)		Acceleration (g)		Acceleration (g)	
		Longitudinal	Transverse	Longitudinal	Transverse	Longitudinal	Transverse
A	20	0	0	0	0	0	0
B	50	20	8	10	5	6.6	5
C	65	20	8	10	5	6.6	5
D	100	0	0	0	0	0	0
E	0	10	4.5	5	2.5	4	2.5
F	50	28	15	17	10	12	10
G	80	28	15	17	10	12	10
H	120	0	0	0	0	0	0

A calculation method may be used instead of practical acceleration testing if its equivalence can be demonstrated by the manufacturer to the satisfaction of the Technical Service and in agreement with the Type Approval Authority.

Vehicle fuel system incorporating the hydrogen storage system shall comply with following requirements mentioned in clause 7.10.2, 7.10.3 and 7.10.4.

**12.0 Clause 7.5(b)**

Substitute following text for existing text:

- 7.5 (b) And not exceed 8 percent by volume at any time when tested according to Annexure IV, Paragraph 4.

**13.0 Clause 7.6.3**

Substitute following text for existing text:

- 7.6.3 If during operation, a single failure results in a hydrogen concentration exceeding 2.0 percent by volume in air in the enclosed or semi-enclosed spaces of the vehicle, then a warning shall be provided in accordance with 7.8. If the hydrogen concentration exceeds 3.0 percent by volume in the air in the enclosed or semi-enclosed spaces of the vehicle, the main shut-off valve shall be closed to isolate the storage system (Annexure IV, paragraph 3). Considering the overall safety hazards, the system provided by the manufacturers may trigger warning signal & shut-off valve closure at lesser hydrogen concentration percentage.

**14.0 Clause 7.7**

Substitute following text for existing text:

7.7 Fuel System Leakage

The hydrogen fuelling line (e.g. piping, joint, etc.) downstream of the main shut-off valve(s) to the fuel cell system or the engine shall not leak. Compliance shall be verified at NWP (Annex IV, Paragraph 5. test procedure). In accordance with vehicle architecture, hydrogen leakage would be tested in critical location(s) based on mutual agreement between OEMs & Certification agency.

The leak test gas shall be hydrogen, helium, or a non-reactive gas mixture containing a detectable amount of helium or hydrogen gas. Alternatively, pressure leak test requirements for piping, joints etc., may be verified as per the requirements laid down in ASME Section V article 10 T-1044.

**15.0 Clause 7.8.1(b)**

Substitute following text for existing text:

- 7.8.1 (b) Yellow or Amber in colour if the detection system malfunctions (e.g. circuit disconnection, short-circuit, sensor fault). It shall be red in compliance with section 7.6.3



Note: Above Figure is for illustration purpose only

**16.0 Clause 7.8.1(d)**

Substitute following text for existing text:

7.8.1 (d) Remains illuminated when 2.0 percent concentration or detection system malfunction exists and the ignition locking system is in the “On”(“Run”) position or the propulsion system is activated. Considering the overall safety hazards, the system provided by the manufacturers may trigger Tell-tale warning signal at lesser hydrogen concentration percentage.

**17.0 Clause 7.9**

Substitute following text for existing text:

7.9 Identification of Hydrogen Fuelled Vehicles.

In case of hydrogen vehicles of categories M1 and N1, labels shall be installed on the front and rear of the vehicle. In case of hydrogen vehicles of categories M2 and M3, labels shall be installed on the front and rear of the vehicle, and to the side of each set of service doors. In the case of hydrogen vehicles of categories N2 and N3, labels shall be installed on the front and rear of the vehicle.

**18.0 Clauses 7.2.4, 7.2.5, 7.10.1**

Delete existing clauses 7.2.4 & 7.2.5 and reserve clause 7.10.1

**19.0 Clause 7.10.3,**

Substitute following text for existing text:

7.10.3 Hydrogen gas leakage shall not result in a hydrogen concentration in the air greater than **3.0** percent by volume in the passenger and luggage compartments (Annexure IV, paragraph 2). The requirement is satisfied if it is confirmed that the shut-off valve of the storage system has closed within 5 seconds of the crash and no leakage from the storage system.

**20.0 Clause 7.10.5**

Substitute following text for existing text:

## 7.10.5 Additional Installation Requirements

### 7.10.5.1 Requirements on installation of the hydrogen storage system not subject to the frontal impact test:

The CHSS shall be mounted so that its primary closure devices (i.e., TPRD, check valve and Shut-off valve) are located in a position which is rearward of a vertical plane perpendicular to the centre line of the vehicle and located at least 420mm rearward from the front edge of the vehicle. In any case the CHSS should never be the outermost part of the vehicle.

### 7.10.5.2 Requirements on installation of the hydrogen storage system not subject to the lateral impact test:

The CHSS shall be mounted so that its primary closure devices (i.e., TPRD, Check valve and Shut-off valve) are located in a position which is between the two vertical planes parallel to the centre line of the vehicle located at least 200mm inside from the both outermost edges of the vehicle in the proximity of its container(s). In any case the CHSS should never be the outermost part of the vehicle.

### 7.10.5.3 Lateral Impact Test on Compressed Hydrogen Storage System as Alternative to 7.10.5.2

At the request of the manufacturer, the CHSS may be tested in accordance with the applicable procedure specified in either (a) or (b) below, as alternative to the requirement of Paragraph 7.10.5.2

For CHSS installed with the lowest point of any primary closure devices located at a height equal to or less than 800mm from the ground: Annex IX-Part 1

For CHSS with the lowest point of any primary closure devices located at a height 800mm above the ground: Annex IX-Part 2

After this lateral impact test, the CHSS shall comply with the requirements in 7.10.2 and 7.10.4

The CHSS to be tested will be decided by the manufacturer in agreement with the Technical Service.

A calculation method may be used instead of practical testing if its equivalence can be demonstrated by the applicant for approval to the satisfaction of the Technical Service and in agreement with the typeapproval authority.

## **21.0 Annexure IV, Clause 3.1.1.2**

Substitute following text for existing text:

- 3.1.1.2 Test gas: Two mixtures of air and hydrogen gas: 2.0% concentration (or less) of hydrogen in the air to verify function of the warning, and 3.0% concentration (or less) of hydrogen in the air to verify the shut-

down function. The proper concentrations are selected based on the recommendation (or the detector specification) by the manufacturer

**22.0 Annexure IV, Clause 3.2.1.4**

Substitute following text for existing text:

3.2.1.4 For the purpose of the test, a hydrogen concentration detector is installed where hydrogen gas may accumulate most in the passenger compartment (e.g. near the headliner) when testing for compliance with Paragraph 7.6.2 of this Standard and hydrogen concentration detector are installed in enclosed or semi enclosed volumes on the vehicle where hydrogen can accumulate from the simulated hydrogen releases when testing for compliance with Paragraph 7.6.3 of this Standard (see Annex IV, Paragraph 3.2.1.3.).

**23.0 Annexure IV, Clause 3.2.2.4**

Substitute following text for existing text:

3.2.2.4 The hydrogen concentration is measured continuously until the concentration does not rise for 3min. When testing for compliance with Paragraph 7.1.6 of this Standard, the simulated leak is then increased using the remote controllable function until the main hydrogen shut-off valve is closed and the tell-tale warning signal is activated. The monitoring of the electric power. to the shut-off valve or of the sound of the shut-off valve activation may be used to confirm the operation of the main shut-off valve of the hydrogen supply.

**24.0 Clause 3.2.2.5**

Substitute following text for existing text:

3.2.2.5 When testing for compliance with Paragraph 7.6.2 of this Standard, the test is successfully completed if the hydrogen concentration in the passenger compartment does not exceed 1.0%. When testing for compliance with Paragraph 7.6.3 of this Standard, the test is successfully completed if the tell-tale warning and shut-off function are executed at (or below) the levels specified in Paragraph 7.6.3 of this Standard; otherwise, the test is failed and the system is not qualified for vehicle service.

**25.0 Add following new Annexures Annexure IX (Part 1), (Part 2) and Annexure X after Annexure VIII**

**Annexure IX (Part 1)**

**ALTERNATIVE LATERAL IMPACT TEST FOR CHSS MOUNTED AT A HEIGHT OF 800MM OR LOWER**

**1.0 TEST CONDITIONS**

The CHSS shall be filled with hydrogen or helium to the test pressure agreed between the manufacturer together and the Technical Service. Tests shall be conducted on the CHSS in the position intended for the

installation in the vehicle including attachments, brackets and protective structures if applicable. The protective structure shall be defined by the manufacturer. At the manufacturer's discretion and in agreement with the Technical Service the CHSS may be mounted on a complete vehicle or on a representative body unit.

## 2.0 IMPACTOR

The impactor shall comply with the requirements of AIS 099 ANNEX 2(B)

## 3.0 TEST PROCEDURE

The speed of the impactor at the moment of impact shall be  $50 \pm 1$  km/h. However, if the test was performed at a higher impact speed and the compressed hydrogen storage system met the requirements, the test shall be considered satisfactory. The impact direction shall be in an angle of  $90^\circ$  to the vehicle longitudinal axis with the barrier centreline aligned with the middle transversal plane of the CHSS in the vehicle longitudinal direction.

### **Annexure IX (Part 2)**

#### **ALTERNATIVE LATERAL IMPACT TEST FOR CHSS MOUNTED AT A HEIGHT ABOVE 800MM**

## 1.0 TEST CONDITIONS

The CHSS shall be filled with hydrogen or helium to the test pressure agreed between the manufacturer together and the Technical Service. Tests shall be conducted on the CHSS in the position intended for the installation in the vehicle including attachments, brackets and protective structures if applicable. The protective structure shall be defined by the manufacturer. At the manufacturer's discretion and in agreement with the Technical Service the CHSS may be mounted on a complete vehicle or on a representative body unit.

In addition, the vehicle or body unit shall be secured in the manner prescribed for test B in Annex 1 of AIS-029.

## 2.0 IMPACTOR

The impactor shall comply with the requirements of clause numbers 7.4.1.1 and 7.4.1.2 of AIS-029.

## 3.0 TEST PROCEDURE

The impact energy shall equal be to 29.4kJ. However, if the test was performed at a higher impact energy and the CHSS met the requirements, the test shall be considered satisfactory. The impact direction shall be in an angle of  $90^\circ$  to the vehicle longitudinal with the impactor centred on the intersection line of the transversal and the

longitudinal planes passing through the middle CHSS in each direction.

### Annexure X

#### Safety checklist and type approval requirements for hydrogen powered vehicles (Liquid / Compressed gaseous hydrogen)

1	Compressed gaseous hydrogen cylinder / container	PESO, to certify or endorse in case of foreign make	Gas cylinder rules 2016 as amended from time to time or as endorsed by PESO
2	Fitment of cylinder on vehicle	Test / Certifying agency to verify as per clause 7.2 of this standard	Clause no. 7.2
3	Automatic shut-off valve	Testing of the component by authorised test / certifying agency  (PESO to certify / endorse in case component is fitted directly on cylinder)	IS/ISO 12619-6 or UN R 134 or GTR 13 or EC 79/2009 (EU 406/2010) or EU 2021/535 or ISO 19887
4	Thermally activated pressure relief device (TPRD)	Testing of the component by authorised test / certifying agency  (PESO to certify / endorse in case component is fitted directly on cylinder)	IS/ISO 12619-10 or UN R 134 or GTR 13 or EC 79/2009 (EU 406/2010) or EU 2021/535 or ISO 19887
5	Check valve	Testing of the component by authorised test	IS/ISO 12619-4 or UN R 134 or GTR 13 or EC

		/ certifying agency  (PESO to certify / endorse in case component is fitted directly on cylinder)	79/2009 (EU 406/2010) or EU 2021/535 or ISO 19887
6	Fuelling receptacle	Testing of the component by authorised test / certifying agency	IS/ISO 17268

**Note:**

Only the notified and latest version of all the standards, as mentioned in this document, shall be referred for compliance purposes based on their applicability.

Based on equivalence of test standards, certification agencies may accept compliance of other international standards as per prevailing CMVR norms/established practices.

AIS / other standards mentioned in this document to be referred till the time corresponding BIS specifications are notified under the Bureau of Indian Standard Act, 1986 (63 of 1986) and in CMVR.

Approval issued by PESO for gas cylinder & accessories fitted on it based on national and any international standards shall be acceptable for CMVR compliance purposes. The national & international standards mentioned in AIS-195 for gas cylinders and accessories are only for reference purposes and PESO may grant approval based on other international standards as well.

In line with EC 79/2009 provisions, Hydrogen fuel system components having nominal working pressure up to 30 Bar are exempted from type approval requirements.

European standards namely UN R134, GTR 13 and EU 2021/535 currently defines requirements for Gas Cylinders & accessories fitted on it. Based on emerging developments and inclusion of other H2 fuel system components, compliance of these standards can be accepted for other H2 fuel system components.

Based on the discussions between manufacturers and certification agencies, test reports / certificates issued by third party agencies from their accredited test laboratory as per prescribed national and international standards mentioned in this document may be considered and accepted for CMVR compliance purposes.

Notes mentioned above are applicable for all parts of this document wherever applicable

---

26.0 **Annexure IX, Sl. No. 3**

Substitute following text for existing text:

IS / ISO 17268 Gaseous hydrogen land vehicle refuelling connection device

27.0 **Annexure IX, Annexure X, Annexure E**

Renumber “Annexure IX, Annexure X, Annexure E” as “Annexure XI, Annexure XII, Annexure XIII”

PRINTED BY  
THE AUTOMOTIVE RESEARCH ASSOCIATION OF INDIA  
P. B. NO. 832, PUNE 411 004

ON BEHALF OF  
AUTOMOTIVE INDUSTRY STANDARDS COMMITTEE

UNDER  
CENTRAL MOTOR VEHICLES RULES - TECHNICAL STANDING COMMITTEE

SET-UP BY  
MINISTRY OF ROAD TRANSPORT & HIGHWAYS  
(DEPARTMENT OF ROAD TRANSPORT & HIGHWAYS)  
GOVERNMENT OF INDIA

7<sup>th</sup> May 2025

**AUTOMOTIVE INDUSTRY STANDARD**

**SAFETY AND PROCEDURAL  
REQUIREMENTS FOR TYPE APPROVAL  
OF HYDROGEN POWERED VEHICLES  
(LIQUID / COMPRESSED GASEOUS  
HYDROGEN)**

PRINTED BY  
THE AUTOMOTIVE RESEARCH ASSOCIATION OF INDIA  
P.B. NO. 832, PUNE 411 004

ON BEHALF OF  
AUTOMOTIVE INDUSTRY STANDARDS COMMITTEE

UNDER  
CENTRAL MOTOR VEHICLE RULES – TECHNICAL STANDING COMMITTEE

SET-UP BY  
MINISTRY OF ROAD TRANSPORT and HIGHWAYS  
(DEPARTMENT OF ROAD TRANSPORT and HIGHWAYS)  
GOVERNMENT OF INDIA

October 2023

## INTRODUCTION

The Government of India felt the need for a permanent agency to expedite the publication of standards and development of test facilities in parallel when the work on the preparation of the standards is going on, as the development of improved safety critical parts can be undertaken only after the publication of the standard and commissioning of test facilities. To this end, the erstwhile Ministry of Surface Transport (MOST) has constituted a permanent Automotive Industry Standards Committee (AISC) vide order No. RT-11028/11/97-MVL dated September 15, 1997. The standards prepared by AISC will be approved by the permanent CMVR Technical Standing Committee (CMVR-TSC). After approval, the Automotive Research Association of India, (ARAI), Pune, being the Secretariat of the AIS Committee, will publish this standard. For better dissemination of this information, ARAI may publish this document on their Web site.

Hydrogen holds promise to provide clean, reliable and sustainable energy supply for meeting the growing demand of energy in the country. Hydrogen is a fuel with the highest energy content per unit mass of all known fuels, which can be used for power generation and transportation at near zero pollution. However, developing hydrogen as an energy carrier requires solutions to many challenges in the areas of production, storage, technology development, infrastructure, energy economy and public acceptance. In order to accelerate the development and utilization of hydrogen energy in the country, a National Hydrogen Energy Board has been set up under Ministry of New and Renewable Energy, which consists of high-level representation from Government, Industry, Research institutions, Academia among others.

Among the various alternatives, hydrogen is a promising candidate, which would provide clean and efficient production of electricity and heat as well as transportation requirements. Hydrogen is poised to become a major component in the energy mix in the coming decades for meeting the growing energy needs for India's economy, while protecting the environment and ensuring energy security. It is envisaged that hydrogen will be available for a wide range of applications including power generation, portable, transport and heating applications. Hydrogen is especially suitable for meeting decentralized energy needs of the country's population.

In view of GOI's roadmap and vision and based on progressive development of Hydrogen vehicles around the globe, this AISC panel has been constituted to formulate Automotive Industry Standard for type approval of hydrogen powered vehicles (Liquid / Compressed Gaseous Hydrogen).

This standard specifies safety related performance and code of practice for hydrogen powered vehicles (Liquid / Compressed Gaseous Hydrogen). The purpose of this standard is to minimize human harm that may occur as a result of fire, burst or explosion related to the vehicle fuel system and / or from electric shock caused by the vehicle's high voltage system and also hydrogen being a Clean and Flexible Energy Source, plays a vital role to support Zero-Carbon Energy Strategies.

While formulating this standard, considerable assistance has been derived from GTR 13, ECE R 134 and EU 2021/535 Standards.

Technical specifications for the type-approval of liquefied hydrogen vehicles shall comply with test requirements laid down in (EU) 2021/535 or GTR 13

Technical specifications for the type-approval of compressed gaseous hydrogen vehicles shall comply with test requirements laid down in GTR 13 or ECE R 134 as applicable.

Since on-road vehicle experience with liquefied hydrogen storage systems is limited and constrained to demonstration fleets, safety requirements have not been comprehensively evaluated nor have test procedures been widely examined for feasibility and relevance to known failure conditions. Therefore, optional requirements and test procedures for vehicles with liquefied hydrogen storage systems are presented in Annexure VIII of this Standard, for consideration by approval authorities for possible adoption into their individual standards. It is expected that these requirements will be considered as requirements in future for vehicles with liquefied hydrogen storage systems.

Composition of the Panel and Automotive Industry Standards Committee (AISC) responsible for preparation and approval of this standard are given in Annexure X & XI respectively.

## CONTENTS

Clause No.	Details	Page No.
1.0	Scope	1/71
2.0	Reference Standards	1/71
3.0	Definitions	1/71
4.0	Schematic representation of Compressed gaseous hydrogen vehicle	3/71
5.0	Part I - Specifications of Compressed gaseous hydrogen storage system	3/71
6.0	Part II – Specifications of specific components for compressed gaseous hydrogen storage system	9/71
7.0	Part III – Specifications of a vehicle fuel system incorporating the compressed gaseous hydrogen storage system	10/71

## LIST OF ANNEXURES

Annexure-IA	Typical representation of compressed gaseous hydrogen vehicle.	17/71
Annexure-IB	Typical Profile of Hydrogen Fueling Receptacle.	18/71
Annexure-II	Test procedures for the compressed gaseous hydrogen storage system.	19/71
Annexure-III	Test procedures for specific components for the compressed gaseous hydrogen storage system.	29/71
Annexure-IV	Test procedures for a vehicle fuel system incorporating the compressed gaseous hydrogen storage system.	40/71
Annexure-V	Vehicle Identification Requirements (Compressed gaseous hydrogen).	47/71
Annexure-VI	Approval testing for compressed gaseous hydrogen storage system (CHSS) modifications.	48/71
Annexure-VII	Technical Specification of Hydrogen Powered Vehicles to Be Submitted by Vehicle Manufacturer.	50/71
Annexure-VIII	Typical Liquefied Hydrogen Storage System (LHSS).	52/71
Annexure IX	Reference Standards.	69/71
Annexure X	AISC Panel Composition.	70/71
Annexure XI	Automotive Industry Standards Committee Composition.	71/71

## Safety and Procedural Requirements for Type Approval of Hydrogen Powered Vehicles (Liquid / Compressed Gaseous Hydrogen)

### 1.0 SCOPE

This standard is applicable to both Compressed gaseous hydrogen and Liquid hydrogen powered vehicles of category M & N incorporating hydrogen components, hydrogen fuelling system, compressed gaseous hydrogen storage system and hydrogen delivery system.

### 2.0 REFERENCE STANDARDS

Considerable assistance has been taken from International and national standards in preparation of this standard. The list of reference standards is consolidated in Annexure IX.

### 3.0 DEFINITIONS

For the purpose of this standard, the following definitions shall apply:

- 3.1 **“Compressed gaseous hydrogen”** Gaseous hydrogen which has been compressed and stored for use as a vehicle fuel.
  - 3.1.1 **“Liquid hydrogen”** is the liquid state of the element hydrogen.
- 3.2 **“Hydrogen-fuelled vehicle”** means any motor vehicle that uses liquid hydrogen or compressed gaseous hydrogen as a fuel to propel the vehicle.
- 3.3 **“Fuelling receptacle”** means the equipment to which a fuelling station nozzle is attached to the vehicle and through which fuel is transferred to the vehicle. The fuelling receptacle is used as an alternative to a fueling port.
- 3.4 **“Hydrogen storage system”** means a pressurized container(s), check valve, pressure relief devices (PRDs) and shut off device that isolate the stored hydrogen from the remainder of the fuel system and the environment.
- 3.5 **“Container (for hydrogen storage)”** is the component within the hydrogen storage system that stores the primary volume of compressed hydrogen fuel.
- 3.6 **“Check valve”** is an automatic non-return valve which allows gas to flow in only one direction.
- 3.7 **“Pressure relief device (PRD)”** is a device that, when activated under specified performance conditions, is used to release hydrogen from a pressurized system and thereby prevent failure of the system.
- 3.8 **“Thermally activated pressure relief device (TPRD)”** is a non-reclosing PRD activated by temperature to open and release hydrogen gas.
- 3.9 **“Automatic cylinder valve”** automatic valve rigidly fixed to the cylinder which controls the flow of gas to the fuel system.

- 3.10 “**Shut-off valve**” is a valve between the storage container and the vehicle fuel system that can be automatically activated; this valve defaults to “closed” position when not connected to a power source.
- 3.11 “**Pressure relief valve**” is a pressure relief device that opens at a preset pressure level and can re-close.
- 3.12 “**Excess flow valve**” valve which automatically shuts off, or limits, the gasflow when the flow exceeds a set design value.
- 3.13 “**Service shut-off valve**” a manually operated shut-off valve fitted on the cylinder which can open or shut-off the hydrogen supply for maintenance, servicing or emergency requirements.
- 3.14 “**Filters**” Component that is intended to remove contaminants from the compressed gaseous hydrogen.
- 3.15 “**Fittings**” connector used in joining a pipe or tubing.
- 3.16 “**Rigid fuel line**” is rigid tube which has been designed not to flex in normal operation and through which the compressed gaseous hydrogen flows.
- 3.17 “**Flexible fuel line**” is flexible tube or hose through which compressed gaseous hydrogen flows.
- 3.18 “**Gas tight housing**” means device which vents gas leakage to outside the vehicle including the gas ventilation hose.
- 3.19 “**Pressure indicator**” means pressurized device which indicates the gas pressure.
- 3.20 “**Pressure regulator**” means device used to control the delivery pressure of gaseous fuel in vehicle fuel system.
- 3.21 “**Service Pressure or Nominal working pressure (NWP)**” means the gauge pressure that characterizes typical operation of a system. For compressed gaseous hydrogen containers, NWP is the settled pressure of compressed gas in fully fuelled container or storage system at a uniform temperature of 15°C.
- 3.22 “**Maximum Working pressure**” MAPW means the maximum pressure to which a component is designed to be subjected to and which is the basis for determining the strength of the component under consideration.
- 3.23 “**Maximum fuelling pressure (MFP)**” means the maximum pressure applied to compressed system during fuelling. The maximum fuelling pressure is 125 percent of the service or nominal working pressure.
- 3.24 “**Drive direction control unit**” means a specific device physically actuated by the driver in order to select the drive direction (forward or backward), in which the vehicle will travel if the accelerator is actuated.
- 3.25 “**IP code**” means a coding system to indicate the degrees of protection provided by an enclosure against access to hazardous parts, ingress of solid foreign objects,

ingress of water to give additional information in connection with such protection.

- 3.26 **“Protection degree”** means protection provided by a barrier / enclosure related to the contact with live parts by a test probe, such as a test finger (IPXXB) or a test wire (IPXXD).
- 3.27 **“Hydrogen component”** means the hydrogen container and all other parts of the hydrogen-powered vehicle that are in direct contact with hydrogen or which form part of a hydrogen system;
- 3.28 **“Hydrogen system”** means an assembly of hydrogen components and connecting parts fitted on hydrogen-powered vehicles, excluding the propulsion systems or auxiliary power units; ‘Hydrogen systems’ shall include;
- usage monitoring and control systems
  - vehicle interface systems
  - excess flow systems
  - overpressure protection systems
  - heat exchanger failure detection systems
- 3.29 **“Inner tank”** means the part of the hydrogen container designed to use liquid hydrogen that contains the cryogenic hydrogen.
- 3.30 **“Burst disc”** means the non-reclosing operating part of a pressure relief device which, when installed in the device, is designed to burst at a predetermined pressure to permit the discharge of compressed gaseous hydrogen.

#### 4.0 **SCHEMATIC REPRESENTATION OF COMPRESSED GASEOUS HYDROGEN VEHICLE**

The typical representation of compressed gaseous hydrogen vehicle is illustrated in Annexure-IA.

#### 5.0 **Part I - Specifications of Compressed gaseous hydrogen storage system**

This Part specifies the requirements for the compressed gaseous hydrogen storage system. The hydrogen storage system consists of the high-pressure storage container and primary closure devices for openings into the high-pressure storage container. Figure 1 shows a typical compressed gaseous hydrogen storage system consisting of a pressurized container, three closure devices and their fittings. The closure devices shall include the following functions, which may be combined:

- (a) TPRD;
- (b) Check valve that prevents reverse flow to the fill line; and
- (c) Automatic shut-off valve that can close to prevent flow from the container to the fuel cell or internal combustion engine. Any shut-off valve, and TPRD that form the primary closure of flow from the storage container shall be mounted directly on or within each container. At least one component with a check valve function shall be mounted directly on or within each container

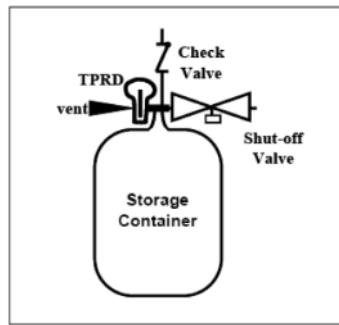

**Figure 1**

### **Typical Compressed Gaseous Hydrogen Storage System**

All new compressed gaseous hydrogen storage systems produced for on-road vehicle service shall have a NWP of 70MPa or less and a service life of 15 years (or upon the request of the manufacturer 20 years in case of vehicles of Categories M2, M3, N2 and N3 (hereinafter referred to as "20 years")) or less, and be capable of satisfying the performance requirements mentioned in this Part.

**Table 1**

#### **Overview of Performance Requirements**

- 5.1 Verification tests for baseline metrics
  - 5.1.1 Baseline initial burst pressure
  - 5.1.2 Baseline initial pressure cycle life
- 5.2 Verification test for performance durability (sequential hydraulic tests)
  - 5.2.1 Proof pressure test
  - 5.2.2 Drop (impact) test
  - 5.2.3 Surface damage
  - 5.2.4 Chemical exposure and ambient temperature pressure cycling tests
  - 5.2.5 High temperature static pressure test
  - 5.2.6 Extreme temperature pressure cycling
  - 5.2.7 Residual proof pressure test
  - 5.2.8 Residual strength Burst Test
- 5.3 Verification test for expected on-road performance (sequential pneumatic tests)
  - 5.3.1 Proof pressure test

- 5.3.2 Ambient and extreme temperature gas pressure cycling test (pneumatic)
- 5.3.3 Extreme temperature static gas pressure leak/permeation test (pneumatic)
- 5.3.4 Residual proof pressure test
- 5.3.5 Residual strength burst test (hydraulic)
- 5.4 Verification test for service terminating performance in fire

## 5.1 **Verification Tests for Baseline Metrics**

### 5.1.1 **Baseline Initial Burst Pressure**

Three (3) containers shall be hydraulically pressurized until burst (Annex II, Paragraph 2.1. test procedure). The manufacturer shall supply documentation (measurements and statistical analyses) that establish the midpoint burst pressure of new storage containers,  $BP_0$ .

All containers tested shall have a burst pressure within  $\pm 10\%$  of  $BP_0$  and greater than or equal to a minimum  $BP_{min}$  of 225% NWP.

In addition, containers having glass-fibre composite as a primary constituent to have a minimum burst pressure greater than 350% NWP.

### 5.1.2 **Baseline Initial Pressure Cycle Life**

Three (3) containers shall be hydraulically pressure cycled at the ambient temperature of  $20 (\pm 5) ^\circ\text{C}$  to 125% NWP ( $+2/-0\text{MPa}$ ) without rupture for 22,000 cycles for a 15-year service life or 30,000 cycles for a 20-year service life of vehicles of Categories M2, M3, N2 and N3 (hereinafter referred to as "a 20-year service life"), or until a leak occurs (Annex II, Paragraph 2.2. test procedure). Leakage shall not occur within 11,000 cycles for a 15-year service life or 15,000 cycles for a 20-year service life.

## 5.2 **Verification Tests for Performance Durability (Hydraulic Sequential Tests)**

If all three pressure cycle life measurements made in Paragraph 5.1.2. are greater than 11,000 cycles for a 15-year service life or 15,000 cycles for a 20-year service life, or if they are all within  $\pm 25\%$  of each other, then only one (1) container is tested in Paragraph 5.2. Otherwise, three (3) containers are tested in Paragraph 5.2.

A hydrogen storage container shall not leak during the following sequence of tests, which are applied in series to a single system and which are illustrated in Figure 2. Specifics of applicable test procedures for the hydrogen storage system are provided in Annex II, Paragraph 3.

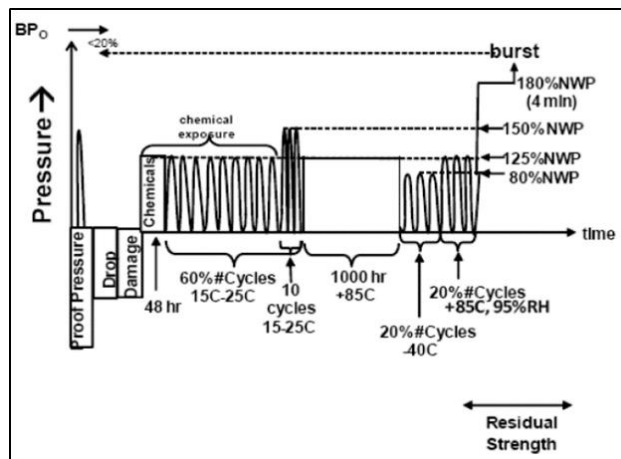

Figure 2

### Verification Test for Performance Durability (Hydraulic)

#### 5.2.1 Proof Pressure Test

A storage container is pressurized to 150% NWP (+2/-0MPa) and held for at least 30s (Annex II, Paragraph 3.1. test procedure).

#### 5.2.2 Drop (Impact) Test

The storage container is dropped at several impact angles (Annex II, Paragraph 3.2. test procedure).

#### 5.2.3 Surface Damage Test

The storage container is subjected to surface damage (Annex II, Paragraph 3.3. test procedure).

#### 5.2.4 Chemical Exposure and Ambient-temperature Pressure Cycling Test

The storage container is exposed to chemicals found in the on-road environment and pressure cycled to 125% NWP (+2/-0MPa) at 20 ( $\pm 5$ ) °C for 60% number of Cycles pressure cycles (Annex II, Paragraph 3.4. test procedure). Chemical exposure is discontinued before the last 10 cycles, which are conducted to 150% NWP (+2/-0MPa).

#### 5.2.5 High Temperature Static Pressure Test

The storage container is pressurized to 125% NWP (+2/-0MPa) at  $\geq 85^\circ\text{C}$  for at least 1,000h (Annex II, Paragraph 3.5. test procedure).

#### 5.2.6 Extreme Temperature Pressure Cycling

The storage container is pressure cycled at  $\leq -40^\circ\text{C}$  to 80% NWP (+2/-0MPa) for 20% number of Cycles and at  $\geq +85^\circ\text{C}$  and 95 ( $\pm 2$ ) % relative humidity to 125% NWP (+2/-0MPa) for 20% number of Cycles (Annex II, Paragraph 2.2. test procedure).

5.2.7 **Hydraulic residual pressure test.**

The storage container is pressurized to 180% NWP (+2/-0MPa) and held at least 4min without burst (Annex II, Paragraph 3.1. test procedure).

5.2.8 **Residual Burst Strength Test**

The storage container undergoes a hydraulic burst test to verify that the burst pressure is at least 80% of the baseline initial burst pressure (BPO) determined in Paragraph 5.1.1. (Annex II, Paragraph 2.1. test procedure).

5.3 **Verification Test for Expected On-road Performance (Pneumatic Sequential Tests)**

A hydrogen storage system shall not leak during the following sequence of tests, which are illustrated in Figure 3. Specifics of applicable test procedures for the hydrogen storage system are provided in Annex II.

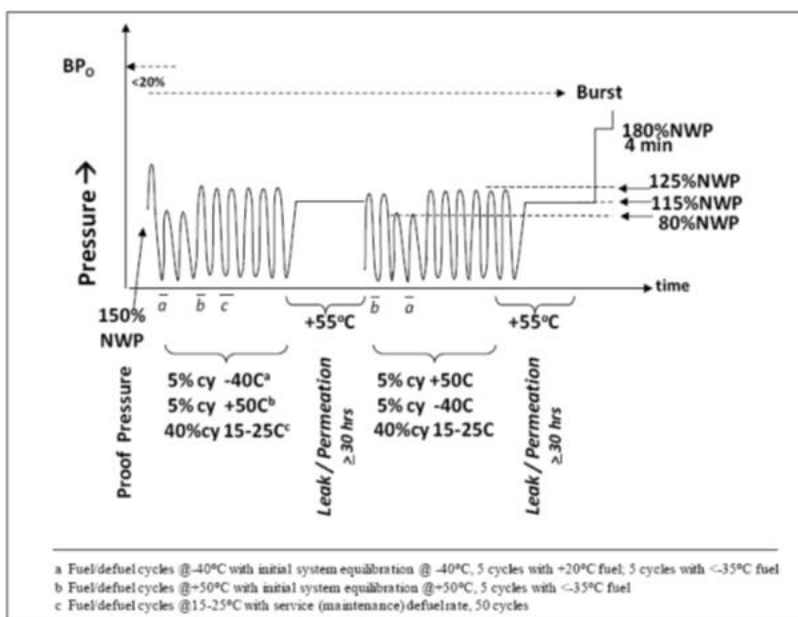

Figure 3

**Verification Test for Expected On-road Performance (Pneumatic/Hydraulic)**

5.3.1 **Proof Pressure Test**

A system is pressurized to 150% NWP (+2/-0MPa) for at least 30s (Annex II, Paragraph 3.1. test procedure). A storage container that has undergone a proof pressure test in manufacture may be exempted from this test.

5.3.2 **Ambient and Extreme Temperature Gas Pressure Cycling Test**

The system is pressure cycled using hydrogen gas for 500 cycles (Annex II, Paragraph 4.1. test procedure).

(a) The pressure cycles are divided into two groups: Half of the cycles (250)

are performed before exposure to static pressure (Paragraph 5.3.3.) and the remaining half of the cycles (250) are performed after the initial exposure to static pressure (Paragraph 5.3.3.) as illustrated in Figure 3;

- (b) The first group of pressure cycling, 25 cycles are performed to 80% NWP (+2/-0MPa) at  $\leq -40^{\circ}\text{C}$ , then 25 cycles to 125% NWP (+2/-0MPa) at  $\geq +50^{\circ}\text{C}$  and 95 ( $\pm 2$ ) % relative humidity, and the remaining 200 cycles to 125% NWP (+2/-0MPa) at  $20 (\pm 5)^{\circ}\text{C}$ ;

The second group of pressure cycling, 25 cycles are performed to 125% NWP (+2/-0MPa) at  $\geq +50^{\circ}\text{C}$  and 95 ( $\pm 2$ ) % relative humidity, then 25 cycles to 80% NWP (+2/-0MPa) at  $\leq -40^{\circ}\text{C}$ , and the remaining 200 cycles to 125% NWP (+2/-0MPa) at  $20 (\pm 5)^{\circ}\text{C}$ ;

- (c) The hydrogen gas fuel temperature is  $\leq -40^{\circ}\text{C}$ ;
- (d) During the first group of 250 pressure cycles, five cycles are performed with fuel having a temperature of  $+20 (\pm 5)^{\circ}\text{C}$  after temperature equilibration of the system at  $\leq -40^{\circ}\text{C}$ ; five cycles are performed with fuel having a temperature of  $\leq -40^{\circ}\text{C}$ ; and five cycles are performed with fuel having a temperature of  $\leq -40^{\circ}\text{C}$  after temperature equilibration of the system at  $\geq +50^{\circ}\text{C}$  and 95% relative humidity;
- (e) Fifty pressure cycles are performed using a de-fuelling rate greater than or equal to the maintenance de-fuelling rate.

### 5.3.3 **Extreme Temperature Static Pressure Leak/Permeation Test**

- (a) The test is performed after each group of 250 pneumatic pressure cycles in Paragraph 5.3.2.;
- (b) The maximum allowable hydrogen discharge from the compressed gaseous hydrogen storage system is 46ml/h/l water capacity of the storage system. (Annex II, Paragraph 4.2. test procedure);
- (c) If the measured permeation rate is greater than 0.005mg/s (3.6Nml/min), a localized leak test is performed to ensure no point of localized external leakage is greater than 0.005mg/s (3.6Nml/min) (Annex II, Paragraph 4.3. test procedure).

### 5.3.4 **Residual Proof Pressure Test (Hydraulic)**

The storage container is pressurized to 180% NWP (+2/-0MPa) and held at least 4min without burst (Annex II, Paragraph 3.1. test procedure).

### 5.3.5 **Residual Strength Burst Test (Hydraulic)**

The storage container undergoes a hydraulic burst to verify that the burst pressure is at least 80% of the baseline initial burst pressure (BPO) determined in Paragraph 5.1.1. (Annex II, Paragraph 2.1. test procedure).

## 5.4 **Verification Test for Service Terminating Performance in Fire**

This Section describes the fire test with compressed gaseous hydrogen as the

test gas. Compressed air may be used as an alternative test gas.

A hydrogen storage system is pressurized to NWP and exposed to fire (Annex II, Paragraph 5.1. test procedure). A temperature-activated pressure relief device shall release the contained gases in a controlled manner without rupture.

#### 5.5 **Requirements for Primary Closure Devices**

The primary closure devices that isolate the high-pressure hydrogen storage system, namely TPRD, check valve and shut-off valve, as described in Figure 1, shall be tested and type approved in accordance with Part II of this Standard and produced in conformity with the approved type.

Retesting of the storage system is not required if alternative closure devices are provided having comparable function, fittings, materials, strength and dimensions, and satisfy the condition above. However, a change in TPRD hardware, its position of installation or venting lines shall require a new fire test in accordance with Paragraph 5.4.

#### 5.6 **Labelling**

A label shall be permanently affixed on each container with at least the following information: name of the manufacturer, serial number, date of manufacture, MFP, NWP, type of fuel (e.g. "CHG" for gaseous hydrogen), and date of removal from service. Each container shall also be marked with the number of cycles used in the testing programme as per Paragraph 5.1.2. Any label affixed to the container in compliance with this Paragraph shall remain in place and be legible for the duration of the manufacturer's recommended service life for the container.

Date of removal from service shall not be more than 15 years (or 20 years) after the date of manufacture.

### 6.0 **Part II – Specifications of specific components for compressed gaseous hydrogen storage system**

This Part specifies the requirements for the compressed gaseous hydrogen storage system. The hydrogen storage system consists of the high-pressure storage container and primary closure devices for openings into the high pressure.

#### 6.1 **TPRD Requirements**

TPRDs shall meet the following performance requirements:

- (a) Pressure cycling test (Annex III, Paragraph 1.1.);
- (b) Accelerated life test (Annex III, Paragraph 1.2.);
- (c) Temperature cycling test (Annex III, Paragraph 1.3.);
- (d) Salt corrosion resistance test (Annex III, Paragraph 1.4.);

- (e) Vehicle environment test (Annex III, Paragraph 1.5.);
- (f) Stress corrosion cracking test (Annex III, Paragraph 1.6.);
- (g) Drop and vibration test (Annex III, Paragraph 1.7.);
- (h) Leak test (Annex III, Paragraph 1.8.);
- (i) Bench top activation test (Annex III, Paragraph 1.9.);
- (j) Flow rate test (Annex III, Paragraph 1.10.).

## 6.2 **Check Valve and Automatic Shut-off Valve Requirements**

Check valves and automatic shut-off valves shall meet the following performance requirements:

- (a) Hydrostatic strength test (Annex III, Paragraph 2.1.);
- (b) Leak test (Annex III, Paragraph 2.2.);
- (c) Extreme temperature pressure cycling test (Annex III, Paragraph 2.3.);
- (d) Salt corrosion resistance test (Annex III, Paragraph 2.4.);
- (e) Vehicle environment test (Annex III, Paragraph 2.5.);
- (f) Atmospheric exposure test (Annex III, Paragraph 2.6.);
- (g) Electrical tests (Annex III, Paragraph 2.7.);
- (h) Vibration test (Annex III, Paragraph 2.8.);
- (i) Stress corrosion cracking test (Annex III, Paragraph 2.9.);
- (j) Pre-cooled hydrogen exposure test (Annex III, Paragraph 2.10.).

6.3 At least the following information: MFP and type of fuel (e.g. "CHG" for gaseous hydrogen), shall be marked on each component having the function(s) of the primary closure devices in clearly legible and indelible manner.

## 7.0 **Part III – Specifications of a vehicle fuel system incorporating the compressed gaseous hydrogen storage system**

This part specifies requirements for the vehicle fuel system, which includes the compressed gaseous hydrogen storage system, piping, joints, and components in which hydrogen is present. The hydrogen storage system included in the vehicle fuel system shall be tested and type approved in accordance with Part I of this Standard and produced in conformity with the approved type.

### 7.1 **Requirements for hydrogen fuelling receptacle**

7.1.1 The geometry of the fuelling receptacle of compressed gaseous hydrogen gas vehicles shall conform to international standard ISO 17268:2012 (or later revisions). The typical profile of H35 hydrogen receptacle is illustrated in Annexure-IB (Example only).

- 7.1.2 The compressed gaseous hydrogen fuelling receptacle must be integrated with a non- return valve which shall prevent reverse flow to the atmosphere. Test procedure is by visual inspection.
- 7.1.3 A label shall be affixed close to the fuelling receptacle, for instance inside a refilling hatch, showing the following information: Fuel type (e.g. “CHG” for gaseous hydrogen/H<sub>2</sub> gas, Maximum fuelling pressure (MFP), Nominal working pressure (NWP), date of removal from service of containers e.g.

**H<sub>2</sub> gas**

**‘XX’ MPa**

Where ‘XX’= nominal working pressure of the container.

- 7.1.4 The fuelling receptacle shall be mounted on the vehicle to ensure positive locking of the fuelling nozzle. The receptacle shall be protected from tempering and the ingress of dirt and water (e.g. installed in a compartment which can be locked. Test procedure is by visual inspection.
- 7.1.5 The fuelling receptacle shall not be mounted within external energy absorbing elements of the vehicle (e.g. bumper) and shall be installed in such a way that access for refilling shall not be required in the passenger compartment, luggage compartment or in any other unventilated compartment. Test procedure is by visual inspection.
- 7.1.6 The compliance plate shall be installed near the filling connection and shall be clearly visible to the person filling the H<sub>2</sub> gas. The compliance plate shall contain following information:
- Fuel
  - NWP-Nominal working pressure
  - H<sub>2</sub> cylinder Identification number(s)
  - Date of installation
  - Water capacity (Liters) of the total installed
  - Date of retesting
  - Date of removal from service of containers

**7.2 Requirements for Hydrogen cylinder/container**

- 7.2.1 The compressed gaseous hydrogen cylinder (container) shall comply with Gas Cylinder Rule, 2016 as amended from time to time. PESO may evaluate hydrogen cylinders based on BIS standard or international standards such as IS 16735:2018, ISO 19881:2019, UN R 134, UN GTR 13.
- 7.2.2 The vehicle fuel system including compressed gaseous hydrogen storage system shall comply with frontal impact (AIS-096) or (AIS-098) as applicable and lateral impact (AIS-099) crash safety requirements. International standards

to be accepted as per CMVR norms.

- 7.2.3 In case that one or both of the vehicle crash tests specified above are not applicable to the vehicle, the compressed gaseous hydrogen storage system shall, instead, be subject to the relevant alternative accelerations specified below and the compressed gaseous hydrogen storage system shall comply with the relevant requirements in Paragraphs 7.2.3. and 7.2.4. The accelerations shall be measured at the location where the compressed gaseous hydrogen storage system is installed. The compressed gaseous hydrogen storage system shall be mounted and fixed on the representative part of the vehicle. The mass used shall be representative for a fully equipped and filled container or container assembly.

Vehicles of categories M1 and N1:

- (a) 20 g in the direction of travel (forward and rearward direction)
- (b) 8 g horizontally perpendicular to the direction of travel (to left and right).

Vehicles of categories M2 and N2:

- (a) 10 g in the direction of travel (forward and rearward direction)
- (b) 5 g horizontally perpendicular to the direction of travel (to left and right)

Vehicles of categories M3 and N3:

- (a) 6.6 g in the direction of travel (forward and rearward direction)
- (b) 5 g horizontally perpendicular to the direction of travel (to left and right)

- 7.2.4 In the case where hydrogen storage system is not subjected to frontal impact test, the container shall be mounted in a position which is rearward of a vertical plane perpendicular to centre line of the vehicle and located 420 mm rearward from the front edge of the vehicle.

- 7.2.5 In the case where hydrogen storage system is not subjected to lateral impact test, the container shall be mounted in a position which is between the two vertical planes parallel to the centre line of vehicle located 200 mm inside from the both outermost edge of the vehicle in the proximity of the container.

7.3 **Requirements for Pressure Relief Device (PRD / TPRD) (Annex IV, Paragraph 6. Test Procedure)**

- 7.3.1 The hydrogen gas discharge from pressure relief device shall not be directed:
- (a) Into enclosed or semi-enclosed spaces
  - (b) Into or towards the wheel housing
  - (c) towards hydrogen gas container
  - (d) Forward from the vehicle, or horizontally (parallel to road) from the back

sides of the vehicle

- 7.3.2 The outlet of the vent line of pressure relief device, if present shall be protected by a cap
- 7.3.3 Other pressure relief devices (such as a burst disc) may be used outside the hydrogen storage system. The hydrogen gas discharge from other pressure relief devices shall not be directed:
- (i) Towards exposed electrical terminals, exposed electrical switches or other ignition sources;
  - (ii) Into or towards the vehicle passenger or luggage compartments;
  - (iii) Into or towards any vehicle wheel housing;
  - (iv) Towards hydrogen gas containers.
- 7.4 **Over protection to low pressure system (Annex IV, Paragraph 6. Test Procedure)**
- The hydrogen system downstream of a pressure regulator shall be protected against overpressure due to the possible failure of the pressure regulator. The set pressure of the overpressure protection device shall be lower than or equal to the maximum allowable working pressure for the appropriate section of the hydrogen system.
- 7.5 **Vehicle exhaust system (Point of Discharge) (Annex IV, Paragraph 4. Test Procedure)**
- At the vehicle exhaust system's point of discharge, the hydrogen concentration level shall:
- (a) Not exceed 4 percent average by volume during any moving three- second time interval during normal operation including start-up and shut-down.
  - (b) And not exceed 8 percent at any time when tested according to Annexure IV, Paragraph 4.
- 7.6 **Protection against flammable conditions: Single failure conditions**
- 7.6.1 Hydrogen leakage and / or permeation from the hydrogen storage system shall not directly vent into the passenger or luggage compartments, or to any enclosed or semi-enclosed spaces within the vehicle that contains unprotected ignition source.
- 7.6.2 Any single failure downstream of the main hydrogen shut-off valve shall not result in accumulations in the levels of hydrogen concentration in the passenger compartment according to following test procedure defined in Annexure IV, paragraph 3.2.
- 7.6.3 If during operation, a single failure results in a hydrogen concentration exceeding 3.0 percent by volume in air in the enclosed or semi-enclosed spaces of the vehicle, then a warning shall be provided in accordance with 7.8. If the

hydrogen concentration exceeds 4.0 percent by volume in the air in the enclosed or semi-enclosed spaces of the vehicle, the main shut-off valve shall be closed to isolate the storage system (Annexure IV, paragraph 3).

#### 7.7 **Fuel System Leakage**

The hydrogen fuelling line (e.g. piping, joint, etc.) downstream of the main shut-off valve(s) to the fuel cell system or the engine shall not leak. Compliance shall be verified at NWP (Annex IV, Paragraph 5. test procedure).

#### 7.8 **Tell-tale signal warning to driver**

7.8.1 The warning shall be given by a visual signal or display text with the following properties:

- (a) Visible to the driver while in the driver's designated seating position with the driver's seat belt fastened.
- (b) Yellow in colour if the detection system malfunctions (e.g. circuit disconnection, short-circuit, sensor fault). It shall be red in compliance with section 7.6.3.



(c) When illuminated, shall be visible to the driver under both daylight and night time driving conditions.

(d) Remains illuminated when 3.0 percent concentration or detection system malfunction exists and the ignition locking system is in the "On" ("Run") position or the propulsion system is activated.

7.8.2 The compressed gaseous hydrogen storage system shall be provided with suitable device to indicate level and pressure of hydrogen in the system.

#### 7.9 **Identification of Hydrogen Fuelled Vehicles.**

On vehicles of the Categories M2/N2 and M3/N3, equipped with a compressed gaseous hydrogen system, labels shall be installed as specified in Annex 6. These labels shall be placed on the front of the vehicle and on the left side as well as on the right side of the vehicle; for the side in vicinity of a front door, if available. If there is no front door available, the label must be placed on the first third of the vehicle length. In addition, for vehicles of Category M2 and M3, a label shall be fixed to the rear of the vehicle.

#### 7.10 **Post-crash fuel system integrity (for vehicle fuel system)**

7.10.1 The vehicle fuel system shall comply with crash safety test requirements as specified in clause 7.2.2 of this standard.

7.10.2 **Fuel leakage limit**

The volumetric flow of hydrogen gas leakage shall not exceed an average of 118 Normal Litre per minute of time interval,  $\Delta t$ , as determined in accordance with Annexure IV, paragraph 1.1 or 1.2.

7.10.3 **Concentration limit in enclosed spaces**

Hydrogen gas leakage shall not result in a hydrogen concentration in the air greater than 4.0 percent by volume in the passenger and luggage compartments (Annexure IV, paragraph 2). The requirement is satisfied if it is confirmed that the shut-off valve of the storage system has closed within 5 seconds of the crash and no leakage from the storage system.

7.10.4 **Container Displacement**

The storage container(s) shall remain attached to the vehicle at a minimum of one attachment point.

7.10.5 **Additional Installation Requirements**

7.10.5.1 Lateral Impact Test on Compressed gaseous Hydrogen Storage System as Alternative to 7.2.5. Upon the manufacturer's request, for compressed gaseous hydrogen storage systems installed in vehicles to which lateral impact test as per AIS 099 is not applicable, the additional installation requirement under 7.2.5. does not apply if the compressed gaseous hydrogen storage system has passed the lateral impact test specified below:

7.10.5.1.1 **Test Conditions**

The compressed gaseous hydrogen storage system must be filled with hydrogen or helium. The test pressure shall be agreed by the manufacturer together with the Technical Service. Tests shall be conducted on the compressed gaseous hydrogen storage system in the position intended for the installation in the vehicle including attachments, brackets and protective structures if applicable. At the manufacturer's discretion and in agreement with the Technical Service the compressed gaseous hydrogen storage system may be fixed to a representative part of the frame or on a complete vehicle. The protective structure shall be defined by the manufacturer.

7.10.5.1.2 **Movable Deformable Barrier**

The Movable Deformable Barrier (MDB) shall comply with the requirements of AIS 099, Annex 2A.

7.10.5.1.3 **Lateral Impact on Compressed Gaseous Hydrogen Storage System**

The MDB speed at the moment of impact shall be  $50 \pm 1$  km/h. However, if the test was performed at a higher impact speed and the compressed gaseous hydrogen storage system met the requirements, the test shall be considered

satisfactory. The impact direction shall be in an angle of 90° to the longitudinal axis of the test set-up as defined in Paragraph 7.10.5.1.1. and the container shall be adjusted in a way that the middle of the front plate of the barrier matches the middle of the container in the horizontal and vertical. After this lateral impact test the compressed gaseous hydrogen storage system shall comply with the requirements in 7.10.2. and 7.10.4.

7.10.5.1.4 A calculation method may be used instead of practical testing if its equivalence can be demonstrated by the applicant for approval to the satisfaction of the test agency.

7.10.5.2 Requirements laid down in Paragraph 7.10.5.1 are deemed to be met in case vehicle is equipped with lateral under run protection device approved as per IS 14682: 2004 amended from time to time.

#### 7.11 **Electromagnetic Compatibility**

All electric assemblies on Hydrogen powered vehicles, which could affect safe operation of the vehicle, shall be functionally tolerant of the electromagnetic environment to which the vehicle normally will be exposed. This includes fluctuating voltage and load conditions, and electrical transients. The Hydrogen powered vehicles shall be tested according to the AIS-004 (Part 3).

#### 7.12 **Fire Prevention in Hydrogen powered vehicles**

Considering the various chemical properties of hydrogen, it is suggested that fire in hydrogen powered vehicles can be best prevented by design, construction, manufacturing, detection control system and suitable training of personnel in service. Accordingly, fitment of FDSS (Fire Detection and Suppression System) & FPS (Fire protection system) in these vehicles shall be optional.

#### 7.13 **Approval**

- a) The corrigendum, amendment and revision of standards referred in this document to be governed by AIS-000.
- b) International standards mentioned in this Standard shall be accepted for compliance as per CMVR norms.
- c) AIS / other standards mentioned in this document to be referred till the time corresponding BIS specifications are notified under the Bureau of Indian Standard Act, 1986 (63 of 1986).

## ANNEXURE-IA

Typical representation of compressed gaseous hydrogen vehicle (For Illustration Purpose only)

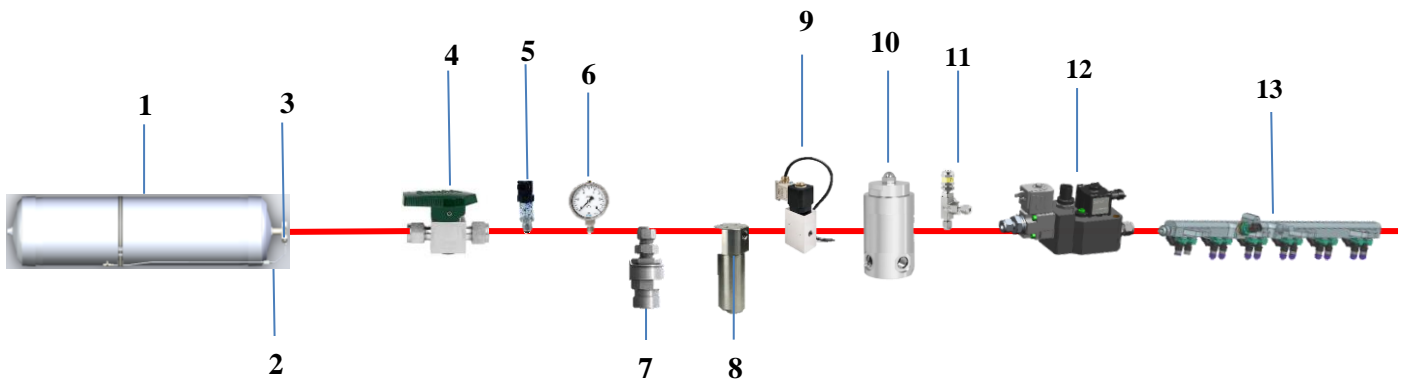

1. Tank\*
2. PRD vent\*
3. Cylinder valve\*
4. Shut off valve\*
5. Pressure transducer
6. Pressure gauge
7. Receptacle
8. Filter
9. Solenoid valve
10. HP regulator
11. PRV vent
12. LP regulator
13. Injector rail assembly

\* **Mandatory**

ANNEXURE-IB

Typical Profile of Hydrogen Fuelling Receptacle

H35 Hydrogen Receptacle (For Illustration Purpose only)

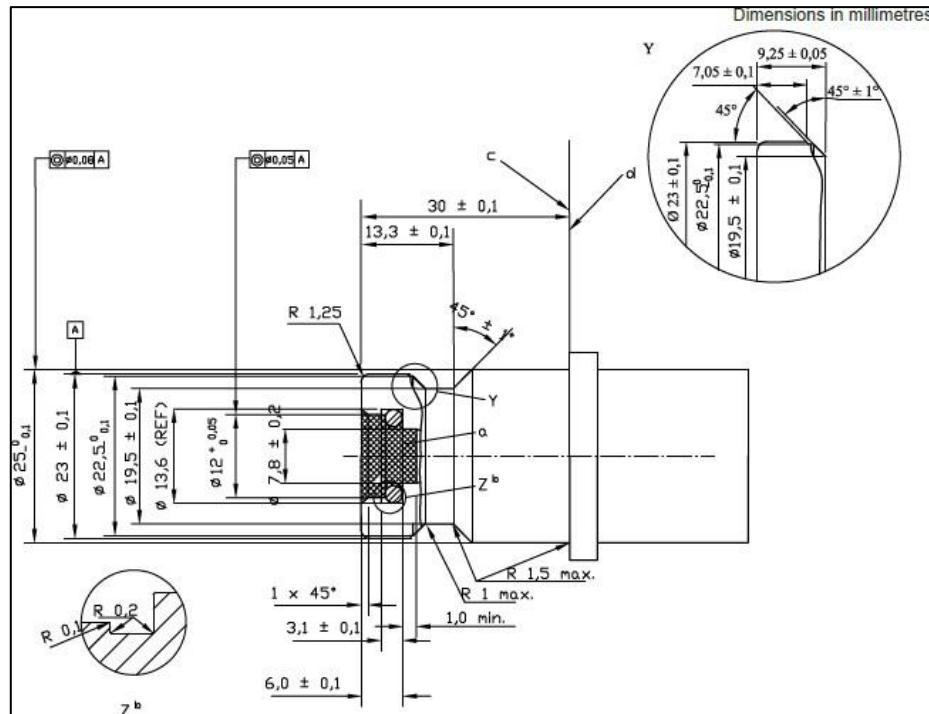

Material shall demonstrate hydrogen compatibility as described in clause 4.5 of ISO 17268 and a minimum hardness of 80 Rockwell B (HRB). Unless otherwise specified, surface finish shall be 0.4  $\mu\text{m}$  to 3.2  $\mu\text{m}$ .

- a) Shaded area represents an area, which shall be kept free of all components except for the seal. Surface finish shall be 0.8  $\mu\text{m} \pm 0.05 \mu\text{m}$ .
- b) Reference sealing material surface to a no. 110 O-Ring with the following dimensions: internal diameter: 9.19 mm  $\pm 0.13$  mm; width: 2.62 mm  $\pm 0.08$  mm.
- c) Nozzle side: No part of the nozzle assembly shall extend beyond the receptacle stop ring.
- d) Vehicle side: The stop ring shall have a continuous shape that has an effective diameter of 30 mm or more and a thickness greater than 5 mm

## ANNEXURE II

### Test procedures for the compressed gaseous hydrogen storage system

#### 1.0 Test procedures for qualification requirements of compressed gaseous hydrogen storage are organized as follows:

Paragraph 2 of this Annex is the test procedures for baseline performance metrics (requirement of Paragraph 5.1. of this Standard);

Paragraph 3 of this Annex is the test procedures for performance durability (requirement of Paragraph 5.2. of this Standard);

Paragraph 4 of this Annex is the test procedures for expected on-road performance (requirement of Paragraph 5.3. of this Standard);

Paragraph 5 of this Annex is the test procedures for service terminating performance in fire (requirement of Paragraph 5.4. of this Standard);

Paragraph 6 of this Annex is the test procedures for performance durability of primary closures (requirement of Paragraph 5.5. of this Standard).

#### 2.0 TEST PROCEDURES FOR BASELINE PERFORMANCE METRICS (Requirement of Paragraph 5.1. of this Standard)

##### 2.1 Burst Test (Hydraulic)

The burst test is conducted at the ambient temperature of 20 ( $\pm 5$ )°C using a non-corrosive fluid.

##### 2.2 Pressure Cycling Test (Hydraulic)

The test is performed in accordance with the following procedure:

- (a) The container is filled with a non-corrosive fluid;
- (b) The container and fluid are stabilized at the specified temperature and relative humidity at the start of testing; the environment, fuelling fluid and container skin are maintained at the specified temperature for the duration of the testing. The container temperature may vary from the environmental temperature during testing;
- (c) The container is pressure cycled between 2 ( $\pm 1$ ) MPa and the target pressure at a rate not exceeding 10 cycles per minute for the specified number of cycles;
- (d) The temperature of the hydraulic fluid within the container is maintained and monitored at the specified temperature.

#### 3.0 TEST PROCEDURES FOR PERFORMANCE DURABILITY (Requirement of Paragraph 5.2. of this Standard)

### 3.1 Proof Pressure Test

The system is pressurized smoothly and continually with a non-corrosive hydraulic fluid until the target test pressure level is reached and then held for the specified time.

### 3.2 Drop (Impact) Test (Unpressurized)

The storage container is drop tested at ambient temperature without internal pressurization or attached valves. The surface onto which the containers are dropped shall be a smooth, horizontal concrete pad or other flooring type with equivalent hardness.

The orientation of the container being dropped (in accordance with the requirement of Paragraph 5.2.2.) is determined as follows: One or more additional container(s) shall be dropped in each of the orientations described below. The drop orientations may be executed with a single container or as many as four containers may be used to accomplish the four drop orientations

- (i) Dropped once from a horizontal position with the bottom 1.8m above the surface onto which it is dropped;
- (ii) Dropped once onto the end of the container from a vertical position with the ported end upward with a potential energy of not less than 488J, with the height of the lower end no greater than 1.8m;
- (iii) Dropped once onto the end of the container from a vertical position with the ported end downward with a potential energy of not less than 488J, with the height of the lower end no greater than 1.8m. If the container is symmetrical (identical ported ends), this drop orientation is not required;
- (iv) Dropped once at a 45° angle from the vertical orientation with a ported end downward with its centre of gravity 1.8m above the ground. However, if the bottom is closer to the ground than 0.6m, the drop angle shall be changed to maintain a minimum height of 0.6m and a centre of gravity of 1.8m above the ground.

The four drop orientations are illustrated in Figure 1

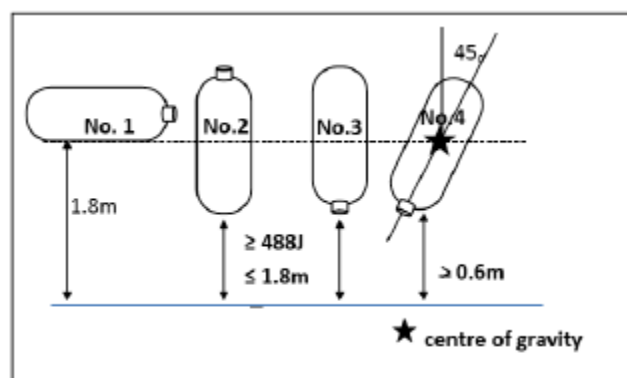

**Figure 1**

### **Drop Orientations**

No attempt shall be made to prevent the bouncing of containers, but the containers may be prevented from falling over during the vertical drop tests described above.

If more than one container is used to execute all drop specifications, then those containers shall undergo pressure cycling according to Annex 3, Paragraph 2.2. until either leakage or 22,000 cycles for a 15-year service life or 30,000 cycles for a 20-year service life without leakage have occurred. Leakage shall not occur within 11,000 cycles or a 15-year service life or 15,000 cycles for a 20-year service life.

The orientation of the container being dropped in accordance with the requirement of Paragraph 5.2.2. shall be identified as follows:

- (a) If a single container was subjected to all four drop orientations, then the container being dropped in accordance with the requirement of Paragraph 5.2.2. shall be dropped in all four orientations;
- (b) If more than one container is used to execute the four drop orientations, and if all containers reach 22,000 cycles for a 15-year service life or 30,000 cycles for a 20-year service life without leakage, then the orientation of the container being dropped in accordance with the requirement Paragraph 5.2.2. is the 45° orientation (iv), and that container shall then undergo further testing as specified in Paragraph 5.2.;
- (c) If more than one container is used to execute the four drop orientations and if any container does not reach 22,000 cycles for a 15-year service life or 30,000 cycles for a 20-year service life without leakage, then the new container shall be subjected to the drop orientation(s) that resulted in the lowest number of cycles to leakage and then will undergo further testing as specified in Paragraph 5.2.

### 3.3 **Surface Damage Test (Unpressurized)**

The test proceeds in the following sequence:

- (a) Surface flaw generation: Two longitudinal saw cuts are made on the bottom outer surface of the unpressurized horizontal storage container along the cylindrical zone close to but not in the shoulder area. The first cut is at least 1.25mm deep and 25mm long toward the valve end of the container. The second cut is at least 0.75mm deep and 200mm long toward the end of the container opposite the valve;
- (b) Pendulum impacts: The upper section of the horizontal storage container is divided into five distinct (not overlapping) areas 100mm in diameter each (see Figure 2). After 12h preconditioning at  $\leq -40^{\circ}\text{C}$  in an environmental chamber, the centre of each of the five areas sustains the impact of a pendulum having a pyramid with equilateral faces and square base, the summit and edges being rounded to a radius of 3mm. The centre of impact of the pendulum coincides with the centre of gravity of the pyramid. The energy of the pendulum at the moment of impact with each of the five marked areas on the container is 30J. The container is secured in place during pendulum impacts and not under pressure.

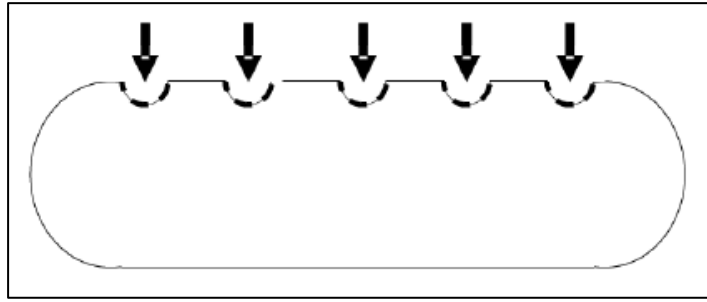

**Figure 2**  
**"Side" View of Container**

### 3.4 **Chemical Exposure and Ambient-Temperature Pressure Cycling Test**

Each of the 5 areas of the unpressurized container preconditioned by pendulum impact (Annex 3, Paragraph 3.3.) is exposed to one of five solutions:

- (a) 19% (by volume) sulphuric acid in water (battery acid);
- (b) 25% (by weight) sodium hydroxide in water;
- (c) 5% (by volume) methanol in gasoline (fluids in fuelling stations);
- (d) 28% (by weight) ammonium nitrate in water (urea solution); and
- (e) 50% (by volume) methyl alcohol in water (windshield washer fluid)

The test container is oriented with the fluid exposure areas on top. A pad of glass wool approximately 0.5 mm thick and 100 mm in diameter is placed on each of the five preconditioned areas. A sufficient amount of the test fluid is applied to the glass wool sufficient to ensure that the pad is wetted across its surface and through its thickness for the duration of the test.

The exposure of the container with the glass wool is maintained for 48h with the container held at 125% NWP (+2/-0MPa) (applied hydraulically) and 20 (±5) °C before the container is subjected to further testing.

Pressure cycling is performed to the specified target pressures according to Paragraph 2.2. of this Annex at 20 (±5) °C for the specified numbers of cycles. The glass wool pads are removed and the container surface is rinsed with water the final 10 cycles to specified final target pressure are conducted.

### 3.5 **Static Pressure Test (Hydraulic)**

The storage system is pressurized to the target pressure in a temperature-controlled chamber. The temperature of the chamber and the non-corrosive fuelling fluid is held at the target temperature within ±5°C for the specified duration.

## 4.0 **TEST PROCEDURES FOR EXPECTED ON-ROAD PERFORMANCE** **(Paragraph 5.3. of this Standard)**

(Pneumatic test procedures are provided; hydraulic test elements are described in Annex 3, Paragraph 2.1.)

#### 4.1 **Gas Pressure Cycling Test (Pneumatic)**

At the onset of testing, the storage system is stabilized at the specified temperature, relative humidity and fuel level for at least 24h. The specified temperature and relative humidity are maintained within the test environment throughout the remainder of the test. (When required in the test specification, the system temperature is stabilized at the external environmental temperature between pressure cycles.) The storage system is pressure cycled between less than 2 (+0/-1) MPa and the specified maximum pressure ( $\pm 1$ MPa). If system controls that are active in vehicle service prevent the pressure from dropping below a specified pressure, the test cycles shall not go below that specified pressure. The fill rate is controlled to a constant 3min pressure ramp rate, but with the fuel flow not to exceed 60g/s; the temperature of the hydrogen fuel dispensed to the container is controlled to the specified temperature. However, the pressure ramp rate should be decreased if the gas temperature in the container exceeds +85°C. The de-fuelling rate is controlled to greater than or equal to the intended vehicle's maximum fuel-demand rate. The specified number of pressure cycles is conducted. If devices and/or controls are used in the intended vehicle application to prevent an extreme internal temperature, the test may be conducted with these devices and/or controls (or equivalent measures).

#### 4.2 **Gas Permeation Test (Pneumatic)**

A storage system is fully filled with hydrogen gas at 115% NWP (+2/-0MPa) (full fill density equivalent to 100% NWP at +15°C is 113% NWP at +55°C) and held at  $\geq +55^\circ\text{C}$  in a sealed container until steady-state permeation or 30h, whichever is longer. The total steady-state discharge rate due to leakage and permeation from the storage system is measured.

#### 4.3 **Localized Gas Leak Test (Pneumatic)**

A bubble test may be used to fulfil this requirement. The following procedure is used when conducting the bubble test:

- (a) The exhaust of the shut-off valve (and other internal connections to hydrogen systems) shall be capped for this test (as the test is focused on external leakage).

At the discretion of the tester, the test article may be immersed in the leak-test fluid or leak-test fluid applied to the test article when resting in open air. Bubbles can vary greatly in size, depending on conditions. The tester estimates the gas leakage based on the size and rate of bubble formation.

- (b) Note: For a localized rate of 0.005mg/s (3.6Nml/min), the resultant allowable rate of bubble generation is about 2,030 bubbles per minute for a typical bubble size of 1.5mm in diameter. Even if much larger bubbles are formed, the leak should be readily detectable. For an unusually large bubble size of 6mm in diameter, the allowable bubble rate would be approximately 32 bubbles per minute.

## 5.0 TEST PROCEDURES FOR SERVICE TERMINATING PERFORMANCE IN FIRE (Paragraph 5.4. of this Standard)

### 5.1 Fire Test

The hydrogen container assembly consists of the compressed gaseous hydrogen storage system with additional relevant features, including the venting system (such as the vent line and vent line covering) and any shielding affixed directly to the container (such as thermal wraps of the container(s) and/or coverings/barriers over the TPRD(s)).

Either one of the following two methods are used to identify the position of the system over the initial (localized) fire source:

#### (a) Method 1: Qualification for a generic (non-Specific) vehicle installation

If a vehicle installation configuration is not specified (and the type approval of the system is not limited to a specific vehicle installation configuration) then the localized fire exposure area is the area on the test article farthest from the TPRD(s). The test article, as specified above, only includes thermal shielding or other mitigation devices affixed directly to the container that are used in all vehicle applications. Venting system(s) (such as the vent line and vent line covering) and/or coverings/barriers over the TPRD(s) are included in the container assembly if they are anticipated for use in any application. If a system is tested without representative components, retesting of that system is required if a vehicle application specifies the use of these type of components.

#### (b) Method 2: Qualification for a specific vehicle installation

If a specific vehicle installation configuration is specified and the type approval of the system is limited to that specific vehicle installation configuration, then the test setup may also include other vehicle components in addition to the hydrogen storage system. These vehicle components (such as shielding or barriers, which are permanently attached to the vehicle's structure by means of welding or bolts and not affixed to the storage system) shall be included in the test setup in the vehicle-installed configuration relative to the hydrogen storage system. This localized fire test is conducted on the worst-case localized fire exposure areas based on the four fire orientations: fires originating from the direction of the passenger compartment, luggage compartment, wheel wells or ground-pooled gasoline.

5.1.1 The container may be subjected to engulfing fire without any shielding components, as described in Annex 3, Paragraph 5.2.

5.1.2 The following test requirements apply whether Method 1 or 2 (above) is used:

(a) The container assembly is filled with compressed gaseous hydrogen at 100% of NWP (+2/-0MPa). The container assembly is positioned horizontally approximately 100mm above the fire source;

(b) Localized portion of the fire test:

- (i) The localized fire exposure area is located on the test article furthest from the TPRD(s). If Method 2 is selected and more vulnerable areas are identified for a specific vehicle installation configuration, the more vulnerable area that is furthest from the TPRD(s) is positioned directly over the initial fire source;
- (ii) The fire source consists of LPG burners configured to produce a uniform minimum temperature on the test article measured with a minimum 5 thermocouples covering the length of the test article up to 1.65 m maximum (at least 2 thermocouples within the localized fire exposure area, and at least 3 thermocouples equally spaced and no more than 0.5m apart in the remaining area) located 25 ( $\pm 10$ ) mm from the outside surface of the test article along its longitudinal axis. At the option of the manufacturer or testing facility, additional thermocouples may be located at TPRD sensing points or any other locations for optional diagnostic purposes;
- (iii) Wind shields are applied to ensure uniform heating;
- (iv) The fire source initiates within a 250 ( $\pm 50$ ) mm longitudinal expanse positioned under the localized fire exposure area of the test article. The width of the fire source encompasses the entire diameter (width) of the storage system. If Method 2 is selected, the length and width shall be reduced, if necessary, to account for vehicle-specific features;
- (v) As shown in Figure 3 the temperature of the thermocouples in the localized fire exposure area has increased continuously to at least 300°C within 1min of ignition, to at least 600°C within 3min of ignition, and a temperature of at least 600°C is maintained for the next 7min. The temperature in the localized fire exposure area shall not exceed 900°C during this period. Compliance to the thermal requirements begins 1min after entering the period with minimum and maximum limits and is based on a 1min rolling average of each thermocouple in the region of interest. (Note: The temperature outside the region of the initial fire source is not specified during these initial 10min from the time of ignition.).

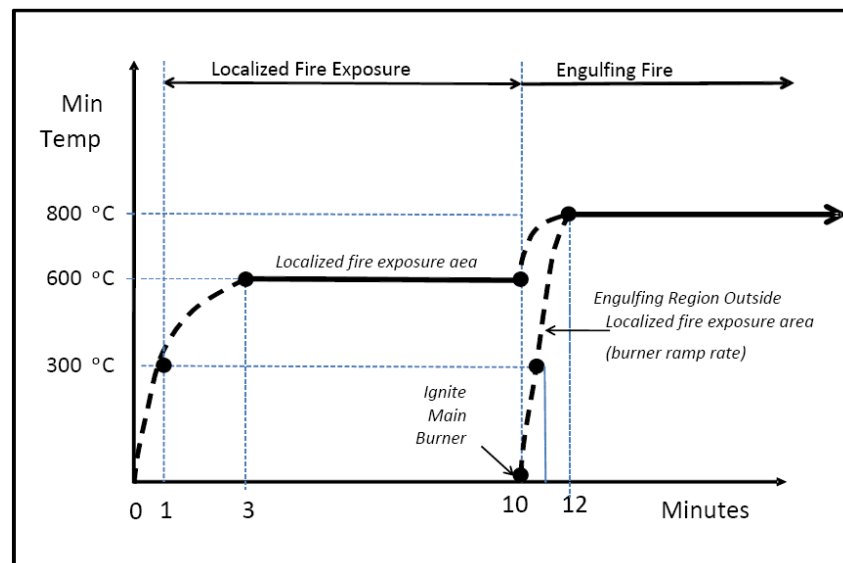

**Figure 3**  
**Temperature Profile of Fire Test**

## (c) Engulfing portion of the fire test;

Within the next 2min interval, the temperature along the entire surface of the test article shall be increased to at least 800°C and the fire source is extended to produce a uniform temperature along the entire length up to 1.65 m and the entire width of the test article (engulfing fire). The minimum temperature is held at 800°C, and the maximum temperature shall not exceed 1,100°C. Compliance to thermal requirements begins 1 min after entering the period with constant minimum and maximum limits and is based on a 1min rolling average of each thermocouple.

The test article is held at temperature (engulfing fire condition) until the system vents through the TPRD and the pressure falls to less than 1MPa. The venting shall be continuous (without interruption), and the storage system shall not rupture. An additional release through leakage (not including release through the TPRD) that results in a flame with length greater than 0.5m beyond the perimeter of the applied flame shall not occur.

## (d) Documenting results of the fire test;

The arrangement of the fire is recorded in sufficient detail to ensure the rate of heat input to the test article is reproducible. The results include the elapsed time from ignition of the fire to the start of venting through the TPRD(s), and the maximum pressure and time of evacuation until a pressure of less than 1MPa is reached. Thermocouple temperatures and container pressure are recorded at intervals of every 10 s or less during the test. Any failure to maintain specified minimum temperature requirements based on the 1min rolling averages invalidates the test result. Any failure to maintain specified maximum temperature requirements based on the 1 min rolling averages invalidates the test result only if the test article failed during the test.

## 5.2 Engulfing Fire Test

The test unit is the compressed gaseous hydrogen storage system. The storage system is filled with compressed gaseous hydrogen gas at 100% NWP (+2/-0 MPa). The container is positioned horizontally with the container bottom approximately 100 mm above the fire source. Metallic shielding is used to prevent direct flame impingement on container valves, fittings, and/or pressure relief devices. The metallic shielding is not in direct contact with the specified fire protection system (pressure relief devices or container valve).

A uniform fire source of 1.65 m length provides direct flame impingement on the container surface across its entire diameter. The test shall continue until the container fully vents (until the container pressure falls below 0.7 MPa). Any failure or inconsistency of the fire source during a test shall invalidate the result.

Flame temperatures shall be monitored by at least three thermocouples suspended in the flame approximately 25 mm below the bottom of the container. Thermocouples may be attached to steel cubes up to 25 mm on a side. Thermocouple temperature and the container pressure shall be recorded every 30s during the test.

Within five minutes after the fire is ignited, an average flame temperature of not

less than 590°C (as determined by the average of the 2 thermocouples recording the highest temperatures over a 60s interval) is attained and maintained for the duration of the test.

If the container is less than 1.65 m in length, the centre of the container shall be positioned over the centre of the fire source. If the container is greater than 1.65m in length, then if the container is fitted with a pressure relief device at one end, the fire source shall commence at the opposite end of the container. If the container is greater than 1.65m in length and is fitted with pressure relief devices at both ends, or at more than one location along the length of the container, the centre of the fire source shall be centred midway between the pressure relief devices that are separated by the greatest horizontal distance.

The container shall vent through a pressure relief device without bursting.

**Table 1**  
**Summary of Fire Test Protocol**

	Localized Fire Exposure	Time Period	Engulfing Fire Region (Outside the Localized Fire Region)
Action	Ignite Burners	0-1min	No Burner Operation
Minimum temperature	Not specified		Not specified
Maximum temperature	Less than 900°C		Not specified
Action	Increase temperature and stabilize fire for start of localized fire exposure	1-3min	No Burner Operation
Minimum temperature	Greater than 300°C		Not specified
Maximum temperature	Less than 900°C		Not specified
Action	Localized fire exposure continues		No Burner Operation
Minimum temperature	1min rolling average greater than 600°C		Not specified
Maximum temperature	1min rolling average greater than 900°C	3-10min	Not specified
Action	Increase temperature		Main Burner Ignited at 10min
Minimum temperature	1min rolling average greater than 600°C		Not specified
Maximum temperature	1min rolling average less than 1,100°C	10-11min	Less than 1,100°C
Action	Increase temperature and stabilize fire for start of engulfing fire exposure		Increase temperature and stabilize fire for start of engulfing fire exposure
Minimum temperature	1min rolling average greater than 600°C		Greater than 300°C
Maximum temperature	1min rolling average less than 1,100°C	11-12min	Less than 1,100°C
Action	Engulfing fire exposure continues		Engulfing fire exposure continues
Minimum temperature	1min rolling average greater than 800°C		1min rolling average greater than 800°C
Maximum temperature	1min rolling average less than 1,100°C	12min – end of test	1min rolling average less than 1,100°C

## ANNEXURE III

### Test procedures for specific components for the compressed gaseous hydrogen storage system

#### 1.0 TPRD QUALIFICATION PERFORMANCE TESTS

Testing is performed with hydrogen gas having gas quality compliant with ISO 14687-2/SAE J2719. All tests are performed at ambient temperature  $20 (\pm 5) ^\circ\text{C}$  unless otherwise specified. The TPRD qualification performance tests are specified as follows (see also Appendix 1):

##### 1.1 Pressure Cycling Test

Five TPRD units undergo 11,000 internal pressure cycles for a 15-year service life or 15,000 internal pressure cycles for a 20-year service life with hydrogen gas having gas quality compliant with ISO 14687-2/SAE J2719. The first five pressure cycles are between  $2 (\pm 1) \text{ MPa}$  and 150% NWP ( $\pm 1 \text{ MPa}$ ); the remaining cycles are between  $2 (\pm 1) \text{ MPa}$  and 125% NWP ( $\pm 1 \text{ MPa}$ ). The first 1,500 pressure cycles are conducted at a TPRD temperature of  $85^\circ\text{C}$  or higher. The remaining cycles are conducted at a TPRD temperature of  $55 (\pm 5) ^\circ\text{C}$ . The maximum pressure cycling rate is ten cycles per minute. Following this test, the pressure relief device shall comply the requirements of Leak test (Annex III, Paragraph 1.8.), Flow rate test (Annex III, Paragraph 1.10.) and Bench top activation test (Annex III Paragraph 1.9.).

##### 1.2 Accelerated Life Test

Eight TPRD units undergo testing; three at the manufacturer's specified activation temperature,  $T_{\text{act}}$ , and five at an accelerated life temperature,  $T_{\text{life}} = 9.1 \times T_{\text{act}}^{0.503}$ . The TPRD is placed in an oven or liquid bath with the temperature held constant ( $\pm 1^\circ\text{C}$ ). The hydrogen gas pressure on the TPRD inlet is 125% NWP ( $\pm 1 \text{ MPa}$ ). The pressure supply may be located outside the controlled temperature oven or bath. Each device is pressured individually or through a manifold system. If a manifold system is used, each pressure connection includes a check valve to prevent pressure depletion of the system when one specimen fails. The three TPRDs tested at  $T_{\text{act}}$  shall activate in less than ten hours. The five TPRDs tested at  $T_{\text{life}}$  shall not activate in less than 500h.

##### 1.3 Temperature Cycling Test

- (a) An unpressurized TPRD is placed in a liquid bath maintained at  $-40^\circ\text{C}$  or lower at least 2h. The TPRD is transferred to a liquid bath maintained at  $+85^\circ\text{C}$  or higher within 5min, and maintained at that temperature at least 2h. The TPRD is transferred to a liquid bath maintained at  $-40^\circ\text{C}$  or lower within 5min;
- (b) Step (a) is repeated until 15 thermal cycles have been achieved;
- (c) With the TPRD conditioned for a minimum of two hours in the  $-40^\circ\text{C}$  or lower liquid bath, the internal pressure of the TPRD is cycled with hydrogen

gas between 2MPa (+1/-0MPa) and 80% NWP (+2/-0MPa) for 100 cycles while the liquid bath is maintained at -40°C or lower;

- (d) Following the thermal and pressure cycling, the pressure relief device shall comply with the requirements of Leak test (Annex III, Paragraph 1.8.), except that the Leak test shall be conducted at -40°C (+5/-0°C). After the Leak test, the TPRD shall comply with the requirements of Bench top activation test (Annex III, Paragraph 1.9.) and then Flow rate test (Annex III, Paragraph 1.10.)

#### 1.4 Salt Corrosion Resistance Test

Two TPRD units are tested. Any non-permanent outlet caps are removed. Each TPRD unit is installed in a test fixture in accordance with the manufacturer's recommended procedure so that external exposure is consistent with realistic installation. Each unit is exposed for 500h to a salt spray (fog) test as specified in ASTM B117 (Standard Practice for Operating Salt Spray (Fog) Apparatus) except that in the test of one unit, the pH of the salt solution shall be adjusted to  $4.0 \pm 0.2$  by the addition of sulphuric acid and nitric acid in a 2:1 ratio, and in the test of the other unit, the pH of the salt solution shall be adjusted to  $10.0 \pm 0.2$  by the addition of sodium hydroxide. The temperature within the fog chamber is maintained at 30-35°C).

Following these tests, each pressure relief device shall comply with the requirements of Leak test (Annex III, Paragraph 1.8.), Flow rate test (Annex III, Paragraph 1.10.) and Bench top activation test (Annex III, Paragraph 1.9.).

#### 1.5 Vehicle Environment Test

Resistance to degradation by external exposure to automotive fluids is determined by the following test:

- (a) The inlet and outlet connections of the TPRD are connected or capped in accordance with the manufacturers installation instructions. The external surfaces of the TPRD are exposed for 24h at 20 ( $\pm 5$ ) °C to each of the following fluids:
- (i) Sulphuric acid (19% solution by volume in water);
  - (ii) Sodium hydroxide (25% solution by weight in water);
  - (iii) Ammonium nitrate (28% by weight in water); and
  - (iv) Windshield washer fluid (50% by volume methyl alcohol and water).

The fluids are replenished as needed to ensure complete exposure for the duration of the test. A distinct test is performed with each of the fluids. One component may be used for exposure to all of the fluids in sequence.

- (b) After exposure to each fluid, the component is wiped off and rinsed with water;
- (c) The component shall not show signs of physical degradation that could impair the function of the component, specifically: cracking, softening, or

swelling. Cosmetic changes such as pitting or staining are not failures. At the conclusion of all exposures, the unit(s) shall comply with the requirements of Leak test (Annex III, Paragraph 1.8.), Flow rate test (Annex III, Paragraph 1.10.) and Bench top activation test (Annex III, Paragraph 1.9.).

#### 1.6 **Stress Corrosion Cracking Test**

For TPRDs containing components made of a copper-based alloy (e.g. brass), one TPRD unit is tested. All copper alloy components exposed to the atmosphere shall be degreased and then continuously exposed for ten days to a moist ammonia-air mixture maintained in a glass chamber having a glass cover.

Aqueous ammonia having a specific gravity of 0.94 is maintained at the bottom of the glass chamber below the sample at a concentration of at least 20ml per litre of chamber volume. The sample is positioned 35 ( $\pm 5$ ) mm above the aqueous ammonia solution and supported in an inert tray. The moist ammonia-air mixture is maintained at atmospheric pressure at 35 ( $\pm 5$ ) °C. Copper-based alloy components shall not exhibit cracking or delaminating due to this test.

#### 1.7 **Drop and Vibration Test**

- (a) Six TPRD units are dropped from a height of 2 m at ambient temperature ( $20 \pm 5$  °C) onto a smooth concrete surface. Each sample is allowed to bounce on the concrete surface after the initial impact. One unit is dropped in six orientations (opposing directions of 3 orthogonal axes: vertical, lateral and longitudinal). If each of the six dropped samples does not show visible exterior damage that indicates that the part is unsuitable for use, it shall proceed to step (b);
- (b) Each of the six TPRD units dropped in step (a) and one additional unit not subjected to a drop are mounted in a test fixture in accordance with manufacturer's installation instructions and vibrated 30min along each of the three orthogonal axes (vertical, lateral and longitudinal) at the most severe resonant frequency for each axis. The most severe resonant frequencies are determined using an acceleration of 1.5g and sweeping through a sinusoidal frequency range of 10 to 500Hz within 10min. The resonance frequency is identified by a pronounced increase in vibration amplitude. If the resonance frequency is not found in this range, the test shall be conducted at 40Hz. Following this test, each sample shall not show visible exterior damage that indicates that the part is unsuitable for use. It shall subsequently comply with the requirements of Leak test (Annex III, Paragraph 1.8.), Flow rate test (Annex III, Paragraph 1.10.) and Bench top activation test (Annex III, Paragraph 1.9.).

#### 1.8 **Leak Test**

A TPRD that has not undergone previous testing is tested at ambient, high and low temperatures without being subjected to other design qualification tests. The unit is held for one hour at each temperature and test pressure before testing. The three temperature test conditions are:

- (a) Ambient temperature: condition the unit at 20 ( $\pm 5$ ) °C; test at 5% NWP

(+0/-2MPa) and 150% NWP (+2/-0MPa);

- (b) High temperature: condition the unit at 85°C or higher; test at 5% NWP (+0/-2MPa) and 150% NWP (+2/-0MPa);
- (c) Low temperature: condition the unit at -40°C or lower; test at 5% NWP (+0/-2MPa) and 100% NWP (+2/-0MPa).

Additional units undergo leak testing as specified in other tests in Annex III, Paragraph 1. With uninterrupted exposure at the temperature specified in those tests.

At all specified test temperatures, the unit is conditioned for one minute by immersion in a temperature-controlled fluid (or equivalent method). If no bubbles are observed for the specified time period, the sample passes the test. If bubbles are detected, the leak rate is measured by an appropriate method. The total hydrogen leak rate shall be less than 10 Nml/hr.

### 1.9 **Bench Top Activation Test**

Two new TPRD units are tested without being subjected to other design qualification tests in order to establish a baseline time for activation. Additional pre-tested units (pre-tested according to Annex III, Paragraphs 1.1., 1.3., 1.4., 1.5. or 1.7.) undergo bench top activation testing as specified in other tests in Annex III, Paragraph 1.

- (a) The test setup consists of either an oven or chimney which is capable of controlling air temperature and flow to achieve 600 ( $\pm 10$ ) °C in the air surrounding the TPRD. The TPRD unit is not exposed directly to flame. The TPRD unit is mounted in a fixture according to the manufacturer's installation instructions; the test configuration is to be documented;
- (b) A thermocouple is placed in the oven or chimney to monitor the temperature. The temperature remains within the acceptable range for 2 min prior to running the test;
- (c) The pressurized TPRD unit is inserted into the oven or chimney, and the time for the device to activate is recorded. Prior to insertion into the oven or chimney, one new (not pre-tested) TPRD unit is pressurized to no more than 25% NWP (the pre-tested); TPRD units are pressurized to no more than 25% NWP; and one new (not pre-tested) TPRD unit is pressurized to 100% NWP;
- (d) TPRD units previously subjected to other tests in Annex III, Paragraph 1. shall activate within a period no more than 2min longer than the baseline activation time of the new TPRD unit that was pressurized to up to 25% NWP;
- (e) The difference in the activation time of the two TPRD units that had not undergone previous testing shall be no more than 2min.

### 1.10 **Flow Rate Test**

- (a) Eight TPRD units are tested for flow capacity. The eight units consist of

three new TPRD units and one TPRD unit from each of the following previous tests: Annex III, Paragraphs 1.1., 1.3., 1.4., 1.5. and 1.7.;

- (b) Each TPRD unit is activated according to Annex 4, Paragraph 1.9. After activation and without cleaning, removal of parts, or reconditioning, each TPRD unit is subjected to flow test using hydrogen, air or an inert gas;
- (c) Flow rate testing is conducted with a gas inlet pressure of 2 ( $\pm 0.5$ ) MPa. The outlet is at ambient pressure. The inlet temperature and pressure are recorded;
- (d) Flow rate is measured with accuracy within  $\pm 2\%$ . The lowest measured value of the eight pressure relief devices shall not be less than 90% of the highest flow value.

## 2.0 TESTS FOR CHECK VALVE AND SHUT-OFF VALVE

Testing shall be performed with hydrogen gas having gas quality compliant with ISO 14687-2/SAE J2719. All tests are performed at ambient temperature 20 ( $\pm 5$ ) °C unless otherwise specified. The check valve and shut-off valve qualification performance tests are specified as follows (see also Appendix 2):

### 2.1 Hydrostatic Strength Test

The outlet opening in components is plugged and valve seats or internal blocks are made to assume the open position. One unit is tested without being subjected to other design qualification tests in order to establish a baseline burst pressure, other units are tested as specified in subsequent tests of Annex III, Paragraph 2.

- (a) A hydrostatic pressure of 250 % NWP ( $+2/-0$ MPa) is applied to the inlet of the component for three minutes. The component is examined to ensure that rupture has not occurred;
- (b) The hydrostatic pressure is then increased at a rate of less than or equal to 1.4 MPa/s until component failure. The hydrostatic pressure at failure is recorded. The failure pressure of previously tested units shall be no less than 80 % of the failure pressure of the baseline, unless the hydrostatic pressure exceeds 400 % NWP.

### 2.2 Leak Test

One unit that has not undergone previous testing is tested at ambient, high and low temperatures without being subjected to other design qualification tests. The three temperature test conditions are:

- (a) Ambient temperature: condition the unit at 20 ( $\pm 5$ ) °C; test at 5% NWP ( $+0/-2$ MPa) and 150% NWP ( $+2/-0$ MPa);
- (b) High temperature: condition the unit at 85°C or higher; test at 5% NWP ( $+0/-2$ MPa) and 150% NWP ( $+2/-0$ MPa);
- (c) Low temperature: condition the unit at -40°C or lower; test at 5% NWP ( $+0/-2$ MPa) and 100% NWP ( $+2/-0$ MPa).

Additional units undergo leak testing as specified in other tests in Annex III, Paragraph 2. With uninterrupted exposure at the temperatures specified in those tests.

The outlet opening is plugged with the appropriate mating connection and pressurized hydrogen is applied to the inlet. At all specified test temperatures, the unit is conditioned for one minute by immersion in a temperature-controlled fluid (or equivalent method). If no bubbles are observed for the specified time period, the sample passes the test. If bubbles are detected, the leak rate is measured by an appropriate method. The leak rate shall not exceed 10 Nml/hr of hydrogen gas.

### 2.3 Extreme Temperature Pressure Cycling Test

- (a) The total number of operational cycles is 11,000 for a 15-year service life or 15,000 operational cycles for a 20-year service life for the check valve and 50,000 for a 15-year service life or 67,000 operational cycles for a 20-year service life for the shut-off valve. The valve unit are installed in a test fixture corresponding to the manufacturer's specifications for installation. The operation of the unit is continuously repeated using hydrogen gas at all specified pressures.

An operational cycle shall be defined as follows:

- (i) A check valve is connected to a test fixture and 100% NWP (+2/-0MPa) is applied in six step pulses to the check valve inlet with the outlet closed. The pressure is then vented from the check valve inlet. The pressure is lowered on the check valve outlet side to less than 60% NWP prior to the next cycle;
- (ii) A shut-off valve is connected to a test fixture and pressure is applied continuously to the both the inlet and outlet sides.

An operational cycle consists of one full operation and reset.

- (b) Testing is performed on a unit stabilized at the following temperatures:

- (i) Ambient temperature cycling. The unit undergoes operational (open/closed) cycles at 125% NWP (+2/-0MPa) through 90% of the total cycles with the part stabilized at 20 ( $\pm 5$ ) °C. At the completion of the ambient temperature operational cycles, the unit shall comply with the ambient temperature leak test specified in Annex III, Paragraph 2.2.;
- (ii) High temperature cycling. The unit then undergoes operational cycles at 125% NWP (+2/-0MPa) through 5% of the total operational cycles with the part stabilized at 85°C or higher. At the completion of the 85°C cycles, the unit shall comply with the high temperature (85°C) leak test specified in Annex III, Paragraph 2.2.;
- (iii) Low temperature cycling. The unit then undergoes operational cycles at 100% NWP (+2/-0MPa) through 5% of the total cycles with the part stabilized at -40°C or lower. At the completion of the -40°C operational cycles, the unit shall comply with the low temperature (-40°C) leak test specified in Annex III, Paragraph 2.2.

- (c) Check valve chatter flow test: Following 11,000 operational cycles for a 15-year service life or 15,000 operational cycles for a 20-year service life and leak tests in Annex 4, Paragraph 2.3 (b), the check valve is subjected to 24h of chatter flow at a flow rate that causes the most chatter (valve flutter). At the completion of the test the check valve shall comply with the ambient temperature leak test (Annex III, Paragraph 2.2.) and the strength test (Annex III, Paragraph 2.1.).

#### 2.4 **Salt Corrosion Resistance Test**

The component is supported in its normally installed position and exposed for 500h to a salt spray (fog) test as specified in ASTM B117 (Standard Practice for Operating Salt Spray (Fog) Apparatus). The temperature within the fog chamber is maintained at 30-35°C). The saline solution consists of 5% sodium chloride and 95% distilled water, by weight.

Immediately after the corrosion test, the sample is rinsed and gently cleaned of salt deposits, examined for distortion, and then shall comply with the requirements of:

- (a) The component shall not show signs of physical degradation that could impair the function of the component, specifically: cracking, softening or swelling. Cosmetic changes such as pitting or staining are not failures;
- (b) The ambient temperature leak test (Annex III, Paragraph 2.2.);
- (c) The hydrostatic strength test (Annex III, Paragraph 2.1.).

#### 2.5 **Vehicle Environment Test**

Resistance to degradation by exposure to automotive fluids is determined by the following test.

- (a) The inlet and outlet connections of the valve unit are connected or capped in accordance with the manufacturers installation instructions. The external surfaces of the valve unit are exposed for 24h at 20 ( $\pm 5$ ) °C to each of the following fluids:
  - (i) Sulphuric acid -19% solution by volume in water;
  - (ii) Sodium hydroxide -25% solution by weight in water;
  - (iii) Ammonium nitrate -28% by weight in water; and
  - (iv) Windshield washer fluid (50% by volume methyl alcohol and water).

The fluids are replenished as needed to ensure complete exposure for the duration of the test. A distinct test is performed with each of the fluids. One component may be used for exposure to all of the fluids in sequence.

- (b) After exposure to each chemical, the component is wiped off and rinsed with water;
- (c) The component shall not show signs of physical degradation that could

impair the function of the component, specifically: cracking, softening, or swelling. Cosmetic changes such as pitting or staining are not failures. At the conclusion of all exposures, the unit(s) shall comply with the requirements of the ambient temperature leakage test (Annex III, Paragraph 2.2.) and Hydrostatic Strength Test (Annex III, Paragraph 2.1.).

## 2.6 Atmospheric Exposure Test

The atmospheric exposure test applies to qualification of check valve and automatic shut-off valves if the component has non-metallic materials exposed to the atmosphere during normal operating conditions.

- (a) All non-metallic materials that provide a fuel containing seal, and that are exposed to the atmosphere, for which a satisfactory declaration of properties is not submitted by the applicant, shall not crack or show visible evidence of deterioration after exposure to oxygen for 96h at 70°C at 2 MPa in accordance with ASTM D572 (Standard Test Method for Rubber-deterioration by Heat and Oxygen);
- (b) All elastomers shall demonstrate resistance to ozone by one or more of the following:
  - (i) Specification of elastomer compounds with established resistance to ozone;
  - (ii) Component testing in accordance with ISO 1431/1, ASTM D1149, or equivalent test methods.

## 2.7 Electrical Tests

The electrical tests apply to qualification of the automatic shut-off valve; they do not apply to qualification of check valves.

- (a) Abnormal voltage test. The solenoid valve is connected to a variable DC voltage source. The solenoid valve is operated as follows:
  - (i) An equilibrium (steady state temperature) hold is established for 1h at 1.5 times the rated voltage;
  - (ii) The voltage is increased to two times the rated voltage or 60V, whichever is less, and held for one minute;
  - (iii) Any failure shall not result in external leakage, open valve or unsafe conditions such as smoke, fire or melting.

The minimum opening voltage at NWP and room temperature shall be less than or equal to 9V for a 12V system and less than or equal to 18V for a 24V system.

- (b) Insulation resistance test. 1,000V D.C. is applied between the power conductor and the component casing for at least 2s. The minimum allowable resistance for that component is 240k Ohm.

## 2.8 **Vibration Test**

The valve unit is pressurized to its 100% NWP (+2/-0MPa) with hydrogen, sealed at both ends, and vibrated for 30min along each of the three orthogonal axes (vertical, lateral and longitudinal) at the most severe resonant frequencies. The most severe resonant frequencies are determined by acceleration of 1.5g with a sweep time of 10min within a sinusoidal frequency range of 10 to 40Hz. If the resonance frequency is not found in this range the test is conducted at 40Hz. Following this test, each sample shall not show visible exterior damage that indicates that the performance of the part is compromised. At the completion of the test, the unit shall comply with the requirements of the ambient temperature leak test specified in Annex III, Paragraph 2.2.

## 2.9 **Stress Corrosion Cracking Test**

For the valve units containing components made of a copper-based alloy (e.g. brass), one valve unit is tested. The valve unit is disassembled, all copper-based alloy components are degreased and then the valve unit is reassembled before it is continuously exposed for ten days to a moist ammonia-air mixture maintained in a glass chamber having a glass cover.

Aqueous ammonia having a specific gravity of 0.94 is maintained at the bottom of the glass chamber below the sample at a concentration of at least 20ml per litre of chamber volume. The sample is positioned 35 ( $\pm 5$ ) mm above the aqueous ammonia solution and supported in an inert tray. The moist ammonia-air mixture is maintained at atmospheric pressure at 35 ( $\pm 5$ ) °C. Copper-based alloy components shall not exhibit cracking or delaminating due to this test.

## 2.10 **Pre-cooled Hydrogen Exposure Test**

The valve unit is subjected to pre-cooled hydrogen gas at -40°C or lower at a flow rate of 30g/s at external temperature of 20 ( $\pm 5$ ) °C for a minimum of 3min. The unit is de-pressurized and re-pressurized after a 2min hold period. This test is repeated ten times. This test procedure is then repeated for an additional ten cycles, except that the hold period is increased to 15min. The unit shall then comply with the requirements of the ambient temperature leak test specified in Annex III, Paragraph 2.2.

ANNEX III – APPENDIX 1

Overview of TPRD tests

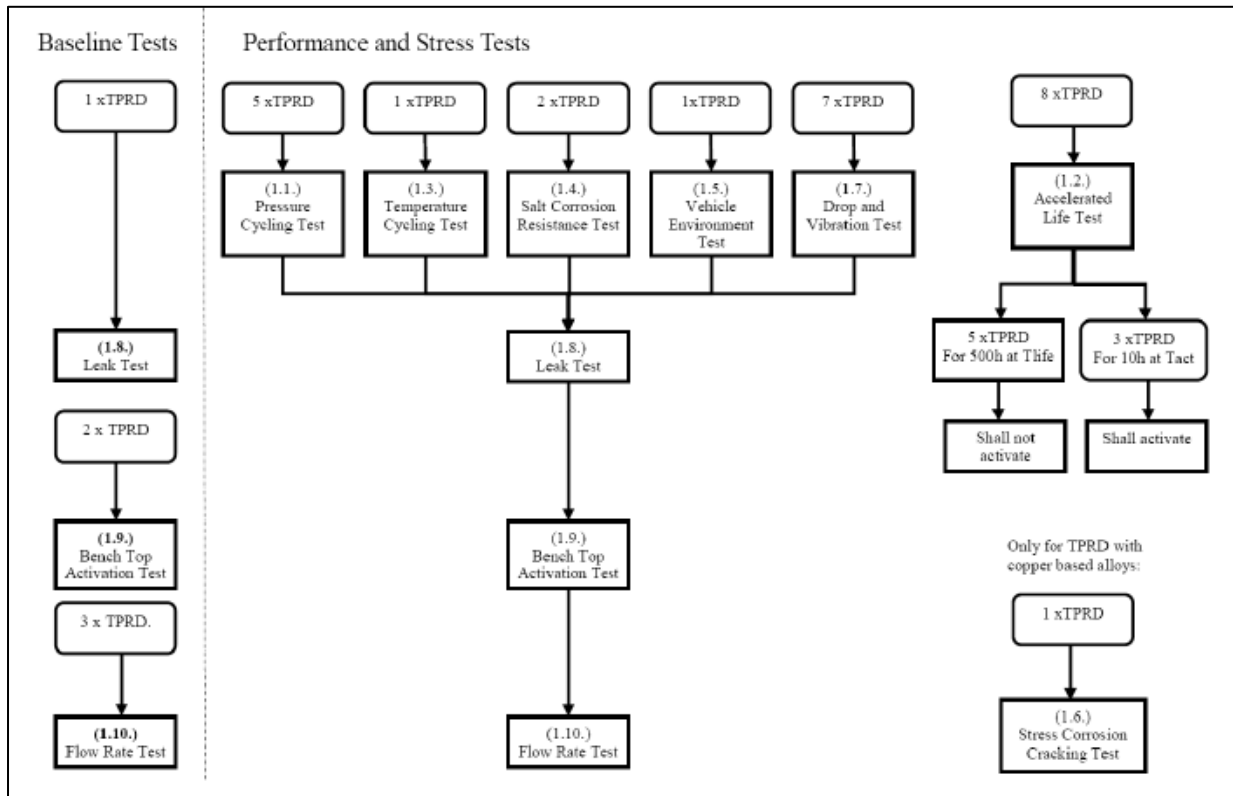

ANNEX III – APPENDIX 2

Overview of Check valve and Automatic shut-off valve tests

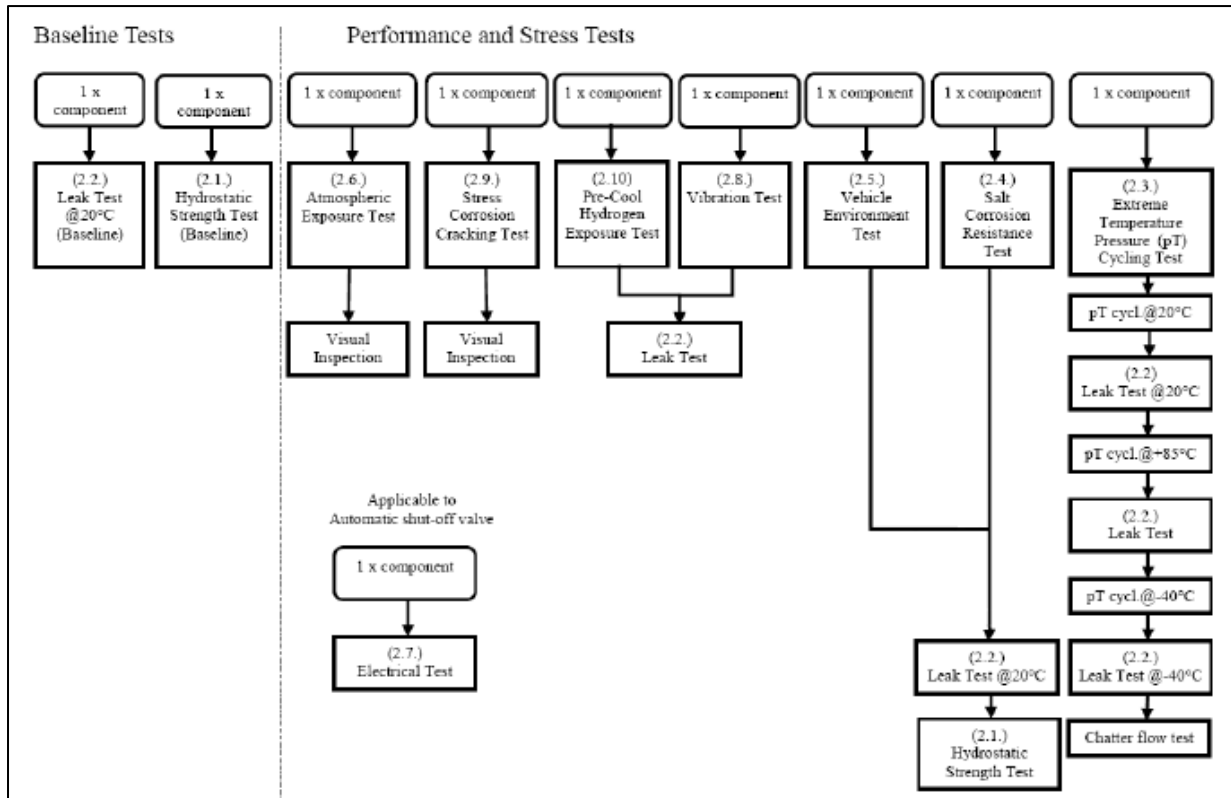

## ANNEXURE IV

**Test procedures for a vehicle fuel system incorporating the compressed gaseous hydrogen storage system****1.0 POST-CRASH COMPRESSED GASEOUS HYDROGEN STORAGE SYSTEM LEAK TEST**

The crash tests used to evaluate post-crash hydrogen leakage are those set out in Paragraph 7.2. of this Standard.

Prior to conducting the crash test, instrumentation is installed in the hydrogen storage system to perform the required pressure and temperature measurements if the standard vehicle does not already have instrumentation with the required accuracy.

The storage system is then purged, if necessary, following manufacturer's directions to remove impurities from the container before filling the storage system with compressed gaseous hydrogen or helium gas. Since the storage system pressure varies with temperature, the targeted fill pressure is a function of the temperature. The target pressure shall be determined from the following equation:

$$P_{\text{target}} = \text{NWP} \times (273 + T_0)/288$$

Where NWP is the Nominal Working Pressure (MPa),  $T_0$  is the ambient temperature to which the storage system is expected to settle, and  $P_{\text{target}}$  is the targeted fill pressure after the temperature settles.

The container is filled to a minimum of 95% of the targeted fill pressure and allowed to settle (stabilize) prior to conducting the crash test.

The main stop valve and shut-off valves for hydrogen gas, located in the downstream hydrogen gas piping, are in normal driving condition immediately prior to the impact.

**1.1 Post-crash Leak Test: Compressed Gaseous Hydrogen Storage System Filled with Compressed Gaseous Hydrogen**

The hydrogen gas pressure,  $P_0$  (MPa) and temperature,  $T_0$  (°C) are measured immediately before the impact and then at a time interval,  $\Delta t$  (min), after the impact. The time interval,  $\Delta t$ , starts when the vehicle comes to rest after the impact and continues for at least 60min. The time interval,  $\Delta t$ , shall be increased, if necessary, to accommodate measurement accuracy for a storage system with a large volume operating up to 70MPa; in that case,  $\Delta t$  is calculated from the following equation:

$$\Delta t = V_{\text{CHGS}} \times \text{NWP} / 1,000 \times ((-0.027 \times \text{NWP} + 4) \times R_s - 0.21) - 1.7 \times R_s$$

Where  $R_s = P_s/\text{NWP}$ ,  $P_s$  is the pressure range of the pressure sensor (MPa), NWP

is the Nominal Working Pressure (MPa), VCHSS is the volume of the compressed gaseous hydrogen storage system (L), and  $\Delta t$  is the time interval (min). If the calculated value of  $\Delta t$  is less than 60min,  $\Delta t$  is set to 60 min.

The initial mass of hydrogen in the storage system is calculated as follows:

$$P_o' = P_o \times 288 / (273 + T_o)$$

$$\rho_o' = -0.0027 \times (P_o')^2 + 0.75 \times P_o' + 0.5789$$

$$M_o = \rho_o' \times V_{CHSS}$$

The final mass of hydrogen in the storage system,  $M_f$ , at the end of the time interval,  $\Delta t$ , is calculated as follows:

$$P_f' = P_f \times 288 / (273 + T_f)$$

$$\rho_f' = -0.0027 \times (P_f')^2 + 0.75 \times P_f' + 0.5789$$

$$M_f = \rho_f' \times V_{CHSS}$$

Where  $P_f$  is the measured final pressure (MPa) at the end of the time interval, and  $T_f$  is the measured final temperature ( $^{\circ}\text{C}$ ).

The average hydrogen flow rate over the time interval (that shall be less than the criteria in Paragraph 7.2.1.) is therefore:

$$V_{H_2} = (M_f - M_o) / \Delta t \times 22.41 / 2.016 \times (P_{target} / P_o)$$

Where  $V_{H_2}$  is the average volumetric flow rate (NL/min) over the time interval and the term  $(P_{target} / P_o)$  is used to compensate for differences between the measured initial pressure,  $P_o$ , and the targeted fill pressure  $P_{target}$ .

## 1.2 Post-crash Leak Test: Compressed Gaseous Hydrogen Storage System Filled with Compressed Helium

The helium gas pressure,  $P_0$  (MPa), and temperature  $T_0$  ( $^{\circ}\text{C}$ ), are measured immediately before the impact and then at a predetermined time interval after the impact. The time interval,  $\Delta t$ , starts when the vehicle comes to rest after the impact and continues for at least 60min. The time interval,  $\Delta t$ , shall be increased if necessary in order to accommodate measurement accuracy for a storage system with a large volume operating up to 70MPa; in that case,  $\Delta t$  is calculated from the following equation:

$$\Delta t = V_{CHSS} \times NWP / 1,000 \times ((-0.028 \times NWP + 5.5) \times R_s - 0.3) - 2.6 \times R_s$$

where  $R_s = P_s/NWP$ ,  $P_s$  is the pressure range of the pressure sensor (MPa),  $NWP$  is the Nominal Working Pressure (MPa),  $V_{CHSS}$  is the volume of the compressed storage system (L), and  $\Delta t$  is the time interval (min). If the value of  $\Delta t$  is less than 60min,  $\Delta t$  is set to 60min

The initial mass of helium in the storage system is calculated as follows:

$$P_o' = P_o \times 288 / (273 + T_o)$$

$$\rho_o' = -0.0043 \times (P_o')^2 + 1.53 \times P_o' + 1.49$$

$$M_o = \rho_o' \times V_{CHSS}$$

The final mass of helium in the storage system,  $M_f$ , at the end of the time interval,  $\Delta t$ , is calculated as follows:

$$P_f' = P_f \times 288 / (273 + T_f)$$

$$\rho_f' = -0.0043 \times (P_f')^2 + 1.53 \times P_f' + 1.49$$

$$M_f = \rho_f' \times V_{CHSS}$$

Where  $P_f$  is the measured final pressure (MPa) at the end of the time interval, and  $T_f$  is the measured final temperature ( $^{\circ}\text{C}$ ).

The average helium flow rate over the time interval is therefore:

$$V_{He} = (M_f - M_o) / \Delta t \times 22.41 / 4.003 \times (P_{target} / P_o)$$

Where  $V_{He}$  is the average volumetric flow rate (NL/min) over the time interval and the term  $P_{target}/P_o$  is used to compensate for differences between the measured initial pressure ( $P_o$ ) and the targeted fill pressure ( $P_{target}$ ).

Conversion of the average volumetric flow of helium to the average hydrogen flow is calculated with the following expression:

$$V_{H_2} = V_{He} / 0.75$$

Where  $V_{H_2}$  is the corresponding average volumetric flow of hydrogen (that shall be less than the requirements in Paragraph 7.2.1. of this Standard to comply with).

## 2.0 POST-CRASH CONCENTRATION TEST FOR ENCLOSED SPACES

The measurements are recorded in the crash test that evaluates potential hydrogen (or helium) leakage (Annex IV, Paragraph 1. test procedure).

Sensors are selected to measure either the build-up of the hydrogen or helium gas

or the reduction in oxygen (due to displacement of air by leaking hydrogen/helium).

Sensors are calibrated to traceable references to ensure an accuracy of  $\pm 5\%$  at the targeted criteria of 4% hydrogen or 3% helium by volume in air, and a full-scale measurement capability of at least 25% above the target criteria. The sensor shall be capable of a 90% response to a full-scale change in concentration within 10s.

Prior to the crash impact, the sensors are located in the passenger and, luggage compartments of the vehicle as follows:

- (a) At a distance within 250mm of the headliner above the driver's seat or near the top centre the passenger compartment;
- (b) At a distance within 250mm of the floor in front of the rear (or rear most) seat in the passenger compartment;
- (c) At a distance within 100mm of the top of luggage compartments within the vehicle that are not directly affected by the particular crash impact to be conducted.

The sensors are securely mounted on the vehicle structure or seats and protected for the planned crash test from debris, air bag exhaust gas and projectiles. The measurements following the crash are recorded by instruments located within the vehicle or by remote transmission.

The vehicle may be located either outdoors in an area protected from the wind and possible solar effects or indoors in a space that is large enough or ventilated to prevent the build-up of hydrogen to more than 10% of the targeted criteria in the passenger and luggage compartments.

Post-crash data collection in enclosed spaces commences when the vehicle comes to a rest. Data from the sensors are collected at least every 5s and continue for a period of 60min after the test. A first-order lag (time constant) up to a maximum of 5s may be applied to the measurements to provide "smoothing" and filter the effects of spurious data points.

The filtered readings from each sensor shall be below the targeted criteria of 4.0% for hydrogen or 3.0% for helium at all times throughout the 60min post-crash test period.

### **3.0 COMPLIANCE TEST FOR SINGLE FAILURE CONDITIONS**

Either test procedure of Annex IV, Paragraph 3.1. or Paragraph 3.2. shall be executed:

#### **3.1 Test procedure for Vehicle Equipped with Hydrogen Gas Leakage Detectors**

##### **3.1.1 Test Condition**

- 3.1.1.1 Test vehicle: The propulsion system of the test vehicle is started, warmed up to its normal operating temperature, and left operating for the test duration. If the vehicle is not a fuel cell vehicle, it is warmed up and kept idling. If the test vehicle has a system to stop idling automatically, measures are taken so as to prevent the engine from stopping.

- 3.1.1.2 Test gas: Two mixtures of air and hydrogen gas: 3.0% concentration (or less) of hydrogen in the air to verify function of the warning, and 4.0% concentration (or less) of hydrogen in the air to verify the shut-down function. The proper concentrations are selected based on the recommendation (or the detector specification) by the manufacturer.
- 3.1.2 Test Method
  - 3.1.2.1 Preparation for the test: The test is conducted without any influence of wind by appropriate means such as:
    - (a) A test gas induction hose is attached to the hydrogen gas leakage detector;
    - (b) The hydrogen leak detector is enclosed with a cover to make gas stay around hydrogen leak detector.
  - 3.1.2.2 Execution of the Test
    - (a) Test gas is blown to the hydrogen gas leakage detector;
    - (b) Proper function of the warning system is confirmed when tested with the gas to verify function of the warning;
    - (c) The main shut-off valve is confirmed to be closed when tested with the gas to verify function of the shut-down. For example, the monitoring of the electric power to the shut-off valve or of the sound of the shut-off valve activation may be used to confirm the operation of the main shut-off valve of the hydrogen supply.
- 3.2 Test Procedure for Integrity of Enclosed Spaces and Detection Systems
  - 3.2.1 Preparation:
    - 3.2.1.1 The test is conducted without any influence of wind
    - 3.2.1.2 Special attention is paid to the test environment as during the test, flammable mixtures of hydrogen and air may occur.
    - 3.2.1.3 Prior to the test the vehicle is prepared to simulate remotely controllable hydrogen releases from the hydrogen system. Hydrogen releases may be demonstrated by using external fuel supply without modification of the test vehicle fuel lines. The number, location and flow capacity of the release points downstream of the main hydrogen shutoff valve are defined by the vehicle manufacturer taking worst case leakage scenarios into account. As a minimum, the total flow of all remotely controlled releases shall be adequate to trigger demonstration of the automatic "warning" and hydrogen shut-off functions
    - 3.2.1.4 For the purpose of the test, a hydrogen concentration detector is installed where hydrogen gas may accumulate most in the passenger compartment (e.g. near the headliner) when testing for compliance with Paragraph 7.1.4.2. of this Standard and hydrogen concentration detector are installed in enclosed or semi enclosed volumes on the vehicle where hydrogen can accumulate from the simulated hydrogen releases when testing for compliance with Paragraph 7.1.4.3. of this

Standard (see Annex IV, Paragraph 3.2.1.3.).

3.2.2 Procedure:

3.2.2.1 Vehicle doors, windows and other covers are closed

3.2.2.2 The propulsion system is started, allowed to warm up to its normal operating temperature and left operating at idle for the test duration

3.2.2.3 A leak is simulated using the remote controllable function.

3.2.2.4 The hydrogen concentration is measured continuously until the concentration does not rise for 3min. When testing for compliance with Paragraph 7.1.4.3 of this Standard, the simulated leak is then increased using the remote controllable function until the main hydrogen shut-off valve is closed and the tell-tale warning signal is activated. The monitoring of the electric power.

to the shut-off valve or of the sound of the shut-off valve activation may be used to confirm the operation of the main shut-off valve of the hydrogen supply.

3.2.2.5 When testing for compliance with Paragraph 7.1.4.2. of this Standard, the test is successfully completed if the hydrogen concentration in the passenger compartment does not exceed 1.0%. When testing for compliance with Paragraph 7.1.4.3. of this Standard, the test is successfully completed if the tell-tale warning and shut-off function are executed at (or below) the levels specified in Paragraph 7.1.4.3. of this Standard; otherwise, the test is failed and the system is not qualified for vehicle service.

#### **4.0 COMPLIANCE TEST FOR THE VEHICLE EXHAUST SYSTEM**

4.1 The power system of the test vehicle (e.g. fuel cell stack or engine) is warmed up to its normal operating temperature.

4.2 The measuring device is warmed up before use to its normal operating temperature.

4.3 The measuring section of the measuring device is placed on the centre line of the exhaust gas flow within 100mm from the exhaust point of discharge external to the vehicle.

4.4 The exhaust hydrogen concentration is continuously measured during the following steps:

(a) The power system is shut-down;

(b) Upon completion of the shut-down process, the power system is immediately started;

(c) After a lapse of 1min, the power system is turned off and measurement continues until the power system shut-down procedure is completed

4.5 The measurement device shall have a measurement response time of less than 300ms.

**5.0 COMPLIANCE TEST FOR FUEL LINE LEAKAGE**

- 5.1 The power system of the test vehicle (e.g. fuel cell stack or engine) is warmed up and operating at its normal operating temperature with the operating pressure applied to fuel lines.
- 5.2 Hydrogen leakage is evaluated at accessible sections of the fuel lines from the high-pressure section to the fuel cell stack (or the engine), using a gas leak detector or a leak detecting liquid, such as soap solution.
- 5.3 Hydrogen Leak Detection is Performed Primarily at Joints
- 5.4 When a gas leak detector is used, detection is performed by operating the leak detector for at least 10s at locations as close to fuel lines as possible.
- 5.5 When a leak detecting liquid is used, hydrogen gas leak detection is performed immediately after applying the liquid. In addition, visual checks are performed a few minutes after the application of liquid to check for bubbles caused by trace leaks.

**6.0 INSTALLATION VERIFICATION**

The system is visually inspected for compliance.

## ANNEXURE V

**Vehicle Identification Requirements (Compressed gaseous hydrogen)  
(para 7.9)**

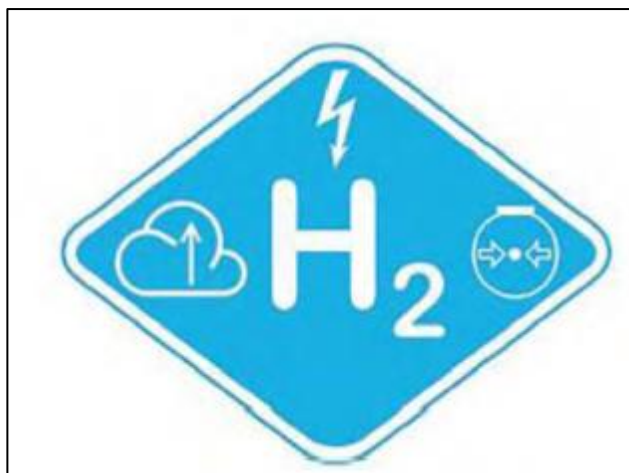

- |    |   |
|----|---|
| a. | The label shall be weather resistant.   |
| b. | The centre zone indicates the first energy source   |
| c. | The upper zone indicates the second energy source   |
| d. | The left zone indicates the gas behaviour due to density  |
| e. | The right zone indicates the state of aggregation of stored gaseous fuel  |
| f. | Layout and symbols shall be in accordance with ISO 17840-4: 2018  |
| g. | The colour and dimensions of the label shall fulfil the following requirements:   |
| h. | Colours:<br>Background: Light blue, RGB code 0, 176, 240<br>Border: white reflecting<br>Letters and symbols: white reflecting |
| i. | Dimensions:<br>Sticker width: $\geq 110\text{mm}$<br>Sticker height: $\geq 80\text{mm}$                                       |

## ANNEXURE VI

**Approval testing for compressed gaseous hydrogen storage system (CHSS)  
modifications**

1. Modifications to an existing type approval of CHSS may be approved in accordance with the reduced test programme specified in Table 1 below.
2. For modifications not specified in Table 1, the necessary test programme shall be identified by the Technical Service taking account of the similarities of the intended modification to the items specified in the Table 1.

**Table 1  
Change of Design**

Changed Item	Required Tests
Metallic container or liner material	<ul style="list-style-type: none"> <li>- Initial burst, Initial pressure cycle life</li> <li>- Sequential hydraulic tests</li> <li>- Fire test</li> </ul>
Plastic liner material	<ul style="list-style-type: none"> <li>- Initial pressure cycle life</li> <li>- Sequential hydraulic tests</li> <li>- Sequential pneumatic tests</li> <li>- Fire test</li> </ul>
Fiber material <sup>(1)</sup>	<ul style="list-style-type: none"> <li>- Initial burst, Initial pressure cycle life</li> <li>- Sequential hydraulic tests</li> <li>- Fire test</li> </ul>
Resin material	<ul style="list-style-type: none"> <li>- Initial burst, Initial pressure cycle life</li> <li>- Sequential hydraulic tests</li> <li>- Fire test</li> </ul>
Diameter <sup>(2)</sup> ≤20%  >20%	<ul style="list-style-type: none"> <li>- Initial burst, Initial pressure cycle life</li> <li>- Initial burst, Initial pressure cycle life</li> <li>- Sequential hydraulic tests</li> <li>- Fire test</li> </ul>
Length ≤50%  >50%	<ul style="list-style-type: none"> <li>- Initial burst, Initial pressure cycle life</li> <li>- Fire test<sup>(3)</sup></li> <li>- Initial burst, Initial pressure cycle life</li> <li>- Sequential hydraulic tests</li> </ul>

	- Fire test <sup>(3)</sup>
Coating	- Sequential hydraulic tests - Fire test <sup>(4)</sup>
Boss <sup>(5)</sup> Material, geometry, opening size Sealing (liner and/or valve interface)	- Initial burst, Initial pressure cycle life - Sequential pneumatic tests
Fire protection system	- Fire test
Valve change <sup>(6)</sup>	- Sequential pneumatic tests - Fire test <sup>(7)</sup>

Notes:

- (1) Change of fiber type, e.g., glass to carbon is not applicable. Change of design applies only to changes of materials properties or manufacturer within a fiber type.
- (2) Only when thickness change is proportional to diameter change.
- (3) Fire test is not required, provided safety relief devices or device configuration passed the required fire test on a container with equal or greater internal water volume.
- (4) Fire test required if coating affects fire performance.
- (5) Tests are not required if the stresses in the neck are equal to the original stresses or reduced by the design change (e.g., reducing the diameter of internal threads, or changing the boss length), the liner to boss interface is not affected, and the original materials are used for boss, liner, and seals.
- (6) Alternative valve shall be approved in accordance with Part II.
- (7) Fire test not required if TPRD design has not been changed, and the mass of the changed valve is  $\pm 30\%$  of the original valve.

## ANNEXURE VII

**Technical Specification of Hydrogen Powered Vehicles to Be Submitted by Vehicle Manufacturer**

<b>1.0</b>	<b>General description of vehicle</b>	
1.1	Name of the manufacturer	
1.2	Vehicle model name	
1.3	Vehicle type & category	
1.4	Variants (if any)	
1.5	Hydrogen propulsion compressed (gaseous) hydrogen	
<b>2.0</b>	<b>Hydrogen Cylinder (PESO Approved / Endorsed)</b>	
2.1	Make	
2.2	Identification No.	
2.3	Working pressure (kg/cm <sup>2</sup> )	
2.4	Max. test pressure (kg/cm <sup>2</sup> )	
2.5	Cylinder capacity (water equivalent)	
2.6	Approval No.	
<b>3.0</b>	<b>Cylinder Valves (PESO Approved/Endorsed)</b>	
3.1	Make	
3.2	Model name/Identification No.	
3.3	Type	
3.4	Working pressure (kg/cm <sup>2</sup> )	
3.5	Max. test pressure (kg/cm <sup>2</sup> )	
3.6	Approval No.	
<b>4.0</b>	<b>Pressure Relief Device</b>	
4.1	Make	
4.2	Model name/Identification No.	
4.3	Type	

4.4	Working pressure (kg/cm <sup>2</sup> )	
4.5	Max. test pressure (kg/cm <sup>2</sup> )	
4.6	Approval No.	
<b>5.0</b>	<b>Check valve</b>	
5.1	Make	
5.2	Model name/Identification No.	
5.3	Type	
5.4	Working pressure (kg/cm <sup>2</sup> )	
5.5	Max. test pressure (kg/cm <sup>2</sup> )	
5.6	Approval No.	

ANNEXURE VIII

**Typical Liquefied Hydrogen Storage System (LHSS) (Requirements stated in this Annexure shall be taken as reference for the purpose of developmental study and as & when development matures on LHSS, requirements can be further reviewed & suitably considered for approval)**

- 1.0 LHSS comprises of following components
  - a. Container
  - b. Shut off devices
  - c. Boil-off system
  - d. Pressure relief devices
  - e. Interconnecting piping (if any) and fittings

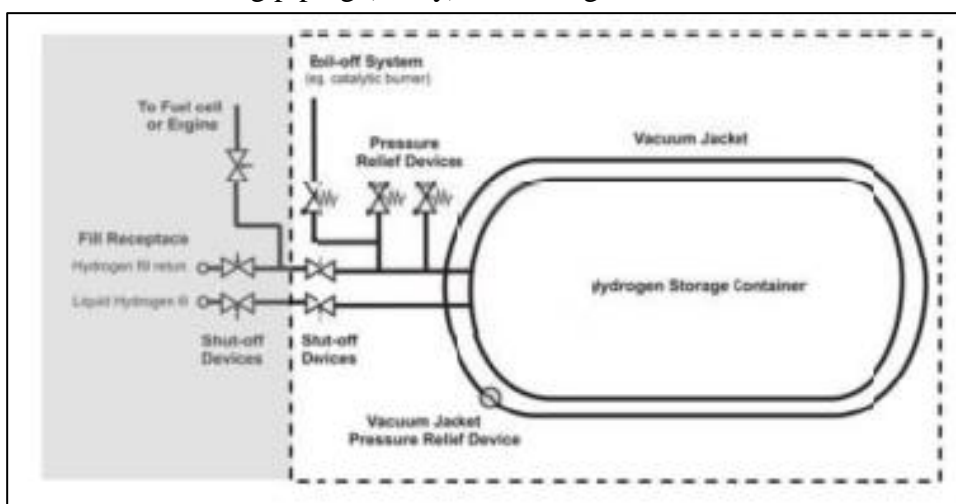

**1.1 LHSS Design Qualification Requirements**

This Section specifies the requirements for the integrity of a liquefied hydrogen storage system. The hydrogen storage system qualifies for the performance test requirements specified in this Section. All liquefied hydrogen storage systems produced for on-road vehicle service shall be capable of satisfying requirements of this Annexure. The manufacturer shall specify a maximum allowable working pressure (MAWP) for the inner container. The test elements within these performance requirements are summarized in below Table. These criteria apply to qualification of storage systems for use in new vehicle production. They do not apply to re-qualification of any single produced system for use beyond its expected useful service or re-qualification after a potentially significant damaging event.

**Table 1**

**Overview of Performance Requirements**

- 1.1.1 Verification tests for baseline metrics

- 1.1.1.1 Proof pressure
- 1.1.1.2 Baseline initial burst pressure
- 1.1.1.3 Baseline initial pressure cycle life
- 1.1.2 Verification test for expected on-road performance
  - 1.1.2.1 Boil Off
  - 1.1.2.2 Leak
  - 1.1.2.3 Vacuum loss
- 1.1.3 Verification test for service terminating performance in fire
- 1.1.4 Verification of components
  - 1.1.1 Verification of Baseline Metrics

#### 1.1.1.1 **Proof Pressure**

A system is pressurised to a pressure  $p_{\text{test}} \geq 1.3$  (MAWP  $\pm$  0.1MPa) in accordance with test procedure Paragraph 1.3.1.1. without visible deformation, degradation of container pressure, or detectable leakage.

#### 1.1.1.2 **Baseline Initial Burst Pressure**

The burst test is performed per the test procedure in Paragraph 1.3.1.2. on one sample of the inner container that is not integrated in its outer jacket and not insulated. The burst pressure shall be at least equal to the burst pressure used for the mechanical calculations. For steel containers that is either:

- (a) Maximum allowable working pressure (MAWP) (in MPa) plus 0.1MPa multiplied by 3.25; or
- (b) Maximum allowable working pressure (MAWP) (in MPa) plus 0.1MPa multiplied by 1.5 and multiplied by  $R_m/R_p$ , where  $R_m$  is the minimum ultimate tensile strength of the container material and  $R_p$  (minimum yield strength) is 1.0 for austenitic steels and  $R_p$  is 0.2 for other steels.

#### 1.1.1.3 **Baseline Pressure Cycle Life**

When using metallic containers and/or metallic vacuum jackets, the manufacturer shall either provide a calculation in order to demonstrate that the container is designed according to current regional legislation or accepted standards (e.g. in US the ASME Boiler and Pressure Vessel Code, in Europe EN 1251-1 and EN 1251-2 and in all other countries an applicable Standard for the design of metallic pressure containers), or define and perform suitable tests (including Paragraph 1.3.1.3.) that prove the same level of safety compared to a design supported by calculation according to accepted standards.

For non-metallic containers and/or vacuum jackets, in addition to Paragraph

1.3.1.3. testing, suitable tests shall be designed by the manufacturer to prove the same level of safety compared to a metallic container.

## 1.1.2 **Verification for Expected On-road Performance**

### 1.1.2.1 **Boil-off**

The boil-off test is performed on a liquefied hydrogen storage system equipped with all components as described in Paragraph 1 of this Annexure. The test is performed on a system filled with liquid hydrogen per the test procedure in Paragraph 1.3.2.1. and shall demonstrate that the boil-off system limits the pressure in the inner storage container to below the maximum allowable working pressure.

### 1.1.2.2 **Leak**

After the boil-off test in Paragraph 1.3.2.1., the system is kept at boil-off pressure and the total discharge rate due to leakage shall be measured per the test procedure in Paragraph 1.3.2.2. The maximum allowable discharge from the hydrogen storage system is  $R \times 150\text{Nml/min}$  where  $R = (V_{\text{width}}+1) \times (V_{\text{height}}+0.5) \times (V_{\text{length}}+1)/30.4$  and  $V_{\text{width}}$ ,  $V_{\text{height}}$ ,  $V_{\text{length}}$  are the vehicle width, height, length (m), respectively.

### 1.1.2.3 **Vacuum Loss**

The vacuum loss test is performed on a liquefied hydrogen storage system equipped with all components as described in Paragraph 1 of this Annexure. The test is performed on a system filled with liquid hydrogen per the test procedure in Paragraph 1.3.2.3. and shall demonstrate that both primary and secondary pressure relief devices limit the pressure to the values specified in Paragraph 1.3.2.3. in case vacuum pressure is lost.

## 1.1.3 **Verification of Service-terminating Conditions: Bonfire**

At least one system shall demonstrate the working of the pressure relief devices and the absence of rupture under the following service-terminating conditions. Specifics of test procedures are provided in Paragraph 1.3.4.

A hydrogen storage system is filled to half-full liquid level and exposed to fire in accordance with test procedure of Paragraph 1.3.4. The pressure relief device(s) shall release the contained gas in a controlled manner without rupture.

For steel containers the test is passed when the requirements relating to the pressure limits for the pressure relief devices as described in Paragraph 1.3.4. are fulfilled. For other container materials, an equivalent level of safety shall be demonstrated

## 1.1.4 **Verification of Components**

The entire storage system does not have to be re-qualified (Paragraph 1.1.) if container shut-off devices and pressure relief devices are exchanged for equivalent components having comparable function, fittings, and

dimensions, and qualified for performance using the same qualification (Paragraph 1.1.4.1. and 1.1.4.2.) as the original components.

#### 1.1.4.1 **Pressure Relief Devices Qualification Requirements**

Design qualification testing shall be conducted on finished pressure relief devices which are representative of normal production. The pressure relief devices shall meet the following performance qualification requirements:

- (a) Pressure test (Paragraph 1.3.5.1. test procedure);
- (b) External leakage test (Paragraph 1.3.5.2. test procedure);
- (c) Operational test (Paragraph 1.3.5.4. test procedure);
- (d) Corrosion resistance test (Paragraph 1.3.5.5. test procedure);
- (e) Temperature cycle test (Paragraph 1.3.5.8. test procedure).

#### 1.1.4.2 **Shut-off Valves Qualification Requirements**

Design qualification testing shall be conducted on finished shut-off valves which are representative for normal production. The valve shall meet the following performance qualification requirements:

- (a) Pressure test (Paragraph 1.3.5.1. test procedure);
- (b) External leakage Test (Paragraph 1.3.5.2. test procedure);
- (c) Endurance test (Paragraph 1.3.5.3. test procedure);
- (d) Corrosion resistance test (Paragraph 1.3.5.5. test procedure);
- (e) Resistance to dry-heat test (Paragraph 1.3.5.6. test procedure);
- (f) Ozone ageing test (Paragraph 1.3.5.7. test procedure);
- (g) Temperature cycle test (Paragraph 1.3.5.8. test procedure);
- (h) Flex line cycle test (Paragraph 1.3.5.9. test procedure).

#### 1.1.5 **Labelling**

A label shall be permanently affixed on each container with at least the following information: Name of the Manufacturer, Serial Number, Date of Manufacture, MAWP, Type of Fuel. Any label affixed to the container in compliance with this section shall remain in place. Test agencies may specify additional labelling requirements.

#### 1.2 **LHSS Fuel System Integrity**

This section specifies requirements for the integrity of the hydrogen fuel delivery system, which includes the liquefied hydrogen storage system, piping, joints, and components in which hydrogen is present. These

requirements are in addition to requirements specified in Part III of this Standard. The fuelling receptacle label shall designate liquid hydrogen as the fuel type. Test procedures are given in Paragraph 1.4.

1.2.1 Flammable materials used in the vehicle shall be protected from liquefied air that may condense on elements of the fuel system

1.2.2 The insulation of the components shall prevent liquefaction of the air in contact with the outer surfaces, unless a system is provided for collecting and vaporizing the liquefied air. The materials of the components nearby shall be compatible with an atmosphere enriched with oxygen.

### 1.3 Test Procedures for LHSS Design Qualification

#### 1.3.1 Verification Tests for Baseline Metrics

##### 1.3.1.1 Proof Pressure Test

The inner container and the pipe work situated between the inner container and the outer jacket shall withstand an inner pressure test at room temperature according to the following requirements.

The test pressure  $p_{\text{test}}$  is defined by the manufacturer and shall fulfil the following requirements:

$$p_{\text{test}} \geq 1.3 (\text{MAWP} \pm 0.1 \text{MPa})$$

(a) For metallic containers, either  $p_{\text{test}}$  is equal to or greater than the maximum pressure of the inner container during fault management (as determined in Paragraph 1.3.2.3.) or the manufacturer proves by calculation that at the maximum pressure of the inner container during fault management no yield occurs;

(b) For non-metallic containers,  $p_{\text{test}}$  is equal to or greater than the maximum pressure of the inner container during fault management (as determined in Paragraph 1.3.2.3.)

The test is conducted according to the following procedure:

(a) The test is conducted on the inner storage container and the interconnecting pipes between inner storage container and vacuum jacket before the outer jacket is mounted;

(b) The test is either conducted hydraulically with water or a glycol/water mixture, or alternatively with gas. The container is pressurised to test pressure  $p_{\text{test}}$  at an even rate and kept at that pressure for at least 10min;

(c) The test is done at ambient temperature. In the case of using gas to pressurize the container, the pressurisation is done in a way that the container temperature stays at or around ambient temperature.

The test is passed successfully if, during the first 10min after applying the proof pressure, no visible permanent deformation, no visible degradation in

the container pressure and no visible leakage are detectable.

#### 1.3.1.2 **Baseline Initial Burst Pressure**

The test is conducted according to the following procedure:

- (a) The test is conducted on the inner container at ambient temperature;
- (b) The test is conducted hydraulically with water or a water/glycol mixture;
- (c) The pressure is increased at a constant rate, not exceeding 0.5MPa/min until burst or leakage of the container occurs;
- (d) When MAWP is reached there is a wait period of at least ten minutes at constant pressure, during which time the deformation of the container can be checked;
- (e) The pressure is recorded or written during the entire test.

For steel inner containers, the test is passed successfully if at least one of the two passing criteria described in 7.4 of Part 3 of this Standard is fulfilled. For inner containers made out of an aluminium alloy or other material, a passing criterion shall be defined which guarantees at least the same level of safety compared to steel inner containers.

#### 1.3.1.3 **Baseline Pressure Cycle Life**

Containers and/or vacuum jackets are pressure cycled with a number of cycles at least three times the number of possible full pressure cycles (from the lowest to highest operating pressure) for an expected on-road performance. The number of pressure cycles is defined by the manufacturer under consideration of operating pressure range, size of the storage and, respectively, maximum number of refuellings and maximum number of pressure cycles under extreme usage and storage conditions. Pressure cycling is conducted between atmospheric pressure and MAWP at liquid nitrogen temperatures, e.g. by filling the container with liquid nitrogen to certain level and alternately pressurising and depressurising it with (pre-cooled) gaseous nitrogen or helium.

### 1.3.2 **Verification for Expected On-road Performance**

#### 1.3.2.1 **Boil-off Test**

The test is conducted according to the following procedure:

- (a) For pre-conditioning, the container is fuelled with liquid hydrogen to the specified maximum filling level. Hydrogen is subsequently extracted until it meets half filling level, and the system is allowed to completely cool down for at least 24h and a maximum of 48h;
- (b) The container is filled to the specified maximum filling level;
- (c) The container is pressurised until boil-off pressure is reached;

- (d) The test lasts for at least another 48h after boil-off started and is not terminated before the pressure stabilises. Pressure stabilization has occurred when the average pressure does not increase over a 2h period.

The pressure of the inner container is recorded or written during the entire test. The test is passed successfully if the following requirements are fulfilled:

- (a) The pressure stabilises and stays below MAWP during the whole test;
- (b) The pressure relief devices are not allowed to open during the whole test.

The pressure of the inner container shall be recorded or written during the entire test. The test is passed when the following requirements are fulfilled:

- (a) The pressure shall stabilise and stay below MAWP during the whole test;
- (b) The pressure relief devices are not allowed to open during the whole test.

#### 1.3.2.2 **Leak test**

The test shall be conducted according to the procedure described in Paragraph 1.3.5.2

#### 1.3.2.3 **Vacuum Loss Test**

The first part of the test is conducted according to the following procedure:

- (a) The vacuum loss test is conducted with a completely cooled-down container (according to the procedure in Paragraph 1.3.3.1.);
- (b) The container is filled with liquid hydrogen to the specified maximum filling level;
- (c) The vacuum enclosure is flooded with air at an even rate to atmospheric pressure;
- (d) The test is terminated when the first pressure relief device does not open any more.

The pressure of the inner container and the vacuum jacket is recorded or written during the entire test. The opening pressure of the first safety device is recorded or written. The first part of test is passed if the following requirements are fulfilled:

- (a) The first pressure relief device opens below or at MAWP and limit the pressure to not more than 110% of the MAWP;
- (b) The first pressure relief device does not open at pressure above MAWP;

(c) The secondary pressure relief device does not open during the entire test.

After passing the first part, the test shall be repeated subsequently to regeneration of the vacuum and cool-down of the container as described above.

- (a) The vacuum is re-generated to a value specified by the manufacturer. The vacuum shall be maintained at least 24h. The vacuum pump may stay connected until the time directly before the start of the vacuum loss;
- (b) The second part of the vacuum loss test is conducted with a completely cooled-down container (according to the procedure in Paragraph 1.3.3.1.);
- (c) The container is filled to the specified maximum filling level;
- (d) The line downstream the first safety relief device is blocked and the vacuum enclosure is flooded with air at an even rate to atmospheric pressure;
- (e) The test is terminated when the second pressure relief device does not open any more.

The pressure of the inner container and the vacuum jacket is recorded or written during the entire test. For steel containers the second part of the test is passed if the second pressure relief device does not open below 110% of the set pressure of the first safety relief device and limits the pressure in the container to a maximum 136% of the MAWP if a safety valve is used, or, 150% of the MAWP if a burst disk is used as the second safety relief device. For other container materials, an equivalent level of safety shall be demonstrated.

### 1.3.3 **Verification for Expected On-road Performance**

#### 1.3.3.1 **Boil-off Test**

The test is conducted according to the following procedure:

- (a) For pre-conditioning, the container is fuelled with liquid hydrogen to the specified maximum filling level. Hydrogen is subsequently extracted until it meets half filling level, and the system is allowed to completely cool down for at least 24h and a maximum of 48h;
- (b) The container is filled to the specified maximum filling level;
- (c) The container is pressurised until boil-off pressure is reached;
- (d) The test lasts for at least another 48h after boil-off started and is not terminated before the pressure stabilises. Pressure stabilization has occurred when the average pressure does not increase over a 2h period.

The pressure of the inner container is recorded or written during the entire test.

The test is passed successfully if the following requirements are fulfilled:

- (a) The pressure stabilises and stays below MAWP during the whole test;
- (b) The pressure relief devices are not allowed to open during the whole test.

The pressure of the inner container shall be recorded or written during the entire test. The test is passed when the following requirements are fulfilled:

- (a) The pressure shall stabilise and stay below MAWP during the whole test;
- (b) The pressure relief devices are not allowed to open during the whole test.

### 1.3.3.2 **Leak Test**

The test shall be conducted according to the procedure described in Paragraph 1.3.5.2.

### 1.3.3.3 **Vacuum Loss Test**

The first part of the test is conducted according to the following procedure:

- (a) The vacuum loss test is conducted with a completely cooled-down container (according to the procedure in Paragraph 1.3.3.1.);
- (b) The container is filled with liquid hydrogen to the specified maximum filling level;
- (c) The vacuum enclosure is flooded with air at an even rate to atmospheric pressure;
- (d) The test is terminated when the first pressure relief device does not open any more.

The pressure of the inner container and the vacuum jacket is recorded or written during the entire test. The opening pressure of the first safety device is recorded or written. The first part of test is passed if the following requirements are fulfilled:

- (a) The first pressure relief device opens below or at MAWP and limit the pressure to not more than 110% of the MAWP;
- (b) The first pressure relief device does not open at pressure above MAWP;
- (c) The secondary pressure relief device does not open during the entire test.

After passing the first part, the test shall be repeated subsequently to regeneration of the vacuum and cool-down of the container as described above.

- (a) The vacuum is re-generated to a value specified by the manufacturer. The vacuum shall be maintained at least 24h. The vacuum pump may stay connected until the time directly before the start of the vacuum loss;
- (b) The second part of the vacuum loss test is conducted with a completely cooled-down container (according to the procedure in Paragraph 1.3.3.1.);
- (c) The container is filled to the specified maximum filling level;
- (d) The line downstream the first safety relief device is blocked and the vacuum enclosure is flooded with air at an even rate to atmospheric pressure;
- (e) The test is terminated when the second pressure relief device does not open any more.

The pressure of the inner container and the vacuum jacket is recorded or written during the entire test. For steel containers the second part of the test is passed if the second pressure relief device does not open below 110% of the set pressure of the first safety relief device and limits the pressure in the container to a maximum 136% of the MAWP if a safety valve is used, or, 150% of the MAWP if a burst disk is used as the second safety relief device. For other container materials, an equivalent level of safety shall be demonstrated.

#### **1.3.4 Verification Test for Service-terminating Performance Due to Fire**

The tested liquefied hydrogen storage system shall be representative of the design and the manufacturing of the type to be homologated. Its manufacturing shall be completely finished and it shall be mounted with all its equipment.

The first part of the test is conducted according to the following procedure:

- (a) The bonfire test is conducted with a completely cooled-down container (according to the procedure in Paragraph 1.3.3.1.);
- (b) The container contained during the previous 24h a volume of liquid hydrogen at least equal to half of the water volume of the inner container;
- (c) The container is filled with liquid hydrogen so that the quantity of liquid hydrogen measured by the mass measurement system is half of the maximum allowed quantity that may be contained in the inner container;
- (d) A fire burns 0.1m underneath the container. The length and the width of the fire exceed the plan dimensions of the container by 0.1m. The temperature of the fire is at least 590°C. The fire shall continue to burn for the duration of the test;
- (e) The pressure of the container at the beginning of the test is between

0MPa and 0.01MPa at the boiling point of hydrogen in the inner container;

- (f) The test shall continue until the storage pressure decreases to or below the pressure at the beginning of the test, or alternatively in case the first PRD is a re-closing type, the test shall continue until the safety device has opened for a second time;
- (g) The test conditions and the maximum pressure reached within the container during the test are recorded in a test certificate signed by the manufacturer and the technical service. The test is passed if the following requirements are fulfilled:
  - (a) The secondary pressure relief device is not operated below 110% of the set pressure of the primary pressure relief device;
  - (b) The container shall not burst and the pressure inside the inner container shall not exceed the permissible fault range of the inner container.

The permissible fault range for steel containers is as follows:

- (a) If a safety valve is used as secondary pressure relief device, the pressure inside the container does not exceed 136% of the MAWP of the inner container;
- (b) If a burst disk is used outside the vacuum area as secondary pressure relief device, the pressure inside the container is limited to 150% of the MAWP of the inner container;
- (c) If a burst disk is used inside the vacuum area as secondary pressure relief device, the pressure inside the container is limited to 150% of the Maximum Allowable Working Pressure plus 0.1MPa (MAWP  $\pm$  0.1MPa) of the inner container.

For other materials, an equivalent level of safety shall be demonstrated.

### 1.3.5 **Component Verification Tests**

Testing shall be performed with hydrogen gas having gas quality compliant with ISO 14687-2/SAE J2719. All tests shall be performed at ambient temperature 20 ( $\pm$ 5) °C unless otherwise specified. The TPRD qualification performance tests are specified as follows:

#### 1.3.5.1 **Pressure Test**

A hydrogen containing component shall withstand without any visible evidence of leak or deformation a test pressure of 150% MAWP with the outlets of the high-pressure part plugged. The pressure shall subsequently be increased from 150% to 300% MAWP. The component shall not show any visible evidence of rupture or cracks.

The pressure supply system shall be equipped with a positive shut-off valve and a pressure gauge having a pressure range of not less than 150% and no

more than 200% of the test pressure; the accuracy of the gauge shall be 1% of the pressure range. Pressure gauge provision is optional if vehicle is provided with Fuel Level Indicator

For components requiring a leakage test, this test shall be performed prior to the pressure test.

#### 1.3.5.2 External Leakage Test

A component shall be free from leakage through stem or body seals or other joints, and shall not show evidence of porosity in casting when tested as described in Paragraph 1.3.5.3.3. at any gas pressure between zero and its MAWP.

The test shall be performed on the same equipment at the following conditions:

- (a) At ambient temperature;
- (b) At the minimum operating temperature or at liquid nitrogen temperature after sufficient conditioning time at this temperature to ensure thermal stability;
- (c) At the maximum operating temperature after sufficient conditioning time at this temperature to ensure thermal stability.

During this test, the equipment under test shall be connected to a source of gas pressure. A positive shut-off valve and a pressure gauge having a pressure range of not less than 150% and not more than 200% of the test pressure shall be installed in the pressure supply piping; the accuracy of the gauge shall be 1% of the pressure range. The pressure gauge shall be installed between the positive shut-off valve and the sample under test. Pressure gauge provision is optional if vehicle is provided with Fuel Level Indicator

Throughout the test, the sample shall be tested for leakage, with a surface-active agent without formation of bubbles or measured with a leakage rate less than 216Nml/hour

#### 1.3.5.3 Endurance Test

- 1.3.5.3.1 A component shall be capable of conforming to the applicable leakage test requirements of Paragraph 1.3.5.2. and 1.3.5.9., after being subjected to 20,000 operation cycles.
- 1.3.5.3.2 The appropriate tests for external leakage and seat leakage, as described in Paragraph 1.3.5.2. and 1.3.5.9 shall be carried out immediately following the endurance test.
- 1.3.5.3.3 The shut-off valve shall be securely connected to a pressurised source of dry air or nitrogen and subjected to 20,000 operation cycles. A cycle shall consist of one opening and one closing of the component within a period of not less than  $10 \pm 2$ s

- 1.3.5.3.4 The component shall be operated through 96% of the number of specified cycles at ambient temperature and at the MAWP of the component. During the off cycle the downstream pressure of the test fixture shall be allowed to decay to 50% of the MAWP of the component.
- 1.3.5.3.5 The component shall be operated through 2% of the total cycles at the maximum material temperature (-40°C to +85°C) after sufficient conditioning time at this temperature to ensure thermal stability and at MAWP. The component shall comply with Paragraph 1.3.5.2. and 1.3.5.9. at the appropriate maximum material temperature (-40°C to +85°C) at the completion of the high temperature cycles.
- 1.3.5.3.6 The component shall be operated through 2% of the total cycles at the minimum material temperature (-40°C to +85°C) but not less than the temperature of liquid nitrogen after sufficient conditioning time at this temperature to ensure thermal stability and at the MAWP of the component. The component shall comply with Paragraph 1.3.5.2. and 1.3.5.9. at the appropriate minimum material temperature (-40°C to +85°C) at the completion of the low temperature cycles.

1.3.5.4 **Operational Test**

The operational test shall be carried out in accordance with EN 13648-1 or EN 13648 2. The specific requirements of the standard are applicable

1.3.5.5 **Corrosion Resistance Test**

Metallic hydrogen components shall comply with the leakage tests referred to Paragraph 1.3.5.2. and 1.3.5.9. after being submitted to 144h salt spray test according to ISO 9227 with all connections closed.

A copper or brass hydrogen containing component shall comply with the leakage tests referred to Paragraph 1.3.5.2. and 1.3.5.9. and after being submitted to 24h immersion in ammonia according to ISO 6957 with all connections closed.

1.3.5.6 **Resistance to Dry-heat Test**

The test shall be carried out in compliance with ISO 188. The test piece shall be exposed to air at a temperature equal to the maximum operating temperature for 168h. The change in tensile strength shall not exceed  $\pm 25\%$ . The change in ultimate elongation shall not exceed the following values:

Maximum increase 10%,

Maximum decrease 30%.

1.3.5.7 **Ozone Ageing Test**

The test shall be in compliance with ISO 1431-1. The test piece, which shall be stressed to 20% elongation, shall be exposed to air at +40°C with an ozone concentration of 50 parts per hundred million during 120h.

No cracking of the test piece is allowed.

#### 1.3.5.8 **Temperature Cycle Test**

A non-metallic part containing hydrogen shall comply with the leakage tests referred to in Paragraph 1.3.5.2. and 1.3.5.9. after having been submitted to a 96h temperature cycle from the minimum operating temperature up to the maximum operating temperature with a cycle time of 120mins, under MAWP.

#### 1.3.5.9 **Flex Line Cycle Test**

Any flexible fuel line shall be capable of conforming to the applicable leakage test requirements referred to in Paragraph 1.3.5.2., after being subjected to 6,000 pressure cycles.

The pressure shall change from atmospheric pressure to the MAWP of the container within less than five seconds, and after a time of at least five seconds, shall decrease to atmospheric pressure within less than five seconds.

The appropriate test for external leakage, as referred to in Paragraph 1.3.5.2, shall be carried out immediately following the endurance test.

### 1.4 **Test Procedures for LHSS Fuel System Integrity**

#### 1.4.1 **Post-crash Leak Test for the Liquefied Hydrogen Storage Systems**

Prior to the vehicle crash test, the following steps are taken to prepare the liquefied hydrogen storage system (LHSS):

- (a) If the vehicle does not already have the following capabilities as part of the standard vehicle, and tests in Paragraph 1 of Annex IV. are to be performed; the following shall be installed before the test:
  - (i) LHSS pressure sensor. The pressure sensor shall have a full scale of reading of at least 150% of MAWP, an accuracy of at least 1% of full scale, and capable of reading values of at least 10kPa;
  - (ii) LHSS temperature sensor. The temperature sensor shall be capable of measuring cryogenic temperatures expected before crash. The sensor is located on an outlet, as near as possible to the container;
  - (iii) Fill and drain ports. The ability to add and remove both liquefied and gaseous contents of the LHSS before and after the crash test shall be provided.
- (b) The LHSS is purged with at least 5 volumes of nitrogen gas;
- (c) The LHSS is filled with nitrogen to the equivalence of the maximum fill level of hydrogen by weight;
- (d) After fill, the (nitrogen) gas vent is to be closed, and the container allowed to equilibrate;

(e) The leak-tightness of the LHSS is confirmed.

After the LHSS pressure and temperature sensors indicate that the system has cooled and equilibrated, the vehicle shall be crashed per state or regional Standard.

Following the crash, there shall be no visible leak of cold nitrogen gas or liquid for a period of at least 1h after the crash. Additionally, the operability of the pressure controls or PRDs shall be proven to ensure that the LHSS is protected against burst after the crash. If the LHSS vacuum has not been compromised by the crash, nitrogen gas may be added to the LHSS via the fill/drain port until pressure controls and/or PRDs are activated. In the case of re-closing pressure controls or PRDs, activation and re-closing for at least 2 cycles shall be demonstrated. Exhaust from the venting of the pressure controls or the PRDs shall not be vented to the passenger, luggage, or cargo compartments during these post-crash tests.

Following confirmation that the pressure control and/or safety relief valves are still functional, a leak test shall be conducted on the LHSS using the procedures in either Paragraph 1.1. or Paragraph 1.2 of Annex IV

Either test procedure Paragraph 1.4.1.1. or the alternative test procedure Paragraph 1.4.1.2. (consisting of Paragraph 1.4.1.2.1. and 1.4.1.2.2.) may be undertaken to satisfy test procedure Paragraph 1.4.1.

#### 1.4.1.1 **Post-crash Leak Test for the Liquefied Hydrogen Storage Systems (LHSSs)**

The following test would replace both the leak test in Paragraph 1.4.1.2.1. and gas concentration measurements as defined in Paragraph 1.4.1.2.2. Following confirmation that the pressure control and/or safety relief valves are still functional; the leak tightness of the LHSS may be proven by detecting all possible leaking parts with a sniff sensor of a calibrated Helium leak test device used in sniff modus. The test can be performed as an alternative if the following pre-conditions are fulfilled:

- (a) No possible leaking part shall be below the liquid nitrogen level on the storage container;
- (b) All possible leaking parts are pressurised with helium gas when the LHSS is pressurised;
- (c) Required covers and/or body panels and parts can be removed to gain access to all potential leak sites.

Prior to the test the manufacturer shall provide a list of all possible leaking parts of the LHSS. Possible leaking parts are:

- (a) Any connectors between pipes and between pipes and the container;
- (b) Any welding of pipes and components downstream the container;
- (c) Valves;

(d) Flexible lines;

(e) Sensors.

Prior to the leak test overpressure in the LHSS should be released to atmospheric pressure and afterwards the LHSS should be pressurised with helium to at least the operating pressure but well below the normal pressure control setting (so the pressure regulators do not activate during the test period). The test is passed if the total leakage amount (i.e. the sum of all detected leakage points) is less than 216 Nml/hr.

1.4.1.2 Alternative post-crash tests for the liquefied hydrogen storage systems. Both tests of Paragraph 1.4.1.2.1. and 1.4.1.2.2. are conducted under the test procedure of Paragraph 1.4.1.2.

1.4.1.2.1 **Alternative Post-crash Leak Test**

Following confirmation that the pressure control and/or safety relief valves are still functional, the following test may be conducted to measure the post-crash leakage. The concentration test in Paragraph 1.1 of Annex IV shall be conducted in parallel for the 60min test period if the hydrogen concentration has not already been directly measured following the vehicle crash.

The container shall be vented to atmospheric pressure and the liquefied contents of the container shall be removed and the container shall be heated up to ambient temperature. The heat-up could be done, e.g. by purging the container sufficient times with warm nitrogen or increasing the vacuum pressure.

If the pressure control set point is less than 90% of the MAWP, the pressure control shall be disabled so that it does not activate and vent gas during the leak test.

The container shall then be purged with helium by either:

- (a) Flowing at least 5 volumes through the container; or
- (b) Pressurising and de-pressurising the container the LHSS at least 5 times

The LHSS shall then be filled with helium to 80% of the MAWP of the container or to within 10% of the primary relief valve setting, whichever results in the lower pressure, and held for a period of 60 minutes. The measured pressure loss over the 60min test period shall be less than or equal to the following criterion based on the liquid capacity of the LHSS:

- (a) 2atm allowable loss for 100L systems or less;
- (b) 1atm allowable loss for systems greater than 100L and less than or equal to 200L; and
- (c) 0.5atm allowable for systems greater than 200L.

1.4.1.2.2 **Post-crash Enclosed Spaces Test**

The measurements shall be recorded in the crash test that evaluates potential liquid hydrogen leakage in test procedure Paragraph 1.4.1.2.1. if the LHSS contains hydrogen for the crash test or during the helium leak test in test procedure Paragraph 2 of Annex IV.

Select sensors to measure the build-up of hydrogen or helium depending which is contained within the Liquefied Hydrogen Storage Systems (LHSSs) for the crash test. Sensors may either measure the hydrogen/helium content of the atmosphere within the compartments or the reduction in oxygen due to displacement of air by leaking hydrogen/helium.

The sensors shall be calibrated to traceable references, have an accuracy of 5% of reading at the targeted criteria of 4% hydrogen (for a test with liquefied hydrogen) or 0.8% helium by volume in the air (for a test at room temperature with helium), and a full scale measurement capability of at least 25% above the target criteria. The sensor shall be capable of a 90% response to a full scale change in concentration within 10s.

The installation in vehicles with LHSSs shall meet the same requirements as for vehicles with compressed gaseous hydrogen storage systems in Paragraph 2 of Annex IV. Data from the sensors shall be collected at least every 5s and continue for a period of 60min after the vehicle comes to a rest if post-crash hydrogen is being measured or after the initiation of the helium leak test if helium build-up is being measured. Up to a 5s rolling average may be applied to the measurements to provide "smoothing" and filter effects of spurious data points. The rolling average of each sensor shall be below the targeted criteria of 4% hydrogen (for a test with liquefied hydrogen) or 0.8% helium by volume in the air (for a test at room temperature with helium) at all times throughout the 60min post-crash test period.

## ANNEXURE IX

**Reference Standards:**

Considerable assistance has been taken from following International and national standards in preparation of this standard.

1.	AIS 157	Safety & Procedural requirements for type approval of compressed gaseous hydrogen fuel cell vehicles
2.	(EU) 2021/535	Type-approval of vehicles, and of systems, components and separate technical units intended for such vehicles, as regards their general construction characteristics and safety
3.	ISO 17268	Gaseous hydrogen land vehicle refuelling connection device.
4.	ECE R 134	Approval of vehicles and their components with regard to safety related performance of Hydrogen fuelled vehicles
5.	GTR 13	Hydrogen & Fuel cell vehicles

## ANNEXURE-X

## (See Introduction) Composition of AISC Panel\*

SR. No.	NAME	ORGANISATION
1.	Dr. S. S. Thipse	ARAI
2.	Dr. A. V. Marathe	ARAI
3.	Dr. Kishorkumar P. Kavathekar	ARAI
4.	Mr. Sandeep D Rairikar	ARAI
5.	Mr. Ajay Dekate	ARAI
6.	Mr. Kamalesh B. Patil	ARAI
7.	Mr. Muthukumar N.	SIAM (Ashok Leyland Ltd.)
8.	Mr. V. Faustino	SIAM (Ashok Leyland Ltd.)
9.	Mr. Abhay Kumar	SIAM (Hero Moto. Corp. Ltd.)
10.	Mr. Karan Rajput	SIAM (Honda Motorcycle & Scooter India Pvt. Ltd.)
11.	Mr. Hari Sai Krishna	SIAM (Hyundai Motors India Ltd)
12.	Mr. Arun Kumar	SIAM (Mahindra & Mahindra Ltd.)
13.	Mr. Rajesh Kumar	SIAM (Maruti Suzuki India Ltd.)
14.	Mr. Lokesh Varma	SIAM (SKODA AUTO Volkswagen India Pvt. Ltd.)
15.	Shri P.S. Gowrishankar	SIAM (TATA Motors Ltd.)
16.	Shri Shailendra Dewangan	SIAM (TATA Motors Ltd.)
17.	Mr. Abhilash Savidhan	Reliance India Ltd.
18.	Mr. Mahadevan N	Reliance India Ltd.
19.	Mr. Fredrick A	Bosch India Ltd.
20.	Mr. Alok Kumar	Denso International India Pvt. Ltd.
21.	Dr. Shabana Shaikh	H2E Power
22.	Mr. Anupam Dave	ICEMA (JCB India Ltd.)
23.	Mr. Chaitanya Joshi	Praj Industries Limited.
24.	Mr. Hiwale Harshad	Swagelok
25.	Mr. Koulgi Sachin	Swagelok
26.	Mr. Hemant Joshi	Vanaz Eng. Limited
27.	Mr. Godase Sushil	---
28.	Mr. Dnyanesh	---

**ANNEXURE E**  
(See Introduction)

**COMMITTEE COMPOSITION \***  
**Automotive Industry Standards Committee**

<b>Chairperson</b>	
Dr. Reji Mathai	Director, The Automotive Research Association of India, Pune
<b>Members</b>	<b>Representing</b>
Representative from	Ministry of Road Transport and Highways, New Delhi
Representative from	Ministry of Heavy Industries, New Delhi
Representative from	Office of the Development Commissioner, MSME, Ministry of Micro, Small and Medium Enterprises, New Delhi
Shri Shrikant R. Marathe	Former Chairman, AISC
Shri P. V. Srikanth	Bureau of Indian Standards
Director	Central Institute of Road Transport
Director	Global Automotive Research Centre
Director	International Centre for Automotive Technology
Director	Indian Institute of Petroleum
Director	Vehicles Research and Development Establishment
Director	Indian Rubber Manufacturers Research Association
Representatives from	Society of Indian Automobile Manufacturers
Representative from	Tractor Manufacturers Association
Representative from	Automotive Components Manufacturers Association of India
Representative from	Indian Construction Equipment Manufacturers' Association (ICEMA)
Member Secretary	
Shri Vikram Tandon	The Automotive Research Association of India, Pune

\* At the time of approval of this Automotive Industry Standard (AIS)