

Amendment No 2 (02/2025)

To

AIS-174 Specific Requirements for Electric Power Train Construction Equipment Vehicles

1.0 Add following new clause 3.2 after clause 3.1

3.2 Measurement of noise level for electric power train construction Equipment vehicles*:

3.2.1 Determination of Sound Power Level – Stationary test condition shall be done as per ISO 6393:2008 except clause 7.2 and Determination of Emission Sound Pressure Level at Operator’s position–Stationary test condition as per ISO 6394:2004. Additionally, following provision shall be taken into consideration

The vehicle shall be operated at maximum motor RPM at full actuation of accelerator control as specified by the manufacturer in stationary condition.

3.2.2 Determination of Sound Power Level – Dynamic test condition shall be done as per ISO 6395:2008 & Determination of emission sound pressure level at operator's position — Dynamic test conditions as per ISO 6396:2008. Additionally, following provision shall be taken into consideration.

The vehicle shall be operated at maximum motor RPM at forward and reverse travel constant speed of vehicle at full actuation of accelerator control as specified by the manufacturer at 1st gear wherever applicable in dynamic condition.

3.2.3 Measurement of dynamic noise shall be done as per AIS-160 at maximum motor RPM at forward and reverse travel constant speed of vehicle at full actuation of accelerator control as specified by the manufacturer at 1st gear wherever applicable in dynamic condition.

If vehicle is provided with two motors, only corresponding motor during travel or stationary mode has to kept operational during measurement of noise, the auxiliary motor shall be kept off & vice versa.

* Refer Table 2 of GSR 673 (E) Dt. 27th Oct 2020 for Noise Limits for Pass by Noise Test at Static and Dynamic Conditions. In case of electric CEV, in the said notification words “Max power of engine” shall be read as “Max power for traction motor”

3.3 Horn & Reverse Alarm Noise shall be done as per IS/ISO 9533:2010. In this measurement maximum motor RPM shall be considered for engine RPM.

Maximum motor RPM shall be considered in place of engine RPM during noise measurement for Machine-mounted audible travel alarms and forward horns as per IS/ISO 9533:2010

- 3.4 Evaluation of brake performance shall be as per AIS 143 with regenerative braking system in off condition.
- 3.5 Every Electric CEV shall have tale tells for Battery SoC, Motor RPM and Battery malfunction* as per AIS-071 (Part 1)

*Battery Malfunction tale tell is mandatory only in case of Lithium Ion Battery. In case of lead acid battery, it is optional.

PRINTED BY
THE AUTOMOTIVE RESEARCH ASSOCIATION OF INDIA
P. B. NO. 832, PUNE 411 004

ON BEHALF OF
AUTOMOTIVE INDUSTRY STANDARDS COMMITTEE

UNDER
CENTRAL MOTOR VEHICLES RULES - TECHNICAL STANDING COMMITTEE

SET-UP BY
MINISTRY OF ROAD TRANSPORT & HIGHWAYS
(DEPARTMENT OF ROAD TRANSPORT & HIGHWAYS)
GOVERNMENT OF INDIA

20th February 2025

Amendment No. 1 (01/2025)
to
**AIS 174 Specific Requirements for Electric Power Train Construction
Equipment Vehicle(s)**

1.0 Page No 15/32 Clause No 8.2

Substitute following text for existing text:

Electro Magnetic Compatibility (EMC) tests shall be done on construction equipment vehicle as per IS / ISO 13766 (Part 1):2018, in configuration other than “REESS charging mode coupled to the power grid” (means construction equipment vehicle not in charging condition).

2.0 Page No 15/32 Clause No 8.3

Substitute following text for existing text:

Electric Construction Equipment Vehicle: Machinery state during test

EMC tests shall be done as per IS / ISO 13766 (Part 1):2018 standard. Electric Traction Motor of Construction Equipment Vehicle shall be at constant speed corresponding to three quarters of the maximum speed of the Electric Motor or 20 per cent to 80 per cent of maximum speed of Construction Equipment Vehicle, if there is no technical reason for the manufacturer to prefer another speed. The electric motor shall be appropriately loaded, if feasible. If need be, the transmission shafts may be disengaged, provided they do not drive a component-emitting interference.

3.0 Page No 15/32 Clause No 8.4

Substitute following text for existing text:

Hybrid Electric Construction Equipment Vehicle: Machinery state during test

For radiated emission test as per IS / ISO 13766 (Part 1):2018 standard, of Hybrid Electric Construction Equipment Vehicle shall be tested, over the specified frequency range with both the combustion engine and electric drive running, with constant speed corresponding to three quarters of its maximum speed of Construction Equipment Vehicle or with constant machine speed corresponding to 20 per cent to 80 per cent of maximum speed of Construction Equipment Vehicle , if there is no technical reason for the manufacturer to prefer another speed. The vehicle’s drive train shall be appropriately loaded, if feasible. If need be, the transmission shafts may be disengaged, provided they do not drive a component-emitting interference.

If the above condition is not possible, two separate tests shall be conducted as follows:

4.0 Page No 16/32 Clause No 8.4.1

Substitute following text for existing text:

Electric Motor Drive Mode:

Radiated emission test shall be conducted as per IS / ISO 13766 (Part 1):2018 standard, provided that a continuous power source may be supplied to the Rechargeable Energy Storage System (REESS) to keep the vehicle’s electric

motor running without starting the combustion engine, at maximum possible setting. Manufacturer may facilitate this through service mode.

5.0 Page No 16/32 Clause No 8.4.2

Substitute following text for existing text:

Engine Mode:

The test shall be conducted as per IS / ISO 13766 (Part 1):2018 standard, as applicable for engine type. Manufacturer may recommend energy storage level of REESS, such that combustion engine does not charge the REESS during the test.

6.0 Page No 16/32 Clause No 8.4.3

Substitute following text for existing text:

Radiated Immunity test shall be done as per IS / ISO 13766 (Part 1):2018 standard for Hybrid Electric Construction Equipment Vehicle at constant speed corresponding to three quarters of the maximum speed of electric motor and/or engine or at constant speed corresponding to 20 per cent to 80 per cent of maximum speed of Construction Equipment Vehicle, if there is no technical reason for the manufacturer to prefer another speed. The vehicle's drive train shall be appropriately loaded, if feasible. If need be, the transmission shafts may be disengaged, provided they do not drive a component-emitting interference.

PRINTED BY

THE AUTOMOTIVE RESEARCH ASSOCIATION OF INDIA

P. B. NO. 832, PUNE 411 004

ON BEHALF OF

AUTOMOTIVE INDUSTRY STANDARDS COMMITTEE

UNDER

CENTRAL MOTOR VEHICLES RULES - TECHNICAL STANDING COMMITTEE

SET-UP BY

MINISTRY OF ROAD TRANSPORT & HIGHWAYS

(DEPARTMENT OF ROAD TRANSPORT & HIGHWAYS)

GOVERNMENT OF INDIA

21st January 2025

AUTOMOTIVE INDUSTRY STANDARDS

**Specific Requirements for Electric Power
Train Construction Equipment Vehicle(s)**

PRINTED BY
THE AUTOMOTIVE RESEARCH ASSOCIATION OF INDIA
P.B. NO. 832, PUNE 411 004

ON BEHALF OF
AUTOMOTIVE INDUSTRY STANDARDS COMMITTEE

UNDER
CENTRAL MOTOR VEHICLE RULES – TECHNICAL STANDING COMMITTEE

SET-UP BY
MINISTRY OF ROAD TRANSPORT and HIGHWAYS
(DEPARTMENT OF ROAD TRANSPORT and HIGHWAYS)
GOVERNMENT OF INDIA

November 2022

INTRODUCTION

The Government of India felt the need for a permanent agency to expedite the publication of standards and development of test facilities in parallel when the work of preparation of standards is going on, as the development of improved safety critical parts can be undertaken only after the publication of the standard and commissioning of test facilities. To this end, the erstwhile Ministry of Surface Transport (MoST) has constituted a permanent Automotive Industry Standards Committee (AISC) vide order no. RT-11028/11/97-MVL dated September 15, 1997. The standards prepared by AISC will be approved by the permanent CMVR Technical Standing Committee (CTSC). After approval, The Automotive Research Association of India, (ARAI), Pune, being the secretariat of the AIS Committee, has published this standard. For better dissemination of this information, ARAI may publish this standard on their website.

Electric and hybrid power train are being used in Construction Equipment Vehicles also. This standard prescribes the specific requirements for Electric Power Train Construction Equipment Vehicles.

All other standards notified under CMVR for Construction Equipment Vehicles will be applicable. In addition to, this AIS standard will be applicable for Electric and Hybrid-Electric Power Train Construction Equipment Vehicles.

While preparing this standard considerable assistance is derived from following National/International Standards:

AIS 168	Specific Requirements for A6 and A7 Category Electric Power Train Agricultural Tractors.
AIS 156	Specific Requirements for L Category Electric Power Train Vehicles.
Commission Delegated Regulation (EU) No 3/2014 Of October 24, 2013	Supplementing Regulation (EU) No 168/2013 of the European Parliament and of the Council with regard to vehicle functional safety requirements for the approval of two- or three-wheel vehicles and quadricycles.
Regulation (EU) No 167/2013 of The European Parliament and of the Council of February 5, 2013	On the approval and market surveillance of agricultural and forestry vehicles.
Commission Delegated Regulation (EU) 2015/208 Of December 8, 2014	Supplementing Regulation (EU) No 167/2013 of the European Parliament and of the Council with regard to vehicle functional safety requirements for the approval of agricultural and forestry vehicles.

The AISC panel and the Automotive Industry Standards Committee (AISC) responsible for preparation of this standard are given in Annex 7 and Annex 8 respectively.

Contents

Para. No.	Items	Page No.
1	Scope	1/32
2	Definitions	1/32
3	Application for approval of Construction Equipment Vehicles	4/32
4	Application for approval of REESS	4/32
5	Requirements of a Construction Equipment Vehicle with regard to its electrical safety	5/32
6	Requirements of a Rechargeable Electrical Energy Storage System (REESS) with regard to its safety	14/32
7	Traction Motor Power Test	14/32
8	EMC Test	15/32
9	Criteria for Extension of Approval	16/32
10	Technical Specifications	16/32
List of Annexes		
Annex 1	Isolation resistance measurement method for vehicle based tests	17/32
Annex 2	Confirmation method for function of on-board isolation resistance monitoring system	21/32
Annex 3	Protection against direct contacts of parts under voltage	22/32
Annex 4	Hose Nozzle for the Test for Protection against Washing	25/32
Annex 5	Essential characteristics of Construction Equipment Vehicles	26/32
Annex 6	Essential characteristics of REESS	29/32
Annex 7	Composition of AISC Panel	31/32
Annex 8	Composition of AISC	32/32

Specific Requirements for Electric Power Train Construction Equipment Vehicles

1.0 SCOPE

- 1.1 This standard is applicable for electric power train Construction Equipment Vehicle (CEVs) as defined in CMVR “2”, sub rule “cab”.
- 1.2 This standard specifies the safety requirements with respect to the electric power train of Construction Equipment Vehicle (Hybrid electric CEVs and Pure electric CEVs).

2.0 DEFINITIONS

For the purpose of this standard following definitions shall apply. For additional applicable terms, refer AIS-049 (Rev 1), as amended from time to time, AIS-038 (Rev. 2), as amended from time to time, IS/ISO 6165 : 2012, as amended from time to time and IS 14272:2011, as amended from time to time.

- 2.1 **‘Active driving possible mode’** means the vehicle mode when application of the electric acceleration position sensor, activation of an equivalent control or release of the brake system will cause the electric powertrain to propel the vehicle;
- 2.2 **‘Barrier’** means the part providing protection against direct contact to the live parts from any direction of access;
- 2.3 **‘Conductive connection’** means the connection using connectors to an external power supply when the rechargeable electrical energy storage system (REESS) is charged;
- 2.4 **‘Coupling system for charging the REESS’** means the electrical circuit used for charging the REESS from an external electric power supply including the vehicle inlet;
- 2.5 **‘Chassis connected to the electric circuit’** means AC and DC electric circuits galvanically connected to the electrical chassis.
- 2.6 **‘Control’** means any part of the vehicle or component directly actuated by the driver which causes a change in the state or operation of the vehicle or one of the parts thereof;
- 2.7 **‘Direct contact’** means the contact of persons with live parts;
- 2.8 **‘Electrical chassis’** means a set made of conductive parts electrically linked together, whose potential is taken as reference;
- 2.9 **‘Electrical circuit’** means an assembly of connected live parts which is designed to be electrically energised in normal operation;

- 2.10 **‘Electric energy conversion system’** means a system that generates and provides electric energy for electric propulsion;
- 2.11 **‘Electric powertrain’** means the electrical circuit which includes the traction motor(s), and includes the REESS, the electric energy conversion system, the electronic converters, the associated wiring harness and connectors, and the coupling system for charging the REESS;
- 2.12 **‘Electronic converter’** means a device capable of controlling and / or converting electric power for electric propulsion;
- 2.13 **‘Enclosure’** means the part enclosing the internal units and providing protection against direct contact from any direction of access;
- 2.14 **‘Exposed conductive part’** means the conductive part which can be touched under the provisions of the protection degree IPXXB, and which becomes electrically energised under isolation failure conditions;
- 2.15 **‘External electric power supply’** means an alternating current (AC) or direct current (DC) electric power supply outside of the vehicle;
- 2.16 **‘High voltage’** means the classification of an electric component or circuit, if its working voltage is $> 60 \text{ V}$ and $\leq 1\,500 \text{ V DC}$ or $> 30 \text{ V}$ and $\leq 1\,000 \text{ V AC}$ root mean square (rms);
- 2.17 **‘High voltage bus’** means the electrical circuit, including the coupling system for charging the REESS that operates on high voltage;
- 2.18 **‘Indirect contact’** means the contact of persons with exposed conductive parts;
- 2.19 **‘Live parts’** means the conductive part(s) intended to be electrically energised in normal use;
- 2.20 **‘Operator’s work place’** –means the space in the Construction Equipment Vehicle for operator accommodation bounded by the barriers and enclosures provided for protecting the powertrain from direct contact with live parts;
- 2.21 **‘On-board isolation resistance monitoring system’** means the device which monitors the isolation resistance between the high voltage buses and the electrical chassis;
- 2.22 **‘Open type traction battery’** means a liquid type battery requiring refilling with water and generating hydrogen gas released to the atmosphere;
- 2.23 **‘Protection degree’** means the protection provided by a barrier or enclosure related to the contact with live parts by a test probe, such as a jointed test finger (IPXXB) or a test wire access probe (IPXXD);

- 2.24 **‘Service disconnect’** means the device for deactivation of the electrical circuit for the purpose of servicing or checking electrical components such as the REESS and fuel cell stack;
- 2.25 **‘Solid insulator’** means the insulation coating of wiring harnesses insulating live parts against direct contact from any direction of access, covers insulating live parts of connectors, as well as varnish or paint applied for the purpose of insulation;
- 2.26 **‘Working voltage’** means the highest value of an electrical circuit voltage root-mean-square (rms) as specified by the vehicle manufacturer for each separate and galvanically isolated circuit, which may occur between any conductive parts in open circuit conditions or under normal operating condition;
- 2.27 **‘Construction Equipment Vehicle type’** with regard to maximum continuous rated or net power and/or vehicle speed limitation by design’ means vehicles which do not differ in such essential respects as the maximum continuous power output of the electric motor(s) and/or engine, the vehicle maximum design speed and the design characteristics of devices and methodology employed to effectively limit the vehicle’s achievable maximum speed and/or power output;
- 2.28 **‘Functional safety’** means the absence of unacceptable risk of physical injury or of damage to the health of persons or to property owing to hazards caused by mal-functional behaviour of mechanical, hydraulic, pneumatic, electrical or electronic systems, components or separate technical units;
- 2.29 **‘REESS’** means the **rechargeable electric energy storage system (REESS)** that provides energy for electric propulsion;
- 2.30 **"State of Charge (SOC)"** means the available electrical charge in a tested-device expressed as a percentage of its rated capacity.
- 2.31 **‘Type of Construction Equipment Vehicle with regard to electrical safety’** means vehicles which do not differ in such essential respects as the location of conducting parts and components of the entire electrical system installed in the vehicle, the installation of the electric powertrain and the galvanically connected high voltage bus as well as the nature and type of electric powertrain and the galvanically connected high voltage components;
- 2.32 **"Type of REESS"** means systems which do not differ significantly in such essential aspects as:
- (a) The manufacturer's trade name or mark;
 - (b) The chemistry, capacity and physical dimensions of its cells;
 - (c) The number of cells, the mode of connection of the cells and the physical support of the cells;

- (d) The construction, materials and physical dimensions of the casing; and
- (e) The necessary ancillary devices for physical support, thermal management and electronic control.

2.33 'Driver' means an operator responsible for the movement of a machine. The driver may be transported by the machinery or may be on foot, accompanying the machinery, or may guide the machinery by remote control.

3.0 APPLICATION FOR APPROVAL OF CONSTRUCTION EQUIPMENT VEHICLE

3.1 Approval of Construction Equipment Vehicle type with regard to its electrical safety, including the High Voltage System

3.1.1. The application for approval of Construction Equipment Vehicles type with regard to specific requirements for the electric power train shall be submitted by the vehicle manufacturer or by his duly accredited representative.

3.1.2. It shall be accompanied by the technical specifications in AIS 007 (Rev. 5) format and following particulars in Annex 5 format:

3.1.2.1. Detailed description of the Construction Equipment Vehicles type as regards the electric power train and the galvanically connected high voltage bus.

3.1.2.2. For Construction Equipment Vehicles with REESS, additional evidence showing that the REESS is in compliance with the requirements of paragraph 6. of this Standard.

3.1.3. Construction Equipment Vehicles representative of the Construction Equipment Vehicle type to be approved shall be submitted to the Test Agency responsible for conducting the approval tests and, if applicable, at the manufacturer's discretion with the agreement of the Test Agency, either additional vehicle(s), or those parts of the vehicle regarded by the Test Agency as essential for the test(s) referred to in the paragraph 6. of this Standard.

4.0 APPLICATION FOR APPROVAL OF REESS

4.1 Approval of a Rechargeable Electrical Energy Storage System (REESS)

4.1.1. The application for approval of a type of REESS or separate technical unit with regard to the safety requirements of the REESS shall be submitted by the REESS manufacturer or by their duly accredited representative.

4.1.2. It shall be accompanied by the technical specifications in AIS 007 (Rev. 5) and Annex 6 format and comply with the following particulars:

- 4.1.2.1. Detailed description of the type of REESS or separate technical unit as regards the safety of the REESS.
- 4.1.3. A component(s) representative of the type of REESS to be approved plus, at the manufacturer's discretion, and with the agreement of the Test Agency, those parts of the Construction Equipment Vehicle regarded by the Test Agency as essential for the test, shall be submitted to the Test Agency responsible for conducting the approval tests.

5.0 REQUIREMENTS REGARDING ELECTRICAL SAFETY

5.1 Requirements for the approval of a type of Construction Equipment Vehicle with regard to electrical safety

- 5.1.1 Construction Equipment Vehicle which are propelled by means of one or more electric motors, including pure and hybrid electric Construction Equipment Vehicle, shall fulfil the requirements of this clause.

5.2 General requirements concerning the protection against electrical shock and electrical safety applying to high voltage buses under conditions where they are not connected to external high voltage power supplies.

- 5.2.1 The protection against direct contact with live parts shall comply with the requirements set out below. The protections provided (e.g. solid insulator, barrier, enclosure) shall not be able of being opened, disassembled or removed without the use of tools.

The protection against access to live parts shall be tested in accordance with the provisions laid down in Annex 3 of this standard — Protection against direct contacts of parts under voltage.

- 5.2.1.1 For protection of live parts in operator's work place, the protection degree IPXXD shall be met.
- 5.2.1.2 For protection of live parts in areas other than the operator's work place, the protection degree IPXXB shall be met.
- 5.2.1.3 For protection of live parts of vehicles where no operator's work place is present, the protection degree IPXXD shall be met by the entire vehicle.
- 5.2.1.4 Connectors (including vehicle inlet) are deemed to meet the requirements if:
- (a) They also comply with the protection degree IPXXB when separated without the use of tools;
 - (b) They are located underneath the vehicle floor and are provided with a locking mechanism (e.g. screw locking, bayonet locking);

- (c) They are provided with a locking mechanism and other components shall first be removed with the use of tools in order to separate the connector; or
 - (d) The voltage of the live parts becomes \leq DC 60 V or \leq AC 30 V (rms) within one second after the connector is separated.
- 5.2.1.5 In case a service disconnect can be opened, disassembled or removed without the use of tools, the protection degree IPXXB shall be met under all these conditions.
- 5.2.1.6 **Specific marking requirements**
- 5.2.1.6.1 In the case of a REESS having high voltage capability, the symbol shown in Figure 1 shall be placed on or near the REESS. The symbol background shall be yellow, the bordering and the arrow shall be black.

Figure 1

Marking of high voltage equipment

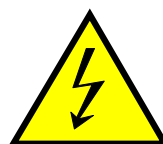

- 5.2.1.6.2 The symbol shall in addition be placed on all enclosures and barriers, which when removed expose live parts of high voltage circuits. This provision is optional for connectors for high voltage buses and does not apply to any of the following cases:
- (a) Where barriers or enclosures cannot be physically accessed, opened, or removed unless other vehicle components are removed with the use of tools; or
 - (b) Where barriers or enclosures are located underneath the vehicle floor.
- 5.2.1.6.3 Cables for high voltage buses, which are located fully within enclosures or outside any enclosures, shall be identified by having an outer covering with the colour orange.
- 5.2.2 **The protection against indirect contact with live parts shall comply with the requirements set out below.**
- 5.2.2.1 Concerning protection against electrical shock which could arise from indirect contact, the exposed conductive parts, such as the conductive barrier and enclosure, shall be securely galvanically connected to the electrical chassis for instance by connections with electrical wire, ground cable, welds or by connections using bolts so that no dangerous electric potential can exist.

5.2.2.2 The resistance between all exposed conductive parts and the electrical chassis shall be lower than 0.1Ω when there is current flow of at least 0.2 A. This requirement is deemed as satisfied if the galvanic connection has been established by welding.

5.2.2.3 In the case of vehicles intended to be connected to a grounded external electric power supply through a conductive connection, a device enabling the galvanic connection of the electrical chassis to the earth ground shall be provided.

The device shall enable connection to the earth ground before external voltage is supplied to the vehicle and shall retain this connection until after the exterior voltage is removed from the vehicle.

Compliance with these requirements may be demonstrated by using the connector specified by the construction equipment vehicle manufacturer or by other analysis.

5.2.2.3.1 A galvanic connection of the electrical chassis to the earth ground does not need to be provided in the following cases:

- (a) The construction equipment vehicle can only use a dedicated charger that is protected when any single isolation fault arises;
- (b) The construction equipment vehicle's whole metallic body is protected when any single isolation fault arises; or
- (c) The construction equipment vehicle cannot be charged without completely removing the traction battery pack from the vehicle.

5.2.2.4 The requirement of paragraph 5.2.2.3. above shall not apply to the vehicles which satisfy (a) or (b) below:

- (a) The vehicle's REESS can be charged via the external electric power supply only by using an off-board charger with a double insulation or reinforced insulation structure between input and output.

The performance requirements regarding the previously mentioned insulation structure shall comply with the following requirements of paragraph 5.2.2.4.1.

- (b) The on-board charger has a double or reinforced insulation structure between input and the vehicle's exposed conductive parts / electrical chassis.

The performance requirements regarding the previously mentioned insulation structure shall comply with the following requirements of paragraphs 5.2.2.4.2.

If both systems are installed (a) and (b) have to be fulfilled.

5.2.2.4.1 Insulation resistance test for DC External off-board charger

The insulation resistance shall be equal to or greater than 7 M Ω when applying 500 V DC between all the inputs of the charger (plug) connected together and the vehicle's exposed conductive parts including the electrical chassis if present.

5.2.2.4.2 Withstand voltage test and Insulation resistance test, for on-board (built-in) charger

Insulation resistance shall be measured after application of the test voltage to the vehicle with the on-board (built-in) charger.

The following testing procedure shall be applicable to vehicles with on-board (built-in) chargers:

Between all the inputs of the charger (plug) and the vehicle's exposed conductive parts including the electrical chassis if present, apply a AC test voltage of $2 \times (U_n + 1200)$ V rms at a frequency of 50 Hz or 60 Hz for one minute, where U_n is the AC input voltage (rms);

The test shall be performed on the complete vehicle;

All the electrical devices shall be connected.

Instead of the specified AC voltage, the DC voltage whose value is equivalent to the specified AC voltage's peak value may be applied for one minute.

After the test, measure the insulation resistance when applying 500 V D.C. between all the inputs and the vehicle's exposed conductive parts including the electrical chassis if present.

The insulation resistance shall be equal to or greater than 7 M Ω

5.2.3 Isolation resistance shall comply with the requirements set out below.**5.2.3.1 Concerning electric power trains consisting of separate DC or AC-buses:**

If AC buses and DC buses are galvanically isolated from each other, isolation resistance between all high voltage busses and the electrical chassis shall have a minimum value of 100 Ω /V of the working voltage for DC buses, and a minimum value of 500 Ω /V of the working voltage for AC buses.

The measurements shall be conducted in accordance with the provisions laid down in Annex 1 of this standard — Isolation resistance measurement method.

5.2.3.2 **Concerning electric power train consisting of combined DC- and AC-buses:**

If AC high voltage buses and DC high voltage buses are galvanically connected isolation resistance between all high voltage busses and the electrical chassis shall have a minimum value of 500 Ω/V of the working voltage.

However, if all AC high voltage buses are protected by one of the two following measures, isolation resistance between the high voltage bus and the electrical chassis shall have a minimum value of 100 Ω/V of the working voltage:

- (a) Double or more layers of solid insulators, barriers or enclosures that meet the requirements of points 5.2.1 to 5.2.1.6.3 independently, for example wiring harness; or
- (b) Mechanically robust protections that have sufficient durability over vehicle service life such as motor housings, electronic converter cases or connectors;

The isolation resistance between the high voltage bus and the electrical chassis shall be demonstrated by measurement.

The measurement shall be conducted according to Annex 1 of this standard - Isolation resistance measurement method.

5.2.3.3 **Concerning Fuel cell Construction Equipment Vehicles:**

If the minimum isolation resistance requirement cannot be maintained over time, then protection shall be achieved by any of the following:

- (a) Double or more layers of solid insulators, barriers or enclosures that meet the requirements of points 5.2.1 to 5.2.1.6.3 independently; or
- (b) on-board isolation resistance monitoring system together with a warning to the driver if the isolation resistance drops below the minimum required value. The isolation resistance between the high voltage bus of the coupling system for charging the REESS, which is not energized besides during charging the REESS, and the electrical chassis need not be monitored.

The correct functioning of the on-board isolation resistance monitoring system shall be tested as described in Annex 2 of this standard — Confirmation method for function of on-board isolation resistance monitoring system.

5.2.3.4 Isolation resistance requirements for the coupling system for charging the REESS.

The vehicle inlet or the recharge cable when permanently connected to the vehicle, intended to be conductively connected to the grounded external AC power supply and the electrical circuit that is galvanically connected to the vehicle inlet/recharge cable during charging of the REESS, shall have an isolation resistance between the high voltage bus and the electrical chassis of at least 1.0 MΩ when the charger coupler is disconnected. During the measurement, the traction battery may be disconnected.

5.3 **Requirements concerning the REESS**

5.3.1 **Protection in case of excessive current.**

The REESS shall not overheat in case of excessive current or, if the REESS is prone to overheating due to excessive current, it shall be equipped with one or more protective devices such as fuses, circuit breakers and/or main contactors.

When applicable, the construction equipment vehicle manufacturer shall supply relevant data and analysis proving that overheating from excessive current is prevented without the use of protective devices.

5.3.2 **Prevention of accumulation of gas.**

Places for containing open type traction battery that may produce hydrogen gas shall be provided with a ventilation fan or a ventilation duct or any other suitable means to prevent the accumulation of hydrogen gas. Vehicles with open type framework that do not allow accumulation of hydrogen gas at such places are not required to have a ventilation fan or a ventilation duct.

5.3.3 **Protection against electrolyte spills.**

Electrolyte from the REESS, shall not spill from the construction equipment vehicle in its normal operation and during all the tests as per this standard.

In case electrolyte is spilled from the REESS or its components due to other reasons, it shall not reach the driver nor any person on or around the construction equipment vehicle during normal conditions of use, parked condition (i.e. also when the construction equipment vehicle is parked on a slope) or any other normal functional operation.

5.3.4 **Accidental or unintentional detachment.**

The REESS and its components shall be installed in the construction equipment vehicle in such a way so as to preclude the possibility of inadvertent or unintentional detachment or ejection of the REESS.

The REESS and its components shall not be ejected when the construction equipment vehicle in its normal operation and any of the test as per this standard.

5.4 In-use safety requirements

5.4.1 Propulsion system/power-train power-on and power-off procedure

5.4.1.1 At the start-up, including system power-on, in order to select the active driving and/or operation possible mode, at least two deliberate and distinctive actions shall be performed by the driver/operator.

5.4.1.2 At least a momentary indication shall be given to the driver /operator when the construction equipment vehicle is switched in active driving and/or operation possible mode, however, this provision does not apply under conditions where an internal combustion engine provides directly or indirectly the construction equipment vehicle's propulsion power.

5.4.1.3 When leaving the construction equipment vehicle, the driver /operator shall be informed by a signal (e.g. optical or audible signal) if the construction equipment vehicle is still in the active driving and/or operation possible mode.

5.4.1.4 If the on-board REESS can be externally charged by the driver/operator, construction equipment vehicle movement and/or operation and/or work cycle by its own propulsion and/or power-train system shall be impossible as long as the connector of the external electric power supply is physically connected to the construction equipment vehicle inlet. Compliance with this requirement shall be demonstrated by using the connector specified by the construction equipment vehicle manufacturer.

In case of permanently connected charge cables, the requirement above is deemed to be met when use of the charge cable obviously prevents the use of the construction equipment vehicle (e.g. cable is always routed over operator controls, rider's saddle, driver's seat, handle bar or steering wheel, or the seat covering the cable storage space needs to remain in open position).

5.4.1.5 If construction equipment vehicle is equipped with a drive/operation direction control unit (i.e. reversing device) the state of this unit shall be identified to the rider.

5.4.1.6 It is permitted that only one action is required to deactivate the active driving and/or operation possible mode or to complete the power-off procedure.

5.4.2 Driving and/or Operating work cycle with reduced power

5.4.2.1 Indication of reduced power

If the electric propulsion and/or power-train system is equipped with a means to automatically reduce the construction equipment vehicle propulsion and/or operating power (e.g. powertrain malfunction operating mode), significant reductions shall be indicated to the rider.

5.4.2.2 **Indication of low energy content of REESS**

If the state of charge in the REESS has a significant impact on construction equipment vehicle driving and/or operating work cycle performance (i.e. acceleration and drivability, operating to be evaluated by the Test Agency together with the construction equipment vehicle manufacturer), a low energy content shall be indicated to the rider by an obvious device (e.g. a visual or audible signal). The indication used for point 5.4.2.1 shall not be used for this purpose.

5.4.3 **Driving backwards**

It shall not be possible to activate the construction equipment vehicle reverse control function in an uncontrolled manner whilst the construction equipment vehicle is in forward motion, insofar as such activation could cause a sudden and strong deceleration or wheel lock. However, it may be possible for the vehicle reverse control function to be activated in such a way that it may slow down the vehicle gradually.

5.4.4 **Determination of hydrogen emissions**

5.4.4.1 This verification shall be carried out on construction equipment vehicle equipped with open type traction batteries and all requirements shall be met.

5.4.4.2 Construction equipment vehicle shall be equipped with on-board chargers. The tests shall be conducted following the method described in Annex 8 to AIS 038 (Rev. 2). The hydrogen sampling and analysis shall be the ones as prescribed, however, other analysis methods may be used provided that it can be demonstrated that these give equivalent results.

5.4.4.3 During a normal charge procedure under the conditions given in Annex 8 to AIS 038 (Rev. 2), hydrogen emissions shall be $< 125 \text{ g}$ measured over 5 hours, or below $(25 \times t_2)$ (g) during t_2 (h).

5.4.4.4 During a charge carried out by an on-board charger presenting a failure (conditions given in Annex 8 to AIS 038 (Rev. 2)), hydrogen emissions shall be below 42 g. Furthermore the on-board charger shall limit this possible failure to 30 minutes.

5.4.4.5 All the operations linked to the REESS charging shall be controlled automatically, included the stop for charging.

5.4.4.6 It shall not be possible to manually override the charging phases.

5.4.4.7 Normal operations of connection and disconnection to the mains or power cuts shall not affect the control system of the charging phases.

5.4.4.8 Charging failures that can lead to a malfunction of the on-board charger during subsequent charging procedures shall be permanently signaled to the driver or clearly indicated to the operator about to commence a charging procedure.

- 5.4.4.9 Detailed instructions concerning the charging procedure and a statement of conformity to the requirements as set out in points 5.4.4.1 to 5.4.4.8 shall be included in the construction equipment vehicle's instruction manual.
- 5.4.4.10 Test results obtained from other construction equipment vehicle types common to those within the same family, in accordance with the provisions laid down in Appendix 2 of Annex 8 to standard AIS 038 (Rev. 2), may be applied.

5.5 **Protection against Water Effects**

The test as per 5.5.1, 5.5.2 and 5.5.3 shall be performed. After each exposure (construction equipment vehicle still wet), the construction equipment vehicle shall then comply with the isolation resistance test with at least 100 Ω/V of nominal voltage, but keeping the power equipment connected to the REESS (main switch closed), and before water test isolation resistance with at least 500 Ω/V of nominal voltage.

These tests shall not apply to construction equipment vehicle having chassis connected electrical circuits where the maximum voltage between any live part and the electrical chassis or any exposed conductive part does not exceed 30V AC (rms) or 60 V DC.

5.5.1 **Washing**

This test is intended to simulate a normal washing of Electric Power Train construction equipment vehicle, but not specific cleaning using high water pressure or underbody washing. The construction equipment vehicle manufacturer shall specify detailed conditions for such specific cleaning or washing in the owner's manual. The critical areas of the construction equipment vehicle regarding this test are border lines i.e. a seal of two parts as flaps, glass seals, outline of opening parts, outline of front grille, seals of lamps.

In the case of open construction equipment vehicle such as, without doors and windows, the manufacturer shall specify the procedure for normal washing also. In such cases, the washing test shall be conducted by taking into account the above recommendation.

The test uses a hose nozzle according to IPX5 as specified in IEC 60529 (Refer Annex - 4 of this standard). Using fresh water with a flow rate of 12.5 l/min, all borderlines shall be exposed and followed in all directions with the water stream at a speed rate of 0.1 m/s, keeping a distance of 3 m between the nozzle aperture and the borderline.

5.5.2 **Flooding**

This test is intended to simulate the driving of an Electric Power Train construction equipment vehicle on flooded streets or in water puddles.

The construction equipment vehicle shall be driven in a wade pool, with water depth equivalent to from centre of front axle of construction equipment vehicle, over a distance of 500 m at a speed of 20 km/h or maximum speed whichever is lower.

If the wade pool used is less than 500 m in length, so that it has to be driven through several times, the total time including the periods outside the wade pool shall be less than 10 min.

5.5.3 Heavy Rainstorm

This test is intended to simulate a sudden heavy rainstorm e.g. a thunderstorm, when opening parts specially to access to the operator's work place, load and motor compartments, any other body area is open except those requiring one or more tools.

In case of voltage class B equipment shielded from exposure to water, this test of the whole construction equipment vehicle may be replaced by equivalent tests on the components individually.

The critical areas of the construction equipment vehicle regarding this test are those accessible with opened opening parts. This test uses a spray nozzle according to IPX3 as specified in IEC 60529.

Using fresh water with a flow rate of 10 l/min, all surfaces with normally open opening parts shall be exposed for 5 min, possibly through a regular movement of the spray nozzle.

Note: Voltage class B equipment is an equipment with nominal voltage (U)

DC: $60 \text{ V} < U \leq 1500 \text{ V}$

AC: $30 \text{ V rms} < U \leq 1000 \text{ V rms} - 15 \text{ to } 150 \text{ Hz}$

6.0 REQUIREMENTS OF A RECHARGEABLE ELECTRICAL ENERGY STORAGE SYSTEM (REESS) WITH REGARD TO ITS SAFETY

REESS shall meet the requirements of Part II of AIS-038 Rev 2 standard as amended from time to time.

7.0 TRACTION MOTOR POWER TEST

7.1 Motor Power Test: Test shall be carried out as per AIS-041(Rev. 1) using Bench Dynamometer Procedure.

7.2 Construction equipment vehicle Manufacture shall declare maximum PTO power, in technical specifications as per AIS 007 format and in Annex 5 format of this standard. (Only if, PTO is present in construction equipment vehicle)

8.0 EMC TEST

8.1 The Rechargeable Energy Storage System (REESS) of construction equipment vehicle shall be charged according to the following Normal overnight charge procedure.

- a) With the on-board charger, if fitted,
- b) With an external charger recommended by the manufacturer using the charging pattern prescribed for normal charging,
- c) In an ambient temperature comprised between 20 °C and 30 °C.

The procedure excludes all type of special charges that could be automatically or manually initiated like, for instance, the equalization charges or the servicing charges. The construction equipment vehicle manufacturer shall declare that during the test, a special charge procedure has not occurred.

8.2 Electro Magnetic Compatibility (EMC) tests shall be done on construction equipment vehicle as per IS / ISO 13766 (Part 1):2018 and IS / ISO 13766 (Part 2):2018, in configuration other than “REESS charging mode coupled to the power grid” (means construction equipment vehicle not in charging condition)

8.3 **Electric Construction Equipment Vehicle :Machinery state during test**

EMC tests shall be done as per IS / ISO 13766 (Part 1):2018 and IS / ISO 13766 (Part 2):2018 standard. Electric Motor of Construction Equipment Vehicle shall be at constant speed corresponding to three quarters of the maximum speed of the Electric Motor, if there is no technical reason for the manufacturer to prefer another speed. The electric motor shall be loaded with an appropriate torque. If need be, the transmission shafts may be disengaged, provided they do not drive a component-emitting interference.

8.4 **Hybrid Electric Construction Equipment Vehicle :Machinery state during test**

For radiated emission test as per IS / ISO 13766 (Part 1):2018 and IS / ISO 13766 (Part 2):2018 standard, of Hybrid Electric Construction Equipment Vehicle shall be tested, over the specified frequency range with both the combustion engine and electric drive running, with constant speed corresponding to three quarters of its maximum speed, if there is no technical reason for the manufacturer to prefer another speed. The vehicle's drive train shall be loaded with an appropriate torque. If need be, the transmission shafts may be disengaged, provided they do not drive a component-emitting interference.

If the above condition is not possible, two separate tests shall be conducted as follows:

8.4.1 **Electric Motor Drive Mode:**

Radiated emission test shall be conducted as per IS / ISO 13766 (Part 1):2018 and IS / ISO 13766 (Part 2):2018 standard, provided that a continuous power source may be supplied to the Rechargeable Energy Storage System (REESS) to keep the vehicle's electric motor running without starting the combustion engine, at maximum possible setting.

Manufacturer may facilitate this through service mode.

8.4.2 **Engine Mode:**

The test shall be conducted as per IS / ISO 13766 (Part 1):2018 and IS / ISO 13766 (Part 2):2018 standard, as applicable for engine type. Manufacturer may recommend energy storage level of REESS, such that combustion engine does not charge the REESS during the test.

8.4.3 Radiated Immunity test shall be done as per IS / ISO 13766 (Part 1):2018 and IS / ISO 13766 (Part 2):2018 standard for Hybrid Electric Construction Equipment Vehicle at constant speed corresponding to three quarters of the maximum speed of electric motor and/or engine if there is no technical reason for the manufacturer to prefer another speed. The vehicle's drive train shall be loaded with an appropriate torque. If need be, the transmission shafts may be disengaged, provided they do not drive a component-emitting interference.

9.0 **Criteria for Extension of Approval**

9.1. Every modification of the construction equipment vehicle or REESS type with regard to this Standard shall be notified to the Test Agency which approved the construction equipment vehicle or REESS type. The Test Agency may then either:

9.1.1. Consider that the modifications made are unlikely to have an appreciable adverse effect and that in any case the construction equipment vehicle or the REESS still complies with the requirements, or

9.1.2. Require a further testing by Test Agency for necessary compliance of construction equipment vehicle or REESS to this standard.

10.0 **TECHNICAL SPECIFICATIONS**

10.1 Construction equipment vehicle manufacturer shall submit test vehicle specification in Annex 5 format for type approval.

10.2 Construction equipment vehicle manufacturer or REESS manufacturer shall submit technical specifications of REESS in Annex 6 format for type approval.

ANNEX 1

(See 5.2.3.2.)

**ISOLATION RESISTANCE MEASUREMENT METHOD FOR VEHICLE
BASED TESTS****1.0 General**

The isolation resistance for each high voltage bus of the vehicle shall be measured or shall be determined by calculation using measurement values from each part or component unit of a high voltage bus (hereinafter referred to as the "divided measurement").

2.0 Measurement method

The isolation resistance measurement shall be conducted by selecting an appropriate measurement method from among those listed in paragraphs 2.1. through 2.2. of this annex, depending on the electrical charge of the live parts or the isolation resistance, etc.

The range of the electrical circuit to be measured shall be clarified in advance, using electrical circuit diagrams, etc.

Moreover, modification necessary for measuring the isolation resistance may be carried out, such as removal of the cover in order to reach the live parts, drawing of measurement lines, change in software, etc.

In cases where the measured values are not stable due to the operation of the on-board isolation resistance monitoring system, etc., necessary modification for conducting the measurement may be carried out, such as stopping of the operation of the device concerned or removing it. Furthermore, when the device is removed, it shall be proven, using drawings, etc., that it will not change the isolation resistance between the live parts and the electrical chassis.

Utmost care shall be exercised as to short circuit, electric shock, etc., for this confirmation might require direct operations of the high-voltage circuit.

2.1. Measurement method using voltage from off-vehicle sources**2.1.1. Measurement instrument**

An isolation resistance test instrument capable of applying a DC voltage higher than the working voltage of the high voltage bus shall be used.

2.1.2. Measurement method

An insulator resistance test instrument shall be connected between the live parts and the electrical chassis. Then, the isolation resistance shall be measured by applying a DC voltage at least half of the working voltage of the high voltage bus.

If the system has several voltage ranges (e.g. because of boost converter) in galvanically connected circuit and some of the components cannot withstand the working voltage of the entire circuit, the isolation resistance between those components and the electrical chassis can be measured separately by applying at least half of their own working voltage with those component disconnected.

2.2. Measurement method using the vehicle's own REESS as DC voltage source

2.2.1. **Test vehicle conditions**

The high voltage-bus shall be energized by the vehicle's own REESS and/or energy conversion system and the voltage level of the REESS and/or energy conversion system throughout the test shall be at least the nominal operating voltage as specified by the vehicle manufacturer.

2.2.2. **Measurement instrument**

The voltmeter used in this test shall measure DC values and shall have an internal resistance of at least 10 M Ω .

2.2.3. **Measurement method**

2.2.3.1. **First step**

The voltage is measured as shown in Figure 1 and the high voltage bus voltage (V_b) is recorded. V_b shall be equal to or greater than the nominal operating voltage of the REESS and/or energy conversion system as specified by the vehicle manufacturer.

Figure 1

Measurement of V_b , V_1 , V_2

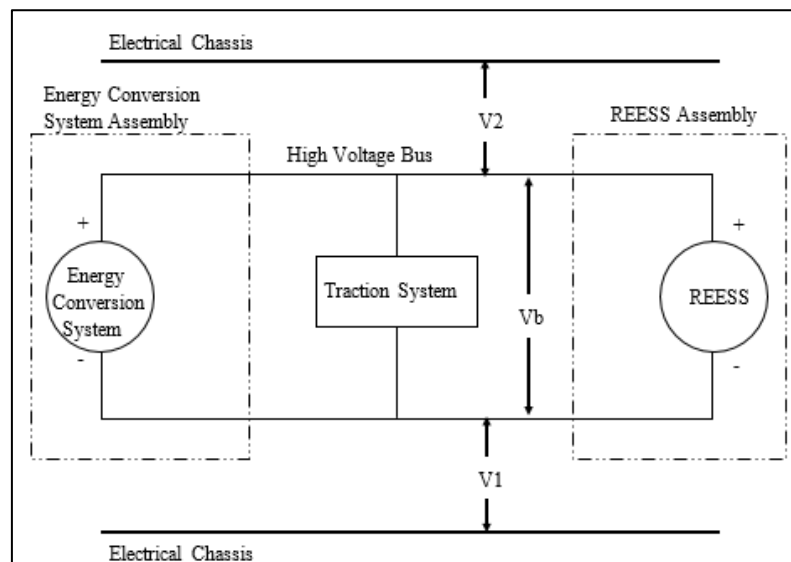

2.2.3.2. **Second step**

Measure and record the voltage (V_1) between the negative side of the high voltage bus and the electrical chassis (see Figure 1).

2.2.3.3. **Third step**

Measure and record the voltage (V2) between the positive side of the high voltage bus and the electrical chassis (see Figure 1).

2.2.3.4. **Fourth step**

If V1 is greater than or equal to V2, insert a standard known resistance (Ro) between the negative side of the high voltage bus and the electrical chassis. With Ro installed, measure the voltage (V1') between the negative side of the high voltage bus and the electrical chassis (see Figure 2).

Calculate the electrical isolation (Ri) according to the following formula:

$$R_i = R_o * (V_b / V_1' - V_b / V_1) \quad \text{or} \quad R_i = R_o * V_b * (1 / V_1' - 1 / V_1)$$

Figure 2

Measurement of V1

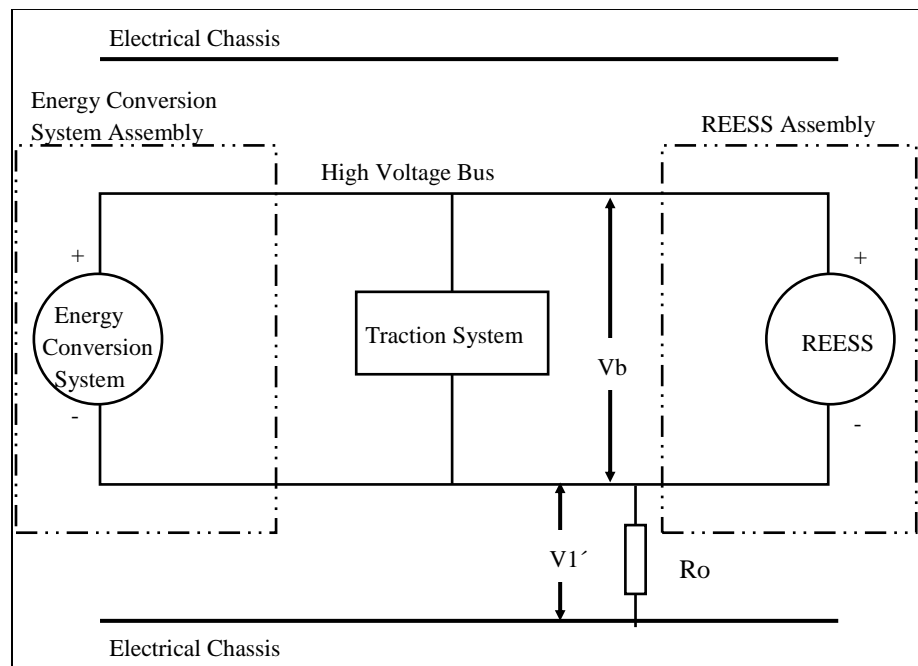

If V2 is greater than V1, insert a standard known resistance (Ro) between the positive side of the high voltage bus and the electrical chassis. With Ro installed, measure the voltage (V2') between the positive side of the high voltage bus and the electrical chassis (see Figure 3). Calculate the electrical isolation (Ri) according to the formula shown. Divide this electrical isolation value (in Ω) by the nominal operating voltage of the high voltage bus (in Volts).

Calculate the electrical isolation (Ri) according to the following formula:

$$R_i = R_o * (V_b / V_2' - V_b / V_2) \quad \text{or} \quad R_i = R_o * V_b * (1 / V_2' - 1 / V_2)$$

Figure 3
Measurement of V2

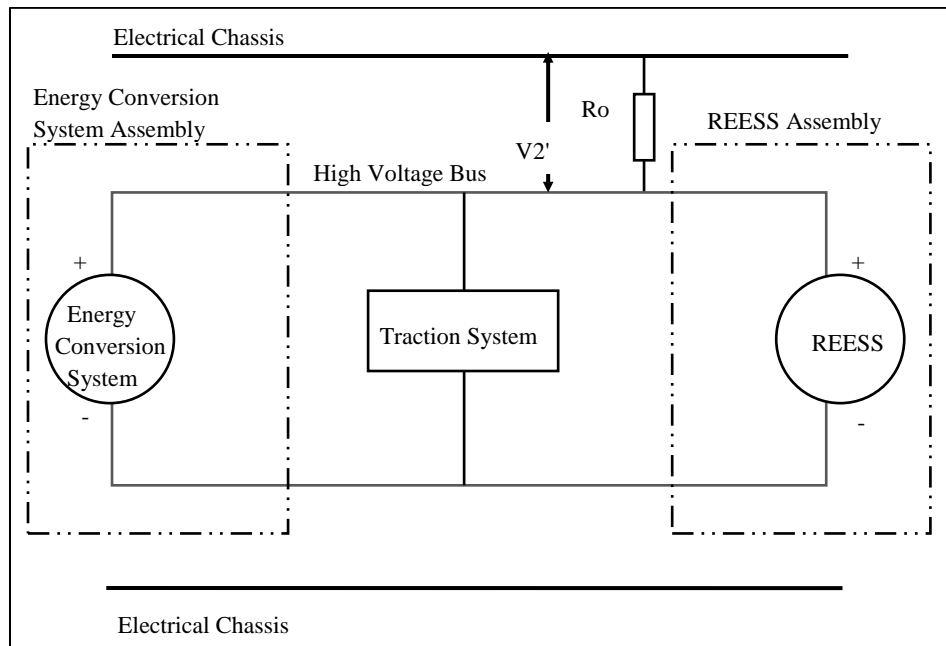

2.2.3.5. Fifth step

The electrical isolation value R_i (in Ω) divided by the working voltage of the high voltage bus (in Volts) results in the isolation resistance (in Ω/V).

Note: The standard known resistance R_o (in Ω) should be the value of the minimum required isolation resistance (in Ω/V) multiplied by the working voltage of the vehicle plus/minus 20 per cent (in volts). R_o is not required to be precisely this value since the equations are valid for any R_o ; however, a R_o value in this range should provide good resolution for the voltage measurements.

ANNEX 2

(See 5.2.3.3. b)

**CONFIRMATION METHOD FOR FUNCTION OF ON-BOARD ISOLATION
RESISTANCE MONITORING SYSTEM**

- 1.0 The function of the on-board isolation resistance monitoring system shall be confirmed by the following method:

Insert a resistor that does not cause the isolation resistance between the terminal being monitored and the electrical chassis to drop below the minimum required isolation resistance value. The warning shall be activated.

ANNEX 3

(See 5.2.1)

PROTECTION AGAINST DIRECT CONTACTS OF PARTS UNDER VOLTAGE**1.0 Access probes**

Access probes to verify the protection of persons against access to live parts are given in Table 1.

2.0 Test conditions

The access probe is pushed against any openings of the enclosure with the force specified in Table 1. If it partly or fully penetrates, it is placed in every possible position, but in no case shall the stop face fully penetrate through the opening.

Internal barriers are considered part of the enclosure.

A low-voltage supply (of not less than 40 V and not more than 50 V) in series with a suitable lamp should be connected, if necessary, between the probe and live parts inside the barrier or enclosure.

The signal-circuit method should also be applied to the moving live parts of high voltage equipment.

Internal moving parts may be operated or otherwise repositioned slowly, where this is possible.

3.0 Acceptance conditions

The access probe shall not touch live parts.

If this requirement is verified by a signal circuit between the probe and live parts, the lamp shall not light.

In the case of the test for IPXXB, the jointed test finger may penetrate to its 80 mm length, but the stop face (diameter 50 mm x 20 mm) shall not pass through the opening. Starting from the straight position, both joints of the test finger shall be successively bent through an angle of up to 90 degrees with respect to the axis of the adjoining section of the finger and shall be placed in every possible position.

In case of the tests for IPXXD, the access probe may penetrate to its full length, but the stop face shall not fully penetrate through the opening.

Table 1

ACCESS PROBES FOR THE TESTS FOR PROTECTION OF PERSONS AGAINST ACCESS TO HAZARDOUS PARTS

First numeral	Addit. letter	Access probe (Dimensions in mm)	Test force
2	B	<p style="text-align: center;">Jointed test finger</p>  <p style="text-align: center;">See Fig.1 for full dimensions</p> <p style="text-align: center;">Insulating material</p> <p style="text-align: center;">Jointed test finger (Metal)</p> <p style="text-align: center;">Stop face (∅ 50 x 20)</p> <p style="text-align: center;">∅ 12</p> <p style="text-align: center;">80</p>	10 N±10%
4, 5, 6	D	<p style="text-align: center;">Test wire 1.0 mm diameter, 100 mm long</p>  <p style="text-align: center;">Sphere 35±0.2</p> <p style="text-align: center;">Approx. 100</p> <p style="text-align: center;">100±0.2</p> <p style="text-align: center;">∅ 10</p> <p style="text-align: center;">∅ 1 +0.05 / 0</p> <p style="text-align: center;">Handle (Insulating material)</p> <p style="text-align: center;">Stop face (Insulating material)</p> <p style="text-align: center;">Rigid test wire (Metal)</p> <p style="text-align: center;">Edges free from burrs</p>	1N±10%

Figure 1

JOINTED TEST FINGER

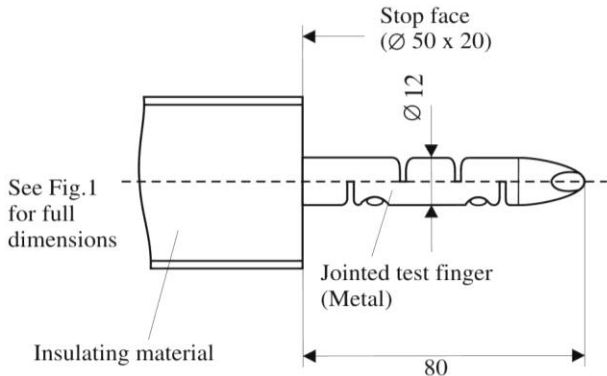
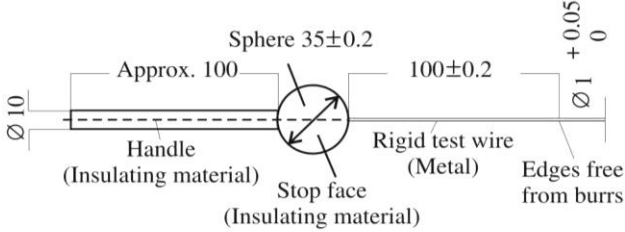
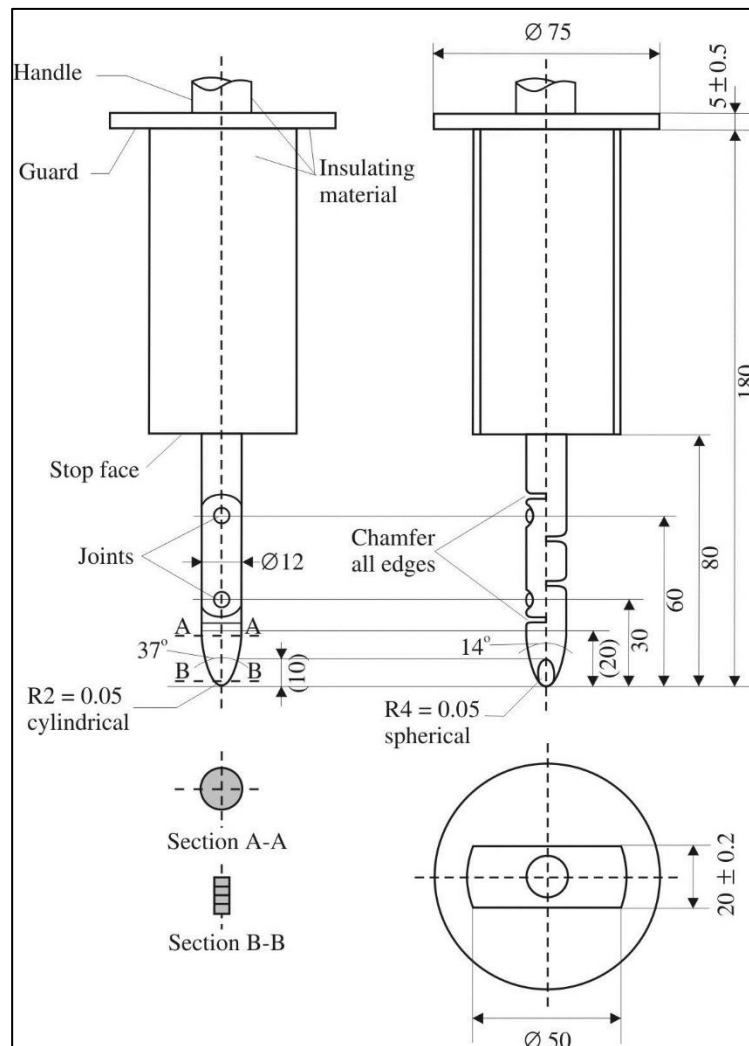

Material: metal, except where otherwise specified

Linear dimensions in millimeters

Tolerances on dimensions without specific tolerance:

(a) On angles: $0/-10^\circ$;

(b) On linear dimensions: up to 25 mm: $0/-0.05$ mm over 25 mm: ± 0.2 mm

Both joints shall permit movement in the same plane and the same direction through an angle of 90° with a 0 to $+10^\circ$ tolerance.

ANNEX 4

(See 5.5.1.)

HOSE NOZZLE FOR THE TEST FOR PROTECTION AGAINST WASHING

This Annex specifies dimensionally the hose nozzle to be used for IPX5 test procedure as specified in IEC 60529 (All dimensions are in mm).

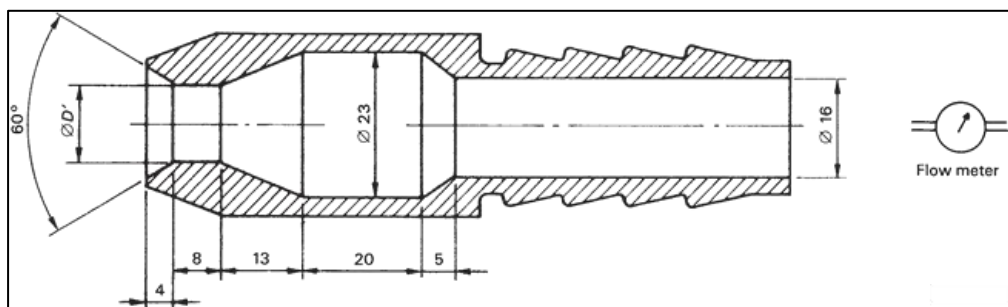
Test device to verify protection against water jets (hose nozzle)

ANNEX 5

(In addition to of AIS 007 (Rev. 5) applicable tables. e.g Table 13, Table 14,15,15A etc.)

(See 3.1.2.)

**ESSENTIAL CHARACTERISTICS OF ELECTRIC POWER TRAIN
CONSTRUCTION EQUIPMENT VEHICLE**

1.0	General
1.1.	Mark (trade name of manufacturer):
1.2.	Type/Designation as per IS/ISO 6165/CMVR:
1.3.	Construction Equipment Vehicle Category:
1.4.	Model Name
1.5.	Manufacturer's name and address:
1.6.	If applicable, name and address of manufacturer's representative:
1.7.	Drawing and/or photograph of the Construction Equipment Vehicle:
1.8.	Type Approval Report number of the REESS:
1.9	Propulsion system (e.g. hybrid, electric):
2.0	Electric motor (traction motor)
2.1.	Type (winding, excitation):
2.2.	Maximum net power and / or maximum 30 minutes power (kW) as per AIS 041: Rev 1:2015 as amended and revised from time to time
2.3	Max PTO Power (kW) (Declared Value)
2.4	Rated PTO Power (kW) (Declared Value)
3.0	Engine (If Hybrid Electric CEV)
3.1	Make
3.2	Model
3.3	Type
3.4	Bore x stroke (mm)
3.5	No. of cylinders
3.6	Displacement

3.7	Compression ratio
3.8	Max. Engine output (kW @ rpm)
3.9	Max. Torque (Nm @ rpm)
4.0	Engine ECU (If Hybrid Electric CEV)
4.1	Make
4.2	Model
4.3	Hardware Version
4.4	Software Version
5.0	REESS
5.1.	Trade name and mark of the REESS:
5.2.	Indication of all types of cells:
5.2.1.	The cell chemistry:
5.2.2.	Physical dimensions:
5.2.3.	Capacity of the cell (Ah):
5.3.	Description or drawing(s) or picture(s) of the REESS explaining:
5.3.1.	Structure:
5.3.2.	Configuration (number of cells, mode of connection, etc.):
5.3.3.	Dimensions:
5.3.4.	Casing (construction, materials and physical dimensions):
5.4.	Electrical specification:
5.4.1.	Nominal voltage (V):
5.4.2.	Working voltage (V):
5.4.3.	Rated capacity (Ah):
5.4.4.	Maximum current (A):
5.5.	Gas combination rate (in per cent):
5.6.	Description or drawing(s) or picture(s) of the installation of the REESS in the Construction Equipment Vehicle:

5.6.1.	Physical support:
5.7.	Type of thermal management
5.8.	Electronic control:
6.0	Fuel Cell (if any)
6.1.	Trade name and mark of the fuel cell:
6.2.	Types of fuel cell:
6.3.	Nominal voltage (V):
6.4.	Number of cells:
6.5.	Type of cooling system (if any):
6.6.	Max Power (kW):
7.0	Fuse and/or circuit breaker
7.1.	Type:
7.2.	Diagram showing the functional range:
8.0	Power wiring harness
8.1.	Type:
9.0	Protection against Electric Shock
9.1.	Description of the protection concept:
10.0	Additional data
10.1.	Brief description of the power circuit components installation or drawings/ pictures showing the location of the power circuit components installation:
10.2.	Schematic diagram of all electrical functions included in power circuit:
10.3.	Working voltage (V):
10.4.	System descriptions for low performance driving mode(s)
10.4.1.	Systems' SOC level(s) for which power reduction is activated, descriptions, rationales
10.4.2.	Descriptions for systems' reduced power mode(s) and similar mode(s), rationales

ANNEX 6	
(SEE 4.1.2.)	
ESSENTIAL CHARACTERISTICS OF REESS	
1.0	REESS
1.1.	Trade name and mark of the REESS:
1.2.	Indication of all types of cells:
1.2.1.	The cell chemistry:
1.2.2.	Physical dimensions:
1.2.3.	Capacity of the cell (Ah):
1.3.	Description or drawing(s) or picture(s) of the REESS explaining
1.3.1.	Structure:
1.3.2.	Configuration (number of cells, mode of connection, etc.):
1.3.3.	Dimensions:
1.3.4.	Casing (construction, materials and physical dimensions):
1.3.5.	Mass of REESS (kg):
1.4.	Electrical specification
1.4.1.	Nominal voltage (V):
1.4.2.	Working voltage (V):
1.4.3.	Rated capacity (Ah):
1.4.4.	Maximum current (A):
1.5.	Gas combination rate (in percentage):
1.6.	Description or drawing(s) or picture(s) of the installation of the REESS in the vehicle:
1.6.1.	Physical support:
1.7.	Type of thermal management:
1.8.	Battery Management System (BMS)
1.8.1	Make

1.8.2	Model Number / Part Number
1.8.3	Software Version
1.8.4	Hardware Version
1.8.5	Architecture (attach circuit board diagram and Cell configuration structure)
1.8.6	Balancing Type (Active/Passive)
1.8.7	Communication Protocol
1.9.	Category of Construction Equipment Vehicle on which the REESS can be installed:
1.10	Type/Designation as per IS/ISO 6165/CMVR of Construction Equipment Vehicle on which the REESS can be installed:

ANNEX 7
(See Introduction)

**COMPOSITION OF AISC PANEL ON
SPECIFIC REQUIREMENTS FOR ELECTRIC POWER TRAIN
CONSTRUCTION EQUIPMENT VEHICLE***

Convener	
Mr. A.A. Deshpande	The Automotive Research Association of India (ARAI)
Members	Representing
Mr. M. M. Desai	The Automotive Research Association of India (ARAI)
Mr. Kamalesh Patil	The Automotive Research Association of India (ARAI)
KV Krishnamurthy	ICEMA
Ms. Paromita Chatterjee	ICEMA
Ms. Seema Gupta	ICEMA
Mr. Saurabh Dalela	JCB India Ltd.
Mr. Dheeraj Lohani	JCB India Ltd.
Mr. Vivek rawat	JCB India Ltd.
Mr. Karthik Kaliappan	John Deere India Pvt. Ltd.
Mr. Jagadish Bhat	Ajax Fiori Engineering (I) Pvt. Ltd
Mr. Venkataramani Bhaskaran	Caterpillar India Ltd.
Mr. Reji k Jose	Caterpillar India Ltd.
Mr. Suresh Kumar M	Larsen & Toubro Limited
Shri Rajeev Shalia	Case Construction Equipment
Shri G. Rajendra	Mahindra & Mahindra Construction Equipment Division
Mr. M. Rajendran	Komatsu India Pvt. Ltd.
Mr. Sai Prasad Polipalli	Volvo Construction Equipment Ltd.
Mr. Karuppannan K	Propel Industries Pvt Ltd.
Mr. Saurabh Sehgal	ESCORT

* At the time of approval of this Automotive Industry Standard (AIS)

ANNEX 8
(See Introduction)

COMMITTEE COMPOSITION *
Automotive Industry Standards Committee

Chairperson	
Dr. Reji Mathai	Director The Automotive Research Association of India
Members	Representing
Representative from	Ministry of Road Transport and Highways
Representative from	Ministry of Heavy Industries
Representative from	Office of the Development Commissioner, MSME, Ministry of Micro, Small and Medium Enterprises
Shri R.R. Singh	Bureau of Indian Standards
Director	Central Institute of Road Transport
Director	Global Automotive Research Centre
Director	International Centre for Automotive Technology
Director	Indian Institute of Petroleum
Director	Vehicles Research and Development Establishment
Director	Indian Rubber Manufacturers Research Association
Representatives from	Society of Indian Automobile Manufacturers
Shri R. P. Vasudevan	The Tractor and Mechanization Association
Shri Uday Harite	Automotive Components Manufacturers Association of India
Shri K. V. Krishnamurthy	Indian Construction Equipment Manufactures' Association (ICEMA)
Member Secretary	
Shri Vikram Tandon	The Automotive Research Association of India

* At the time of approval of this Automotive Industry Standard (AIS)