

AUTOMOTIVE INDUSTRY STANDARD

**Driver-Perceived Noise Level of Agricultural
and Forestry Tractors – Method of
Measurement**

(Revision 1)

PRINTED BY
THE AUTOMOTIVE RESEARCH ASSOCIATION OF INDIA
P.B. NO. 832, PUNE 411 004

ON BEHALF OF
AUTOMOTIVE INDUSTRY STANDARDS COMMITTEE

UNDER
CENTRAL MOTOR VEHICLE RULES – TECHNICAL STANDING COMMITTEE

SET-UP BY
MINISTRY OF ROAD TRANSPORT & HIGHWAYS
(DEPARTMENT OF ROAD TRANSPORT & HIGHWAYS)
GOVERNMENT OF INDIA

July 2025

Clause No.	Contents	Page No.
1.	Scope	1/12
2.	Reference	1/12
3.	Definitions	1/12
4.	Method of Measurement	1/12
List of Annexes		
Annex I	Apparatus, Conditions and Method of Measurement	2/12
Annex II	Apparatus, Conditions and Method of Measurement	5/12
Annex III	Method for Determining the Seat Reference Point (S)	8/12
Annex IV	Composition of AISC Panel	11/12
Annex V	Automotive Industry Standards Committee	12/12

INTRODUCTION

The Government of India felt the need for a permanent agency to expedite the publication of standards and development of test facilities in parallel when the work on the preparation of the standards is going on, as the development of improved safety critical parts can be undertaken only after the publication of the standard and commissioning of test facilities. To this end, the erstwhile Ministry of Surface Transport (MOST) has constituted a permanent Automotive Industry Standards Committee (AISC) vide order No. RT-11028/11/97-MVL dated September 15, 1997. The standards prepared by AISC will be approved by the permanent CMVR Technical Standing Committee (CTSC). After approval, the Automotive Research Association of India, (ARAI), Pune, being the Secretariat of the AIS Committee, has published this standard. For better dissemination of this information ARAI may publish this document on their web site.

Presently the method of measurement of noise of Agricultural Tractor at the operator’s position is as per AIS 115 Part -1 and is in force. In the process of aligning our national standards with ECE regulations and EEC Directives, AIS 115 Part 1 is aligned with EEC Directive 77/311/EEC for driver – perceived noise level.

Further Directive 77/311/EEC for Driver –Perceived Noise Level has been repealed by Directive 2009/76/EC of the European Parliament and of the Council of 13 July 2009 which has also subsequently repealed by regulation (EU) No. 167/2013 of the parliament and of the council of 5 February 2013 and Commission delegated regulation (EU) 2015/96 of 1 October 2014 supplementing Regulation (EU) No 167/2013.

Hence it is proposed to align the text in this standard with latest applicable text as per Annex XIII of Commission Delegated Regulation (EU) No 1322/2014 of 19 September 2014 supplementing and amending Regulation (EU) No 167/2013.

Revised requirements of noise levels will be notified in CMVR. Part 2 of this standard covers measurement of permissible sound level at bystander’s of Agricultural Tractor.

While preparing this standard, considerable assistance has been derived from following International/ national standards:

<p>EEC directive– 77/311/EEC as amended by Directive 82/890/EEC, 97/54/EC and 2006/26/EC) and Annex XIII of Commission Delegated Regulation (EU) No 1322/2014 of 19 September 2014</p>	<p>on the approximation of the laws of the Member States relating to the driver-perceived noise level of wheeled agricultural or forestry tractors</p>
<p>IS: 12180 (Part 1): 2000/ISO 5131 : 1996</p>	<p>Tractors and Machinery for Agriculture and Forestry - Noise Measurement - Method of Test - Part 1 : Noise at The Operator's Position - Survey Method</p>

The AISC panel responsible for formulation of this standard is given in Annex IV. The Automotive Industry Standards Committee (AISC) responsible for approval of this standard is given in Annex V

Driver-Perceived Noise Level of Agricultural and Forestry Tractors – Method of Measurement

1.0 SCOPE

This standard specifies a method for measuring the A-weighted sound pressure level of the noise perceived by the driver emitted by Agricultural and Forestry Tractors and its categories as defined in AIS-053 & IS 14272 as applicable, while in motion.

2.0 REFERENCES

- 2.1 AIS-053 Automotive Vehicles – Types – Terminology
- 2.2 Commission Delegated Regulation (EU) No 1322/2014 of 19 September 2014 supplementing and amending Regulation (EU) No 167/2013 of the European Parliament and of the Council with regard to vehicle construction and general requirements for the approval of agricultural and forestry vehicles.
- 2.3 IS 14272: Automotive Vehicles – Types – Terminology

3.0 DEFINITIONS

For the purpose of this standard, the following definition shall apply:

- 3.1 Agricultural and Forestry Tractor and its Categories: As defined in 3.9 of AIS-053 and clause 3.8 of IS 14272.

4.0 METHOD OF MEASUREMENT

Method of measurement of driver perceived noise level emitted by tractor in drawbar- load method is specified in Annex- I and that in no-load method in Annex- II

Note: Agricultural and Forestry Tractor manufacturers can opt for testing as per Annex I or Annex II.

ANNEX-I

APPARATUS, CONDITIONS AND METHOD OF MEASUREMENT

(See 4.0)

1.0 UNIT OF MEASUREMENT AND MEASURING APPARATUS

1.1 Unit of measurement

Noise level shall be measured in dB with A-weighting, expressed as dB(A)

1.2 Measuring apparatus

A precision quality sound level meter shall be used meeting the requirements of the International Electro technical Commission Standards IEC 61672-1:2013 Electroacoustic - Sound level meters - Part 1: Specifications. Measurement shall be carried out with a frequency weighting network in conformity with curve A and set to give slow response as is described in the IEC publication.

1.2.1 The equipment shall be calibrated frequently and, if possible, before each measuring session.

1.2.2 An adequate technical description of measuring equipment shall be given in the test report.

1.2.3 In the case of variable readings, the average of the maximum values shall be taken.

2.0 CONDITIONS OF MEASUREMENT

Measurement shall be made under the following conditions:

2.1 The tractor shall be unladen, i.e, without optional accessories, but shall include coolant, lubricant, full fuel tank, tools and driver. The latter may not wear any abnormally thick clothing, scarf or hat. There may be no object on the tractor likely to distort the noise level;

2.2 The tyres shall be inflated to the manufacturers recommended pressure, the engine, transmission and drive axles shall be at normal running temperature and radiator blinds when fitted shall be kept open during measurements;

2.3 If it is liable to affect the noise level, extra equipment powered by the engine or self-powered such as wind screen wipers, warm air fan or power take-off, may not be in operation when measurements are being made; parts which normally operate at the same time as the engine, such as engine cooling fan, shall be in operation when measurements are being made;

2.3.1 At the discretion of the manufacturer, an additional optional noise measurement may be made with the engine stopped and auxiliaries such as ventilating fans, defrosters and other electrical facilities working at maximum settings;

2.4 The test area shall be in an open and sufficiently silent location; it may take the form, for instance, of an open space of 50-metre radius, having a central part with a radius of at least 20 m which is practically level, or of a level section having a solid track with as flat a surface and as few gullies as possible. The track shall be as clean and dry as possible (e.g. free of gravel, leaves, snow, etc.). Slopes and irregularities are acceptable only if the variations in noise level caused by them lie within the error tolerances of the measuring equipment;

2.5 The surface of the track shall be such as not to cause excessive tyre noise;

2.6 Meteorological conditions

The air temperature shall be in the range from -5 °C to 30 °C and the wind velocity shall not exceed 5 m/s at the operator's position. Other meteorological conditions shall be such that they do not influence the measurements.

The driver perceived ambient noise level due to wind or other source of noise shall be at least 10 dB(A) below the noise level of the tractor;

2.7 If a vehicle is used for measurements, it shall be towed or driven at sufficient distance from the tractor to avoid all interference. During measurements no object interfering with the measurements or reflective surfaces may be located within 20m of each side of the test track and less than 20m to the front or rear of the tractor. This condition can be considered fulfilled if the variation in noise level thus caused remain within the error tolerances; if not measurement shall be discontinued for the duration of interference.

2.8 All measurements on the given series shall be carried out on the same track.

2.9 All readings of the sound level meter shall be taken with the time weighting S.

3.0 METHOD OF MEASUREMENT

3.1 The microphone shall be located 250 mm to the side of the centre plane of the seat, the side being that on which the higher level of noise is encountered. The axis of the microphone shall be horizontal.

The microphone diaphragm shall face forward and centre of microphone shall be 790mm above and 150 mm forward of the seat reference point as described in Annex-III. Excessive vibration of microphone shall be avoided.

3.2 The maximum noise level in dB(A) shall be determined as follows:

3.2.1 All openings (e.g. doors, windows) in tractors having a closed series produced cab structure shall be closed during an initial series of measurements.

- 3.2.1.1 During a second series of measurements they shall be left open, provided that when open they do not create a road safety hazard, but fold-down or fold-up windscreens shall remain closed;

Note: Measurements with doors, windows and hatches open are made for information purposes only, to ensure that the user is made aware of any operating conditions where sound pressure levels could be harmful and exceed those measured in a closed cab.

- 3.2.3 Noise shall be measured using slow sound level metre response at the load corresponding to the maximum noise level in the gear giving the forward speed nearest to 7.5kmph. The governor control lever shall be fully open. Starting with no load gradually increase load till the maximum noise level is found. After each increase in load, time shall be given for the noise level to stabilize before the measurement is recorded.

- 3.2.4 Noise shall be measured using slow sound level metre response at the load corresponding to the maximum noise level in any gear other than the gear specified in 3.2.2 in which the noise level recorded is at least 1dB(A) above than what recorded in the gear referred in 3.2.2. The governor control lever shall be fully open. Starting with no load, gradually increase load till the maximum noise level is found. After each increase in load, time shall be given for the noise level to stabilize before the measurement is recorded.

- 3.2.5 Noise shall be measured at the maximum design speed of the unladen tractor.

- 3.2 The test report shall include noise level measurements in forward speed carried out in following conditions

- 3.3.1 in the gear giving the speed nearest to 7.5 kmph.

- 3.3.2 in any gear, if the conditions described in 3.2.3 are fulfilled;

- 3.3.3 at maximum design speed.

4.0 ASSESMENT CRITERIA

The measurements described in 3.2.1, 3.2.2, 3.2.3 and 3.2.4 shall not exceed the values as prescribed in CMVR

ANNEX-II**APPARATUS, CONDITIONS AND METHOD OF MEASUREMENT**

(See 4.0)

1.0 UNIT OF MEASUREMENT AND MEASURING APPARATUS**1.1 Unit of measurement**

Noise level shall be measured in dB with A-weighting, expressed as dB(A)

1.2 Measuring apparatus

A precision quality sound level meter shall be used meeting the requirements of the International Electro technical Commission Standards IEC 61672-1:2013 Electroacoustic - Sound level meters - Part 1: Specifications. Measurement shall be carried out with a frequency weighting network in conformity with curve A and set to give slow response as is described in the IEC publication.

1.2.1 The equipment shall be calibrated frequently and, if possible, before each measuring session.

1.2.2 An adequate technical description of measuring equipment shall be given in the test report.

1.2.3 In the case of variable readings, the average of the maximum values shall be taken.

2.0 CONDITIONS OF MEASUREMENT

Measurement shall be made under the following conditions

2.1 The tractor shall be unladen, i.e, without optional accessories, but shall include coolant, lubricant, full fuel tank, tools and driver. The latter may not wear any abnormally thick clothing, scarf or hat. There may be no object on the tractor likely to distort the noise level.

2.2 The tyres shall be inflated to the manufacturers recommended pressure, the engine transmission and drive axles shall be at normal running temperatures and if the engine has cooling louvers, these shall remain completely open.

2.3 If it is liable to affect the noise level, extra equipment powered by the engine or self powered such as wind screen wipers, warm air fan or power take-off, may not be in operation when measurements are being made; parts which normally operate at the same time as the engine, such as engine cooling fan, shall be in operation when measurements are being made.

2.3.1 At the discretion of the manufacturer, an additional optional noise measurement may be made with the engine stopped and auxiliaries such as

ventilating fans, defrosters and other electrical facilities working at maximum settings;

2.4 The test area shall be in an open and sufficiently silent location; it may take the form, for instance, of an open space of 50-metre radius, having a central part with a radius of at least 20 m which is practically level, or of a level section having a solid track with as flat a surface and as few gullies as possible. The track shall be as clean and dry as possible (e.g. free of gravel, leaves, snow, etc.). Slopes and irregularities are acceptable only if the variations in noise level caused by them lie within the error tolerances of the measuring equipment.

2.5 The surface of the track shall be such as not to cause excessive tyre noise

Meteorological conditions

The air temperature shall be in the range from -5 °C to 30 °C and the wind velocity shall not exceed 5 m/s at the operator's position. Other meteorological conditions shall be such that they do not influence the measurements. The driver perceived ambient noise level due to wind or other source of noise shall be at least 10 dB(A) below the noise level of the tractor.

If a vehicle is used for measurements, it shall be towed or driven at sufficient distance from the tractor to avoid all interference. During measurements no object interfering with the measurements or reflective surfaces may be located within 20m of each side of the test track or less than 20m to the front or rear of the tractor. This condition can be considered fulfilled if the variation in noise level thus caused remain within the error tolerances. If not, measurement shall be discontinued for the duration of interference.

2.6 All measurements on the given series shall be carried out on the same track.

2.7 All readings of the sound level meter shall be taken with the time weighting S.

3.0 METHOD OF MEASUREMENT

3.1 The microphone shall be located 250 mm to the side of the centre plane of the seat, the side being that on which the higher level of noise is encountered. The axis of microphone shall be horizontal. The microphone diaphragm shall face forward and centre of microphone shall be 790 mm above and 150 mm forward of seat reference point as described in Annex-III. Excessive vibration of microphone shall be avoided.

3.2 The maximum noise level in dB(A) shall be determined as follows:

3.2.1 The tractor shall travel along the same section at the same test speed at least three times for at least 10 seconds.

3.2.2 All openings (e.g. doors, windows) in tractors having a closed series produced cab structure shall be closed during an initial series of measurements.

3.2.2.1 During a second series of measurements they shall be left open, provided that when open they do not create a road safety hazard, but fold-down or fold-up windscreens shall remain closed;

Note: Measurements with doors, windows and hatches open are made for information purposes only, to ensure that the user is made aware of any operating conditions where sound pressure levels could be harmful and exceed those measured in a closed cab.

3.2.2.2 During the optional third series of measurements the engine shall be stopped and auxiliaries such as ventilating fans, defrosters and other electrical facilities shall be working at maximum settings;

3.2.3 Noise shall be measured at the maximum rpm using slow sound level metre response i.e in the gear giving the speed nearest to 7.5 kmph at the rated rpm. The tractor shall be unladen when measurements are being made

4.0 ASSESMENT CRITERIA

The measurements described in 3.2.2 and 3.2.3 shall not exceed the values as prescribed in CMVR.

ANNEX III**METHOD FOR DETERMINING THE SEAT REFERENCE POINT (S)**

1. Device for determining the seat reference point (S)

The device illustrated in Figure 1 consists of a seat pan board and backrest boards. The lower backrest boards must be hinged in the region of the ischium humps (A) and the loin (B), the hinge (B) being adjustable in height.

2. Method of determining the seat reference point (S)

The seat reference point (S) must be obtained by using the device illustrated in Figures 1 and 2, which simulates loading by a human occupant. The device must be positioned on the seat. It must then be loaded with a force of 550 N at a point 50 mm in front of hinge (A) and two parts of the backrest lightly pressed tangentially against the padded backrest.

If it is not possible to determine definite tangents to each area of the padded backrest (below and above the lumbar region) the following procedure must be adopted:

- (a) where there is no possibility of defining the tangent to the lowest possible area, the lower part of the backrest board in a vertical position must be lightly pressed against the padded backrest;
- (b) where there is no possibility of defining the tangent to the highest possible area, if the lower part of the backrest board is vertical, the hinge must be fixed at a height of 230 mm above the seat reference point (S). The two parts of the backrest board in a vertical position must then be lightly pressed tangentially against the padded backrest.

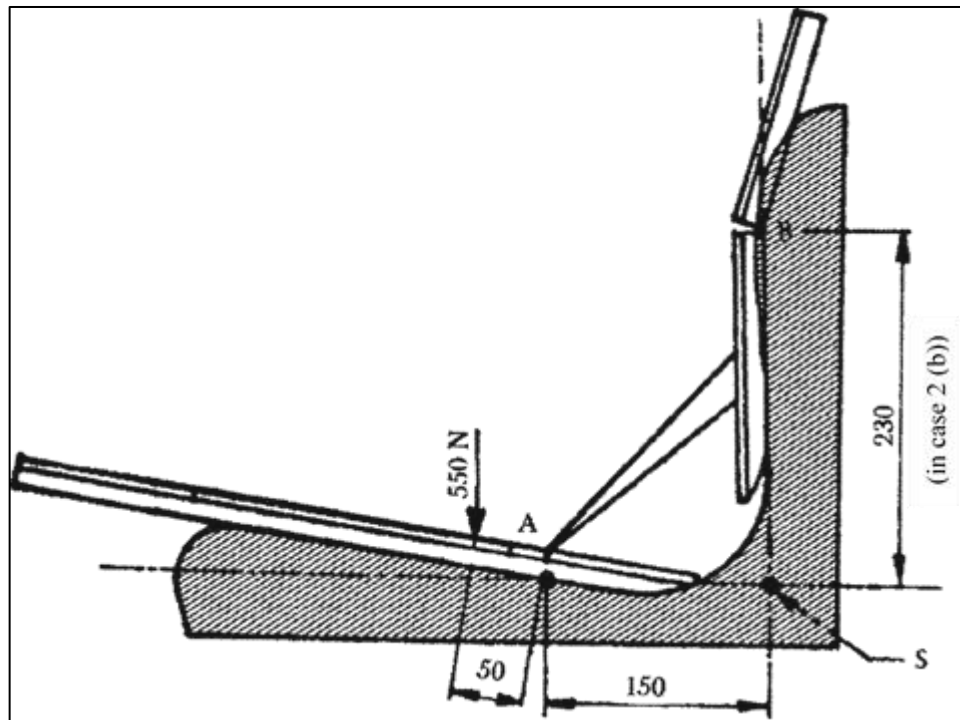

Figure 2

Device in position

ANNEX IV
(See introduction)
**COMPOSITION OF AISC PANEL ON
DRIVER-PERCEIVED NOISE LEVEL OF AGRICULTURAL AND
FORESTRY TRACTORS – METHOD OF MEASUREMENT***

Name	Organization
Convener	
Dr. N. H. Walke	The Automotive Research Association of India (ARAI)
Members	
Mr. D. S. Mole	The Automotive Research Association of India (ARAI)
Mr. Kamalesh Patil	The Automotive Research Association of India (ARAI)
Mr. Pradeep D. Jawale	The Automotive Research Association of India (ARAI)
Mr. Kirranpreet Aalag	International Centre for Automotive Technology (ICAT)
Ms. Rupali Lokhande	Central Institute of Road Transport (CIRT)
Mr. C. K. Tijare	Central Farm Machinery Training and Testing Institute (CFMTTI)
Mr. K. Dobrial	Northern Region Farm Machinery Training and Testing Institute (NRFMTTI)
Mr. Philip Koshy	International Tractors Ltd. (TMA)
Mr. Mohit Kumar	International Tractors Ltd. (TMA)
Mr. Mansingh Jagdale	John Deere India Pvt. Ltd. (TMA)
Mr. Ashish Mallarh	Kubota Agricultural Machinery India Pvt. Ltd. (TMA)
Mr. Nitin Jangra	Escorts Kubota Ltd. (TMA)
Mr. Pradeep Shinde	Mahindra & Mahindra Ltd. (TMA)
Mr. V. Venkatesan	Tractors and Farm Equipment Ltd. (TMA)
Mrs. Vasundhara Arde	Cooper Corporation Ltd. (TMA)
Mr. Sanjay Tank	Automotive Component Manufacturers Association (ACMA)

ANNEX V (See introduction)	
COMMITTEE COMPOSITION * Automotive Industry Standards Committee	
Chairperson	
Dr. Reji Mathai	Director, The Automotive Research Association of India
Members	Representing
Representative from	Ministry of Road Transport and Highways
Representative from	Ministry of Heavy Industries
Representative from	Office of the Development Commissioner, MSME, Ministry of Micro, Small and Medium Enterprises
Shri Shrikant R. Marathe	Former Chairman, AISC
Head-TED	Bureau of Indian Standards
Director	Central Institute of Road Transport
Director	Global Automotive Research Centre
Director	International Centre for Automotive Technology
Director	Indian Institute of Petroleum
Director	National Automotive Test Tracks
Director	Vehicles Research and Development Establishment
Director	Indian Rubber Manufacturers Research Association
Representatives from	Society of Indian Automobile Manufacturers
Representatives from	Tractor and Mechanization Association
Representatives from	Automotive Components Manufacturers Association of India
Representative from	Indian Construction Equipment Manufactures' Association
Member Secretary	
Shri Vikram Tandon	The Automotive Research Association of India