

AMENDMENT NO. 3* (05/2025)

to

AIS-135 Fire Detection and Alarm System (FDAS) & Fire Detection and Suppression Systems (FDSS) for Buses

** Amendment 3 to AIS-135, is prepared for including provisions for Fire Alarm requirement for Electric Buses.*

Amendment is re-issued with addition of date of implementation “1st October 2026” as decided in 65th meeting of CMVR-TSC.

1. Page III, INTRODUCTION

After fourth paragraph of introduction, insert following text

With increase in electrification in buses, need to have fire alarm requirement for Electric Buses was highlighted in 71st meeting of AISC held on 20th December 2023.

2. Page 1/35, clause 1.0

Substitute following text Scope for existing text of Scope

“1.0 SCOPE

1.1 This standard specifies the guidelines for detection and suppression systems for fires that may originate from engine compartment of buses and protection system from heat and smoke in occupant compartment.

In case of electric buses, relevant requirements of Fire Detection and Alarm Systems (FDAS) as per Part I for Battery Management System (BMS) compartment and Occupant compartment Fire Alarm Systems (FAS) as per Part III of this standard needs to be complied with.

1.2 This standard applies to

1.2.1 Part I – Fire Detection and Alarm Systems (FDAS)

Approval of Fire Detection and Alarm Systems (FDAS) which are fitted in engine compartment of Buses.

Approval of electric buses of Type I, Type II, Type III category and electric School buses in respect of their Fire Detection and Alarm System for BMS compartment.

In case of electric buses, compliance to thermal propagation test including audio-visual warning specified in AIS-038 (Rev.2) will be considered as deemed compliance to Part I requirements of this standard.

1.2.2 Part II – Fire Detection and Suppression Systems (FDSS)

Approval of Fire Detection and Suppression Systems (FDSS) which are fitted in engine compartment of Buses.

- 1.2.3 Part III – Occupant compartment Fire Alarm Systems (FAS) for school bus and buses of Type III category as per AIS-052 (Rev. 1) as amended from time to time. Approval of systems which are fitted in Buses to detect the presence of fire, smoke and /or heat in occupant compartment and provide alarm.

Approval of electric buses of Type I, Type II, Type III category and Electric School Buses in respect of their Occupant compartment Fire Alarm System.

- 1.2.4 Part IV – Occupant compartment Fire Protection Systems (FPS) for school bus and buses of Type III category as per AIS-052(Rev. 1) as amended from time to time.

Approval of systems which are fitted in Buses to protect the occupants from fire, heat and smoke to provide sufficient time for their safe evacuation.

- 1.3 Buses fitted with FDAS, FDSS, FAS and FPS shall comply with the requirements of this standard.

3. Page 1/35, after clause 2.0

Add following clause 3.0 and its sub-clauses after Clause 2.0

“3.0 In case of Occupant compartment Fire Alarm Systems (FAS) for Electric Buses following requirements are to be fulfilled

- 3.1 Application for type approval for compliance to Part III shall be as per Annex IA as applicable
- 3.2 In case of electric buses detectors shall be provided as specified in Part III of this standard. The fire shall be detected and warning signal shall be activated within 30 seconds after ignition. Based on internal experimental studies or simulations, it may vary, in such scenario dossier / documents shall be submitted by the manufacturer for validation to the testing agencies.
- 3.3 In case of electric fire in occupant compartment, provisions for automatic disconnection of wiring from Electric Source (auxiliary battery) may be provided. This requirement deemed to be met in case isolation switch is provided complying with requirements defined in Clause No. 5.4.5 of AIS-052 (Rev. 1) amended from time to time.

4. Part IV Cl. No. 5.2

Substitute following text for existing text of the clause

- “5.2 To obtain the requisite discharge rate condition, the protection system is to be assembled within its maximum piping limitations with respect to the number of fittings, size and length of pipe, if relevant. The water cylinder shall have applicable capacity or higher and appropriate pressure rating. The air cylinder or gas cartridge pressurized with propellant gas or suitable technology is expected to achieve constant operating pressure, with the help of adjustable pressure reducing valve, or any suitable mechanism, for at least 180 seconds or higher. The material of construction for components in contact with water shall be SS304 or better. For water cylinder, alternatively any other suitable composite material may be used and water cylinder with composite material shall comply with the below requirements.
- a. Tensile strength – minimum 1200 MPA as per ASTM D2343-08 or Equivalent ISO.
 - b. Burst Pressure – minimum 55 bar as per ISO 11119-03.
 - c. Flammability requirement as per IS 15061:2002 and
 - d. Fire and Flame protection (bone fire test) as per ISO 11119-3.”

PRINTED BY
THE AUTOMOTIVE RESEARCH ASSOCIATION OF INDIA
P. B. NO. 832, PUNE 411 004

ON BEHALF OF
AUTOMOTIVE INDUSTRY STANDARDS COMMITTEE
UNDER

CENTRAL MOTOR VEHICLES RULES - TECHNICAL STANDING
COMMITTEE

SET-UP BY
MINISTRY OF ROAD TRANSPORT & HIGHWAYS
GOVERNMENT OF INDIA

7th May 2025

AMENDMENT NO. 2 (09/2023)

TO

AIS-135 Fire Detection and Alarm System (FDAS) & Fire Detection and Suppression Systems (FDSS) for Buses

1. PART III Cl. No. 4.2

Substitute following text for existing text of the clause

“4.2 Upon detection of fire in occupant compartment, the system referred in clause no 4.1, shall provide the driver and passengers with both an acoustic and a visual signal, and activate the hazard warning signal. The placement of the visual signal shall be such that it is visible unobstructed while viewed from the driver seat in any direction. In case of obstruction, driver shall be provided with an additional visual signal.

2. Part IV, Clause 4.5.3

Substitute following text for existing text of the clause

“4.5.3 Further analysis shall also be conducted prior to the installation of FPS in order to determine the location and direction of suppression agent discharge point(s) (e.g. nozzles, type or water mist discharge tube or other Distribution points). Potential fire hazards within the occupant compartment and each sub-compartment where a fire risk is present shall be identified as per clause 4.5.2 and discharge point(s) located such that the water mist is distributed to cover the fire hazard when the system activates. The spray pattern and direction of discharge points as well as the throwing distance shall be ensured to cover identified fire hazards. Method of ensuring operation of system under vehicle attitude, road conditions etc. shall be included in analysis report by vehicle manufacturer.”

3. Part IV, Cl. No. 4.5.6

Substitute following text for existing text

“4.5.6 The design features of the any FPS system shall be based on maximum volume in the applicable gross volume range. Accordingly, design parameters i.e. the minimum number of discharge points / nozzles and quantity of stored water as suppression agent are provided in 4.5.5 above. The pressure of the propellant gas shall be operated to achieve 8.0 ± 1.0 bar nozzle operating pressure at all discharge points. During testing, pressure may be measured at farthest discharge points ensuring 8.0 ± 1.0 bar.

The nozzles used shall meet the following characteristics at 7.0 bar i.e. minimum design operating pressure of FPS.

Nozzle Flow Rate	:	1.75 ± 0.5 Litres per minute
Cone Angle	:	90° or higher, solid cone
Polydisperse Droplet Sizes		
D ₃₂ (Sauter Mean Diameter)	:	180 micrometre or lower
Dv90 (Droplet size for 90% of the volume faction)	:	300 micrometre or lower

”

4. Part IV, Cl. No. 5.3

Substitute following text for existing text

“5.3 The fire protection system shall be installed by the system manufacturer or supplier based on as-built drawing to show the area where fire suppression agent discharge points such as of nozzles, fire suppression agent cylinder or fire suppression agent discharge tubes are located. The discharge points are recommended to be positioned inside occupant compartment along the length of the bus, angled downwards or in such a way to provide wet coverage to side windows and seats located just below, as the case may be in three different headers. Selection of number of nozzles shall be based on gross volume of the bus using table mentioned in Cl. No. 4.5.5 of Part IV.

- a. Above the windows on right side (RS) of the occupant compartment on the ceiling or just below the luggage rack.
- b. On the ceiling of gang way i.e. mid-section (MS), upto 1.5 times the spacing being used in RS discharge points.
- c. Above the windows on ‘Left Side’ (LS) of the occupant compartment, on the ceiling or just below the luggage rack with an offset upto 750 mm from similar installations on the RS, wherever possible.

Sr. No.	Seating Capacity	Gross Volume Range (m ³)	No of Nozzles RS	No of Nozzles MS	No of Nozzles LS
1.	20	Less than 20	3	3	3
2.	30	20 to 30	5	4	4
3.	40	30 to 40	7	5	6
4.	50	40 to 50	8	7	7
5.	60	50 to 60	9	8	9
6.	70	60 to 70	11	9	10
7.	80	70 to 80	13	10	12

”

5. Annex IVA, Cl. No. 2.3

Substitute following text for existing text

“2.3 The audio-visual alarm unit and control panel, shall have ingress level protection of IP54 or higher. Control panel shall be positioned in a conspicuous position in the vicinity and accessible to the driver. Additional audio-visual alarm unit may be installed at the rear of occupant compartment, if required.”

6. Annex VA, Note

Substitute following Note for existing Note

“**Note:-** For components level recommended tests for Fire Protection System (FPS), please refer clause no. 4.0 of Appendix 7.”

7. Annex VIA, Cl. No. 3.4

Substitute following text for existing text

“3.4 The audio-visual alarm unit and control panel, shall have ingress level protection of IP54 or higher. Control panel shall be positioned in a conspicuous position in the vicinity and accessible to the driver. Additional audio-visual alarm unit may be installed at the rear of occupant compartment, if required.”

8. Annex VIIA, Cl. No. 4.1

Substitute following text for existing text

“4.1 The FPS shall be capable to be remotely activated from control panel positioned in a conspicuous position in the vicinity and easily accessible to the driver, through electrically operated solenoid valve either on confirmation of fire or immediately after receiving Audio-visual Signal from Fire Alarm System.”

9. ANNEX VIII, GUIDELINES FOR DECIDING WHETHER TESTING IS NEEDED, Clause No. 3.

Substitute following clause No. 3 for existing clause No. 3

“3. In the case of following changes, with respect to the vehicles tested, in the details submitted as per Annexures IA & IIA tests are necessary for establishing compliance:

1	Change in gross volume of the bus	Test shall be conducted on one occupant compartment in the minimum gross volume range and on one occupant compartment in the maximum gross volume range, as declared by the manufacturer from Sr. No. 1 to Sr. No. 7 of clause 4.5.5 of Part IV to establish compliance, provided there are no changes in approved design parameters such as Nozzles, pressuring system, detectors, control panel, pipe size, pressure reducing valve etc.
2	Change in water capacity of fire suppression system.	Compliance with Part IV to be tested.
3	Dimensions of pipes.	Compliance with Part IV to be tested, if there is any change in inner diameter of the pipes.
4	Change in Pressurized dry air cylinder	Compliance with Part IV to be tested in case of decrease in stipulated pressure and/or capacity.
5	Type and characteristics of the nozzles.	Compliance with Part IV to be tested.
6	Type of solenoid valve, pressure regulating valve, safety / relief valve.	Compliance with Part IV to be tested.
7	Type of detector in FAS or number of detection zones	To be verified for compliance with Part III

10. Appendix 6, Clause 4.1, S. No. 8

Substitute following S. No. 8 for existing S. No. 8

8.	Nozzle Characterization – three parameters in Clause 4.5.6 Part IV for each nozzle.	Certification from Test agencies /BIS/NABL recognized lab /CFEES
----	---	--

11. Appendix 6, Cl. No. 4.3

Substitute following text for existing text

“4.3 Functional Test of FPS are intended for checking flow characteristics of installed Fire Protection System. As mutually agreed between manufacturer and test agency, discharge points are loosely wrapped (to allow air to escape) with 10 liters capacity plastic bag to collect the water during 3 minutes of system operation.

Time	Action
00:00	Start FPS
00:10	FPS activation confirmation
03:10	Manual switch off of FPS
* Time in seconds for system operation, normal operational pressure and water volume at discharge points as mutually agreed between manufacturer and test agency, in liters, shall be recorded in the test report.	

12. Appendix 7, Clause 4.2, B Mechanical Shock Test, Acceleration

Substitute following text for existing text on Acceleration

Acceleration : 10g

PRINTED BY

THE AUTOMOTIVE RESEARCH ASSOCIATION OF INDIA
P. B. NO. 832, PUNE 411 004

ON BEHALF OF
AUTOMOTIVE INDUSTRY STANDARDS COMMITTEE

UNDER
CENTRAL MOTOR VEHICLES RULES - TECHNICAL STANDING
COMMITTEE

SET-UP BY
MINISTRY OF ROAD TRANSPORT & HIGHWAYS
(DEPARTMENT OF ROAD TRANSPORT & HIGHWAYS)
GOVERNMENT OF INDIA

5th September 2023

AMENDMENT No. 1 (01/2022)

TO

AIS-135 Fire Detection and Alarm System (FDAS) & Fire Detection and Suppression Systems (FDSS) for Buses

1. Page III, INTRODUCTION

After first paragraph of introduction, insert following text

Under the guidance of the Ministry of Road Transport and Highways (MORTH) and project proposal based on experiments carried out by DRDO (CFEES) for introduction of protection of occupants from fire, panel under Automotive Industry Standards Committee (AISC), has prepared this amendment to notified standard AIS-135.

Presently fire detection, alarm and suppression systems are notified for fires originating from engine compartment vide AIS-135. Provisions regarding protection of occupants from fire under this amendment are aimed at providing an additional evacuation time to the occupants and thus will further enhance the safety in fire incidents in buses through FPS and FAS.

A significant majority of fatal and non-fatal injuries to passengers in bus fire accidents on Indian roads are due to heat and / or smoke in passenger compartment irrespective of origin of fire in the vehicle. The fatal and non-fatal injuries to passengers in bus fire accidents on Indian roads can be prevented if, irrespective of origin of fire in the vehicle, the heat and smoke in occupant compartment is controlled and thus providing an evacuation window to the occupants. In amendment 1 smoke and heat detectors are specified. However, other better detectors (e.g. CO or UV detectors) are also allowed. Also over and above of protection specified in standard additional protection may be provided at the choice of manufacturer.

2. Page 1/35, clause 1.0

Substitute following text Scope for existing text of Scope

“1.0 SCOPE

1.1 This standard specifies the guidelines for detection and suppression systems for fires that may originate from engine compartment of buses and protection system from heat and smoke in occupant compartment.

1.2 This standard applies to

1.2.1 Part I – Fire Detection and Alarm Systems (FDAS)

Approval of Fire Detection and Alarm Systems (FDAS) which are fitted in engine compartment of Buses.

1.2.2 Part II – Fire Detection and Suppression Systems (FDSS)

Approval of Fire Detection and Suppression Systems (FDSS) which are fitted in engine compartment of Buses.

- 1.2.3 Part III – Occupant compartment Fire Alarm Systems (FAS) for school bus and buses of Type III category as per AIS-052 (Rev. 1) as amended from time to time.

Approval of systems which are fitted in Buses to detect the presence of fire, smoke and /or heat in occupant compartment and provide alarm.

- 1.2.4 Part IV – Occupant compartment Fire Protection Systems (FPS) for school bus and buses of Type III category as per AIS-052(Rev. 1) as amended from time to time.

Approval of systems which are fitted in Buses to protect the occupants from fire, heat and smoke to provide sufficient time for their safe evacuation.

- 1.3 Buses fitted with FDAS, FDSS, FAS and FPS shall comply with the requirements of this standard.

- 1.4 The requirements of this standard shall not be applicable for Electric Powertrain Vehicles (EVs).”

3. Page 1/35, clause 2.0

Add following clauses 2.7 to 2.9 after clause 2.6

- 2.7 UL – 268 UL Standard for Safety Smoke Detectors for Fire Alarm Systems
2.8 EN 54/22 Fire detection and fire alarm systems. Resettable line-type heat detectors
2.9 EN 54/20 Fire detection and fire alarm systems. Aspirating Smoke detectors
2.10 IS 15519:2004 Water Mist Fire Protection Systems-System Design, Installation and Commissioning-Code of Practice.

4. Page 5/35, Part II

Add following Parts III and IV after Part II

“PART III Requirements of Fire Alarm Systems (FAS) for bus occupant compartment

1.0. DEFINITIONS

For the purpose of Part III of this standard,

- 1.1 **Fire Alarm System (FAS)** - A system comprising of components and sub-systems required for automatically detecting fire, heat and /or smoke in occupant compartment and initiating an automatic alarm.
- 1.2. **Occupant Compartment** - for the purpose of this standard occupant compartment means the compartment / space inside a vehicle designed for occupant occupancy including driver’s seating area.

- 1.3. **Fault Signal** - A distinctive audible and visual signal indicating occurrence of a fault within the FAS (for example, break in electric circuit, short circuit or fault in power supply, mechanical damage in detector or elsewhere in system).
- 1.4. **Alarm Signal** - An audio and visual signal initiated by a smoke or CO or Heat alarm-initiating device, such as a fire alarm box, automatic fire detector, or other device in which activation is indicative of the presence of a smoke or gas or heat as fire signature.
- 1.5. **Fire detection system type** - for the purpose of type approval as a component means a category of systems which does not essentially differ in the following aspects:
- a) Detection system;
 - b) Detector;
 - c) ECU (ECU/Control Panel may be common for FDAS/ FDSS/ FAS/ FPS).
- 1.6. **Smoke**- The airborne solid and liquid particulates along with gases evolved due to pyrolysis or combustion of materials, together with the quantity of air that is entrained or otherwise mixed into the mass.
- 1.7. **Heat Detector** - A heat detector is a sensor that senses either abnormally high temperature or rate of temperature rise, or both, coupled with smoke detector.
- 1.8. **Smoke Detector** - A smoke detector is a sensor that senses the presence of significant amount of smoke as fire signature.
- 1.9. **Class A Fire** – A fire in occupant compartment involving all possible ordinary solid combustibles present there.
- 1.10. **False Alarm**: A false alarm, is the deceptive or erroneous signal of an emergency, causing unnecessary panic and/or involvement of specialized resources when they are not needed.
- 1.11 **Carbon Monoxide** - Carbon monoxide (CO) is an invisible, odorless gas. It is a common by-product of incomplete combustion, produced when fossil fuels (like oil, gas or coal) burn.
- 1.12 **Carbon Monoxide Detector** - A carbon monoxide detector or CO detector is a device that detects the presence of the carbon monoxide gas as fire signature.
- 2.0. APPLICATION FOR CMVR APPROVAL**
- 2.1. Application for CMVR type approval for a vehicle type in respect of the Fire Alarm Systems (FAS) in Occupant Compartment of buses.
- 2.1.1. The application for approval of:
- (a) A vehicle type or;
 - (b) A vehicle type fitted with bodywork type approved as a technical unit.
 - (c) A component type with regard to its constructional features shall be submitted by the manufacturer or by his duly accredited representative.

- 2.1.2. It shall be accompanied by the documents containing the information specified in Annex IA & IIIA as applicable.
- 2.1.2.1. Detailed description of the vehicle type with regard to the arrangement and design of the control or of the unit on which the fire alarm system acts.
- 2.1.3 A vehicle representative of the type to be approved shall be submitted to the approval agency.
- 2.1.4 A vehicle not comprising all the components proper to the type may be accepted provided that it can be shown by the applicant to the satisfaction of the approval agency that the absence of the components omitted has no effect on the results of the verifications, so far as the requirements of this standard are concerned.
- 2.1.5 In case of application for approval of a type of vehicle, the manufacturer shall also provide the following information about installed FAS:
 - 2.1.5.1 A copy of the analysis regarding the installation of the FAS (see Annex IVA) in case FAS is approved as a component, or
 - 2.1.5.2 An analysis on regarding the installation of the FAS (see Annex VIA) in case FAS is installed in a specific occupant compartment.

3.0 MODIFICATION AND EXTENSION OF APPROVAL OF A VEHICLE OR BODYWORK TYPE

- 3.1 Every modification of the vehicle, bodywork type or fire alarm system shall be notified to the test agency which approved the type. That test agency may then determine that: (see Annex VIII)

Either that the modifications made are unlikely to have an appreciable adverse effect and that, in any case, the vehicle, bodywork or fire detection system still complies with the requirements; Or require a further test of compliance from the manufacturer.

4.0. GENERAL REQUIREMENTS

- 4.1 Vehicles shall be equipped with fire alarm system detecting fires in the occupant compartment based on sensors that get provide a signal of presence of fire either through smoke or abnormally high temperature / rate of temperature rise, or both or light (infrared, visible, ultraviolet) emitted by flames during combustion. The smoke or CO detectors when forming part of FAS shall have dust compensation feature and conform to relevant IS/UL/FM / Global Standard / LPCB/VdS/EN 54.
- 4.2 Upon detection of fire in occupant compartment, the system referred in clause no 4.1, shall provide the driver and passengers with both an acoustic and a visual signal, and activate the hazard warning signal. The placement of the visual alarm shall be such that it is visible unobstructed while viewed from the driver seat.
- 4.3 The occupant compartment fire alarm system shall be operational irrespective of whether engine has been started and the vehicle's attitude.

- 4.4 The installation of the fire alarm system shall comply with the following requirements;
- 4.4.1. The fire alarm system shall be installed according to the system manufacturer's installation manual.
- 4.4.2 An fire risk analysis shall be conducted prior to the installation in order to determine the location of fire detectors. Potential fire hazards within the occupant compartment shall be identified such that the fire detectors shall be positioned to appropriately cover the fire hazard. The system shall also be ensured to work properly regardless of the vehicle's attitude, road conditions etc.
- 4.5. Minimum sound level of audio-visual alarm shall be 90 dB(A) to make it audible to the passenger seated on rear seats of the bus. Optionally hooter system as approved under AIS-052(Rev. 1) can be used with minimum sound level of 90 dB(A). Hooter may be common with FDAS/FDSS.
- 4.6 Further, to the FAS required in the occupant compartment by this standard, the additional heat sensors to monitor temperature near fuel tank and/or near wheel braking system may be installed as enhanced fire safety measures.

PART IV

Approval of Bus Occupant Compartment Fire Protection System (FPS)

1.0. DEFINITIONS

For the purpose of Part IV of this standard,

- 1.1 Fire Protection System (FPS): Fire Protection System is a low pressure water mist system comprising of necessary elements to manually trigger release of water mist, with specific characteristics, capable of suppressing the designed class A fire in occupant compartment as well as controlling the temperature inside the occupant compartment, when origin of fire is not occupant compartment, to provide atleast three minutes of evacuation window to the occupants.
- 1.2 "Approval of a vehicle, or a separate technical unit or a component" means the approval of a vehicle type, or of bodywork or of a component type with regard to the constructional features specified in this Standard;
- 1.3 "Fire Protection System" for the purpose of type approval as a component means a category of bus systems which does not essentially differ in the following aspects:
- (a) Compartment(s) for passengers including drivers' cabin;
 - (b) Maximum gross volume upto 80m³;
 - (c) General layout of components in the compartment (i.e. position of fire hazards determined and limited to maximum no of seats for a given volume).
 - (d) Marking of exit routes, combustion heater and engine on the layout

- (e) Number and type of fire suppression agent discharge point(s) (e.g. nozzle/mist generator atomizer) used ;
 - (f) Stored dry air as propellant gas or alternative mechanism, including pump (if fitted), to generate desired water pressure at discharge point."
- 1.4. 'Occupant Compartment' means the compartment / space inside a vehicle designed for passenger occupancy including driver's cabin, if any.
 - 1.5. Water Mist System –A distribution system connected to a water cylinder as atomizing media through suitable number of nozzles capable of delivering water mist that meets the performance requirements as per this standard.
 - 1.6. Propulsion System – a system when activated shall be able to provide water in the piping network at constant nozzle operating pressure for specific time either using air propulsion system including high pressure air cylinder, pressure regulating valve and solenoid valve or any such similar arrangement.
 - 1.7. Pressure Relief Valve - A device designed to prevent pressure levels in excess of the design pressure of the system and/or, the system components.
 - 1.8. Low Pressure System. A water mist system where the water distribution piping is exposed to pressures of 12.1 bar (175 psi) or less.

2.0. APPLICATION FOR CMVR APPROVAL

- 2.1 The application for approval of:
 - (a) A vehicle type with fire risk analysis or;
 - (b) A separate technical unit type or;
 - (c) A vehicle type fitted with bodywork type already approved as a separate technical unit as per this part of the standard with type approval of all its components type with regard to its constructional features working at higher than atmospheric pressure shall be submitted by the manufacturer or by his duly accredited representative.
- 2.2 It shall be accompanied by the documents containing the information specified in Annex IIA and IIIA.
- 2.3 Detailed description of the vehicle type with regard to the arrangement and design of the control or of the unit on which the fire protection system acts.
- 2.4 A vehicle or fire protection system representative of the type to be approved shall be submitted to the test agency.
- 2.5 A vehicle not comprising all the components proper to the type may be accepted provided that it can be shown by the applicant to the satisfaction of the test agency that the absence of the components omitted has no effect on the results of the verifications, so far as the requirements of this standard are concerned.
- 2.6 In case of application for type approval of a bus, the manufacturer shall also provide the following information regarding the occupant compartment fire protection system, if applicable:
 - 2.6.1 A copy of the analysis on regarding the installation of the FPS in case of a fire protection system (FPS) approved as a component (see Annex VA) or

2.6.2 An analysis on regarding the installation of the FPS in case of a fire protection system (FPS) installed in a specific occupant compartment, (see Annex VIIA)

3.0. MODIFICATION AND EXTENSION OF APPROVAL OF A VEHICLE OR BODYWORK TYPE

3.1 Every modification of the vehicle, bodywork type or fire protection system shall be notified to the test agency which approved the type. That test agency may then determine that: (see Annex VIII)

Either that the modifications made are unlikely to have an appreciable adverse effect and that, in any case, the vehicle, bodywork or fire suppression system still complies with the requirements; Or require a further test of compliance from the manufacturer.

4.0. GENERAL REQUIREMENTS

4.1 The requirements of this Part of the standard have been formalized based on the evaluation of the efficacy of water mist system in occupant compartment of standard size bus, in case of

- a. Seat surface fire inside the occupant compartment where the suppression is achieved through experiments.
- b. External fire affecting occupant compartment of buses, where cooling and scavenging is achieved, in simulation studies, to ensure an evacuation window of at least three minutes to the occupants.

4.2 In the buses irrespective of having engine located either to the front or rear, the occupant compartment shall be equipped with a fixed fire protection system for life safety of occupants. Thus providing the driver an option to use fire fighting system to flood the compartment with water mist to control the temperature and smoke inside the occupant compartment for a defined period of time. This time window shall be used for evacuation of passengers to safety. The hazard warning signal include acoustic and a visual signal indicting presence of fire/smoke or event of sensing either abnormally high temperature or rate of temperature rise, or both, in the occupant compartment or in each sub-compartments, as the case may be.

4.3 In addition to the fire alarm system, vehicles shall be equipped with a fire protection system in the occupant compartment as well as in each sub-compartments within the occupant compartment.

4.4 The fire alarm system and the fire protection system shall be operational irrespective of whether engine is running or not and the vehicle's attitude. This is to ensure availability of FPS in the case of external fire which is expected to be the most likely cause of transfer of heat and smoke to occupant compartment. The external fire sources i.e. not originated in occupant compartment, are fires such as in engine, fuel tank or in braking system with or without involvement of collision.

4.5 Before finalizing the design and installation details of the FPS, an assessment of fire risk within the occupant area shall be completed.

4.5.1 For standard bus designs, the primary risk of heat and smoke to occupants from within the compartment emanates from ignition of class 'A' materials present

in the form of solid combustibles (wood, fiber boards, seat cushions/foams, curtains, upholstery etc.) and the total quantity is expected to be proportional to the number of seats. Excessive loading of combustible material inside the occupant compartment may have adverse impact on expected performance of FPS. The risk analysis shall be documented with approximate quantities of the each source as per clause 4.5.2 below.

- 4.5.2 The analysis shall take into account at-least the following:
- a. amount of each Class A fire source spread over the compartment,
 - b. identification of surfaces where temperatures may reach above 80°C (due to the auto-ignition temperature for fluids, gases or substances in contact with the surfaces and electrical components and cables with a current or voltage high enough for an ignition to occur as well as hoses and containers with flammable liquid or pressurized gas).
- 4.5.3 Further analysis shall also be conducted prior to the installation of FPS in order to determine the location and direction of suppression agent discharge point(s) (e.g. nozzles, type or water mist discharge tube or other distribution points). Potential fire hazards within the occupant compartment and each sub-compartment where a fire risk is present shall be identified as per clause 4.5.2 and discharge point(s) located such that the water mist is distributed to cover the fire hazard when the system activates. The spray pattern and direction of discharge points as well as the throwing distance shall be ensured to cover identified fire hazards. The system shall also be ensured to work properly regardless of the vehicle’s attitude, road conditions etc.
- 4.5.4 A low pressure system comprising of atomizer/nozzles, piping network, water cylinder mounted with pressure relief valve if fitted, and connected to water propulsion system to generate fine mist of desired size and concentration for specified time is to be installed in the occupant compartment.
- 4.5.5 The design of FPS comprising of water mist system is recommended to be based on 0.65 LPM/m³ mist injection rate and accordingly the technical features with respect to different volume of occupant compartment have been arrived as per the table given below. The “seating capacity” is used as an indication of standard fire load. The highest volume in “gross volume range” of the occupant compartment is used as a basis for system design for FPS implementation. When measuring the gross volume of occupant compartment, the range shall be arrived without subtracting the volume of installed components / seats etc. from it. Selection of number of nozzle and water quantity shall be based on gross volume of the bus using following table as a reference.

S. No.	Seating Capacity (Maximum)	Gross Volume Range (m ³)	No of Nozzles (Minimum)	Water Quantity (Liters)
1.	20	Less than 20	9	55
2.	30	20 to 30	13	80
3.	40	30 to 40	18	110
4.	50	40 to 50	22	130
5.	60	50 to 60	26	155
6.	70	60 to 70	30	185
7.	80	70 to 80	35	210

- 4.5.6 The design features of the any FPS system shall be based on maximum volume in the applicable gross volume range. Accordingly, design parameters i.e. the minimum number of discharge points / nozzles and quantity of stored water as suppression agent are provided in 4.5.5 above. The pressure of the propellant gas shall be operated to achieve 8.0 ± 1.0 bar nozzle operating pressure at all discharge points. The nozzles used shall meet the following characteristics at 7.0 bar i.e. minimum design operating pressure of FPS.

Nozzle Flow Rate	:	1.75 ± 0.5 Litres per minute
Cone Angle	:	90° or higher, solid cone
Polydisperse Droplet Sizes		
D ₃₂ (Sauter Mean Diameter)	:	180 micrometre or lower
Dv90 (Droplet size for 90% of the volume faction)	:	300 micrometre or lower

- 4.5.7 The discharge of water as extinguishing agent shall be along the length of the bus, in three headers, in such a way that mist is targeted to the seats on left side, right side with the nozzle spacing upto 1500 mm as well as on the mid-section of the ceiling for cooling of smoke layer, as per clause 5.0 for installation of water mist system. The total discharge time of the system shall not be less than THREE minutes. It is acceptable if the suppression system has more quantity of fire suppression agent and/or more discharge points and/or a longer discharge tube for the extinguishing agent and/or more propellant gas than required according to the table given in clause 4.5.5.
- 4.5.8 The manual activation of system through control panel, having independent power backup or auxiliary power back-up or through vehicle bypass power supply for mandatory emergency functions as the case may be, will be positioned in the vicinity of the driver's dashboard, in such a manner that the driver based on one or more of the following inputs, shall be able remotely activate the FPS through electrically operated solenoid valve on confirmation of unmanageable fire in occupant compartment after receiving an audio-visual signal from Fire Alarm System or self-observation / input from others about presence of an external fire that may affect the lives of bus occupants.
- 4.5.9 For ensuring effectiveness of FPS in a non-air conditioned bus, where 50% of the windows are expected to be open at any given time, the water mist injection rate has been kept in the range 0.65 litres per m³ per minute or higher. When applied to an air-conditioned bus the same level of mist injection rate shall provide additional factor of safety.

5.0 INSTALLATION REQUIREMENTS

- 5.1 The fire protection system shall be installed according to the system manufacturer's installation manual.
- 5.2 To obtain the requisite discharge rate condition, the protection system is to be assembled within its maximum piping limitations with respect to the number of fittings, size and length of pipe, if relevant. The water cylinder shall have applicable capacity or higher and appropriate pressure rating. The air

cylinder or gas cartridge pressurized with propellant gas or suitable technology is expected to achieve constant operating pressure, with the help of adjustable pressure reducing valve, or any suitable mechanism, for at least 180 seconds or higher. The material of construction for components in contact with water shall be SS304 or better.

5.3 The fire protection system shall be installed by the system manufacturer or supplier based on as-built drawing to show the area where fire suppression agent discharge points such as of nozzles, fire suppression agent cylinder or fire suppression agent discharge tubes are located. The discharge points are recommended to be positioned inside occupant compartment along the length of the bus, angled downwards or in such a way to provide wet coverage to window and seats located just below, as the case may be, in three different headers:

- a. Above the windows on right side (RS) of the occupant compartment on the ceiling or just below the luggage rack.
- b. On the ceiling of gang way i.e. mid-section (MS), upto 1.5 times the spacing being used in RS discharge points.
- c. Above the windows on 'Left Side' (LS) of the occupant compartment, on the ceiling or just below the luggage rack with an offset upto 750 mm from similar installations on the RS, wherever possible.

SNo.	Seating Capacity	No of Nozzles		
		RS	MS	LS
1.	20	3	3	3
2.	30	5	4	4
3.	40	7	5	6
4.	50	8	7	7
5.	60	9	8	9
6.	70	11	9	10
7.	80	13	10	12

5.4 The number of discharge points in each LS and RS section shall depend upon number of seats on each side. Any deviation from the table at clause 5.3 above be justified and recorded. The system set-up and configuration shall be observed and documented e.g. amount of suppression agent and propellant gas, system pressure, number, type and location of discharge points, length of pipes and number of fittings.

5.4.1 Pipe layout network from water cylinder to distribution manifold for connecting all three headers consisting atomizers to be optimized for pressure drop.

5.4.2 The pipe network shall be welded / bolted securely at sidewalls or ceiling of the compartment with support brackets and clamps. The pipe distribution network shall be installed in such a way so that the entire working fluid in the pipe network can be easily drained and ease of refilling is achieved.

5.4.3 After installation of the pipe distribution work, the pipe work shall be hydrostatically tested as per IS 15519 and performance shall be documented for review of approval agency.

6.0 LIMITATION

The design features elaborated in clause 4 & 5 above are applicable to the standard bus of volume and seat matrix i.e. upto 80m³ and having 80 number of seats. The buses having special comfort arrangements or sub-compartments in occupant area shall be subject to simulated fire tests as per Appendix 6.”

5. Page 8/35, Annex I

Add following Annex IA after existing Annex I

ANNEX IA
(See Part III, clause 2.1.2)

INFORMATION TO BE SUBMITTED FOR TYPE APPROVAL OF BUSES WITH REGARD TO FIRE ALARM SYSTEM (FAS)

S. No	Parameter	
1.	Name of the Model(s)	
2.	Variant(s)	
3.	Vehicle category (s)	
4.	Name and address of vehicle manufacturer	
5.	Type of fire detector(s) used	
6.	Number of fire detector (s) for each type	
7.	Name and address of manufacturer of the Fire detectors for each type	
8.	Name and address of manufacturer of the alarm system and control panel	
9.	Description of the device installation and sketch showing locations within occupant compartment and relevant dimensions of fire detectors	
10.	Detection Devices provided additionally Acoustic or visual If visual, duration and type of optical signal	
11.	Test report number of the FAS	

6. Page 9/35, Annex II

Add following Annex IIA after existing Annex II

ANNEX II A
(See Part IV, clause 2.2)
INFORMATION TO BE SUBMITTED FOR TYPE APPROVAL OF BUSES
WITH REGARD TO FIRE PROTECTION SYSTEM

S. No	Parameter	
1.	Name of the Model(s)	
2.	Variant(s)	
3.	Vehicle category(s)	
4.	Dimensions of the occupant compartment	
5.	Name and address of vehicle manufacturer	
6.	Make and type of the fire protection system	
7.	Test report number of the FPS	
8.	Water reservoir max operational pressure (kg/cm ²):	
9.	Quantity of fire suppression agent (deionized water in litre):	
10.	Numbers and characteristics of discharge point(s):	
11.	Total Length of discharge tube in occupant compartment	
12.	Number of discharge points(s):	
13.	Type of propellant gas, dry air cylinder:	
14.	Stored pressure of propellant gas (dry air)	
15.	Minimum operating temperature	
16.	Dimensions of pipes and fittings	
17.	Detailed description, layout drawings and installation manual of the fire suppression system and its components	

7. Page 10/35, Annex III

Add following Annex IIIA after existing Annex III

“ ANNEX III A
(See Part III clause 2.1.2, and Part IV clause 2.2)
INFORMATION TO BE SUBMITTED FOR COMPONENT LEVEL
APPROVAL OF FIRE ALARM SYSTEM AND FIRE PROTECTION
SYSTEM

S. No	Parameter	
1.	Make (trade name of manufacturer):	
2.	Type and general commercial description:	
3.	Name and address of manufacturer:	
4.	Type and numbers fire detector(s) used	
5.	Name and address of manufacturer of the Fire detectors	
6.	Description of the device or sketch showing location, relevant dimensions of fire detectors	
7.	Devices provided additionally Acoustic or visual If visual, duration and type of optical signal	
8.	Water mist system (make and type of key components):	
9.	Quantity of fire suppression agent (Water):	
10.	Type & characteristics of nozzles/discharge point(s):	
11.	Total length of discharge tube in occupant compartment	
12.	Number of discharge points(s):	
13.	Type of propellant gas (dry air) cylinder:	
14.	Stored pressure of propellant gas (dry air)	
15.	Minimum operating temperature	
16.	Dimensions of pipes and fittings	
17.	Detailed description, layout drawings and installation manual of the fire protection system and its components	
18.	Test report no. complying to IS/FM/UL standard for each component supplier	

”

8. Page 11/35, Annex IV

Add following Annex IVA after existing Annex IV

“ANNEX IVA
(See Part III, Clause 2.1.5.1)
REQUIREMENTS FOR FIRE ALARM SYSTEM (FAS)
APPROVED AS A COMPONENT

1.0. Specifications

- 1.1 Fire Alarm System (FAS) conforming to this standard shall comply with the requirements of class A fire and smoke test described in Appendix 6.
- 1.2 The test apparatus, class A smoke and fire test and general test conditions are described in Appendix 6 to test the response time of FAS.

2.0. Requirements

- 2.1 The detectors forming part of FAS shall conform to relevant IS / UL / FM-Global Standard. The number of detectors shall be sufficient in numbers that when mounted in the occupant compartment, with or without partition, will be line of sight to at least one detector from every class A fire source present in the occupant compartment, when the bus is empty. This is to ensure optimal coverage of threats of fire liable to break out in the occupant compartment.
- 2.2 The numbers of detectors in any FAS may be higher or lower for special sensors such as multi-sensor type, linear type, aspirating type to meet the criteria mentioned in paragraph 2.5 below.
- 2.3 The audio-visual alarm unit and control panel, having ingress level protection of IP54 or higher, will be positioned in the vicinity of the driver’s dashboard. Additional audio-visual alarm unit may be installed at the rear of occupant compartment, if required.
- 2.4 In addition, provision for manual means of activation of audio-visual alarm may be incorporated in the control panel as an option.
- 2.5 The fire shall be detected and warning signal shall be activated within 30 seconds after ignition of test fire #8.
- 2.6 The test is considered passed if success was achieved at the first attempt or at two of three attempts in a case when first of these attempts fails.”

9. Page 12/35, Annex V

Add following Annex VA after existing Annex V

“ANNEX V A
(See Part IV, clause 2.6.1)

**REQUIREMENTS FOR FIRE PROTECTION SYSTEM
(FPS) APPROVED AS A COMPONENT**

1.0. Specifications

- 1.1. Fire protection System (FPS), conforming to this standard, as a component, shall comply with the requirements of Part IV of this standard.
- 1.2. The test apparatus for functional test, evaluation of design and documentation are described in Clause 4.0 of Appendix 6.

2.0. Requirements

- 2.1 The FPS system key components are type tested and meet all the requirement of safety, design and operation from this standard to achieve the service requirements.
- 2.2 The FPS to be tested for appropriate occupant compartment and to be activated remotely/manually through an electrical switch positioned in the vicinity of the driver’s dashboard, to actuate the connected solenoid valve or pumping device to perform one or more functional tests in Appendix 6.
- 2.2 The FPS is expected to achieve intended purpose and considered passed if compliance is achieved in all the parameters of 12 point check list in Clause 4.1 in Appendix 6.

Note:- For components level tests for Fire Protection System (FPS), please refer clause no. 4.0 of Appendix 7.

10. Page 15/35, Annex VI

Add following Annex VIA after existing Annex VI

“ANNEX VIA
(See Part III, clause 2.1.5.2)

**REQUIREMENTS FOR FIRE ALARM SYSTEM (FAS)
INSTALLED IN A SPECIFIC OCCUPANT COMPARTMENT**

1.0 Specifications

- 1.1 A specific occupant compartment means compartments which do not differ in the following essential aspects:
 - (a) No of Seats in compartment(s) for occupants including drivers’ cabin;
 - (b) Maximum gross volume;

(c) General layout of components in the compartment (i.e. position of fire hazards determined).

(d) Marking of exit routes, combustion heater and engine on the layout

1.2 The fire alarm system (FAS) conforming to this standard shall comply with the requirements of class A smoke and fire test.

2.0. Requirements

2.1 The class A smoke and fire test shall be conducted in accordance with Appendix 6 to test the response time of FAS.

3.0. FAS Installation

3.1 The detectors shall be mounted in the occupant compartment in such a manner that there will be line of sight to at least one detector from every class A fire source present in the occupant compartment, when the bus is empty, to ensure optimal coverage of threats of fire liable to break out in the occupant compartment.

3.2 The installation of the smoke detectors in occupant compartment without partition, shall be in such a way that each zone of 3.0 ± 0.5 meters of the bus length is covered by at least two detectors placed on the ceiling farthest from each other while maintaining a distance of about 0.8 ± 0.2 meter from zone boundary / sides of the bus. This is to provide the maximum coverage as well as to avoid false alarm from a smoke entering from windows.

The numbers of detectors in each zone may be higher or lower for special sensors such as multi-sensor type, aspirating type to meet the criteria mentioned in paragraph 3.7 below.

3.3 The installation of the smoke detectors in occupant compartment with partitions, shall be in such a way that each partition is covered by at least two smoke detectors placed on the ceiling farthest from each other while maintaining distance of 0.5 meter or more from sides of the bus/partition. The aim is to provide the maximum coverage within the partition.

3.4 The audio-visual alarm unit and control panel, having ingress level protection of IP54 or higher, will be positioned in the vicinity of the driver's dashboard in occupant compartment. Additional audio-visual alarm unit may be installed at the rear of occupant compartment, if required.

3.5 In addition, provision for manual means of activation of audio-visual alarm may be incorporated in the control panel as an option.

3.6 The fire shall be detected and warning signal shall be activated within 30 seconds after ignition of test fire #8. The test to be repeated at each of zone boundary, to cover atleast two of the following fire locations farthest from the passenger exit.

- a. near driver's seat,
- b. in the middle of the passenger compartment
- c. rear of the passenger compartment.

- 3.7 The test is considered passed if success was achieved at the first attempt or at two of three attempts in each case when first of these attempts fails.”

11. Page 16/35, Annex VII

Add following Annex VIIA after existing Annex VII

“ANNEX VII A
(See Part IV, clause 2.6.2)

**REQUIREMENTS FOR FIRE PROTECTION SYSTEM (FPS)
INSTALLED IN A SPECIFIC OCCUPANT COMPARTMENT**

1.0. Specifications

- 1.1. A specific occupant compartment means compartments which do not differ in the following essential aspects:
- (a) Position of passenger exit (s) in the vehicle;
 - (b) Maximum gross volume;
 - (c) General layout of components (seats, partitions, luggage rack etc.) in the compartment (i.e. position of fire hazards determined) and placement of engine outside the compartment.
- 1.2 The fire protection system (FPS) conforming to this standard shall comply with the requirements of Part IV in order to achieve intended purpose of occupant protection from fire to provide time for evacuation with and without windows open.

2.0. Requirements

- 2.1 The FPS system key components are type tested and meet all the requirement of safety, design and operation from this standard to achieve the service requirements.
- 2.2 The FPS installed for an appropriate occupant compartment to be activated manually through an electrical switch positioned in the vicinity of the driver’s dashboard, to actuate the connected solenoid valve or pumping device to perform one or more functional tests in Appendix 6.

3.0. FPS Installation

The functional and evaluation test conditions in Appendix 6 may be adapted for the specific occupant compartment. The adaptation shall be based on the provisions given in Part IV, Clause nos. 4 and 5 determining the fire hazards within the compartment and the volume based scaling of the fire protection system. Any adaptation shall provide an equivalent level of safety. The principles for the adaptation, if any, shall be verified by the Test Agency responsible for the tests. The principle of adaption shall be documented and added to the test report.

- 4.0 Test and Evaluation of FPS installed in Occupant Compartment.**
- 4.1 The FPS shall be capable to be remotely activated from control panel positioned in the vicinity of the driver’s dashboard, through electrically operated solenoid valve either on confirmation of fire or immediately after receiving Audio-visual Signal from Fire Alarm System
- 4.2 Fire protection System (FPS) conforming to this standard shall comply with the requirements of Part IV of this standard within occupant compartment.
- 4.3 The test apparatus for functional test, evaluation of design and documentation are described in Clause 4.0 of Appendix 6.
- 4.4 A declaration by the manufacturer, that an additional test has been conducted with the water vessel as well as the dry air (propellant gas) vessel or suitable technology cooled to the minimum operating temperature (“5” degrees celsius) and the discharge point flow characteristics (Clause 4.3 Appendix 6) were found to be conforming to the Part IV of the standard, to be submitted.
- 4.5 The FPS is expected to achieve intended purpose and considered passed if compliance is achieved in all the parameters of 12 point check list in Clause 4.1 in Appendix 6.”

12. Page 18/35, Annex VIII

Substitute following Annex VIII for existing Annex VIII

“ ANNEX VIII

(Clause 3.0 of Parts I & II and Clause 3.1 of Parts III & IV)

GUIDELINES FOR DECIDING WHETHER TESTING IS NEEDED

1. In general, when changes in technical specifications of vehicle do not affect the FDAS / FDSS/ FAS /FPS performance adversely, and is still within the stipulated limits, the type approval certificate can be extended. The changes in parameters that affect the FDAS / FDSS and FAS / FPS performance are listed in clause No. 2 and 3 respectively.
2. In the case of following changes, with respect to the vehicles tested, in the details submitted as per Annexures I and II, tests are necessary for establishing compliance:

1.	Change in volume of engine compartment	To be tested if volume of engine compartment is increased which increases the number of nozzles derived from clause no. 4.5.3
2.	Type of fire suppression agents	To be tested in case of any change
3.	Change in capacity of fire suppression agent	To be tested in case of decrease in capacity
4.	Dimensions of pipes & fittings of FDSS & FDAS	To be tested in case of any change
5.	Pressurized cartridge system	To be tested in case of decrease in pressure of the system

3. In the case of following changes, with respect to the vehicles tested, in the details submitted as per Annexures IA & IIA tests are necessary for establishing compliance:

1.	Change in volume category of occupant compartment	To be tested for compliance as the change will lead to increase in the number of nozzles as per from clause no. 4 & 5 Part IV
2.	Exceeding maximum number of seats corresponding to specific volume category of occupant compartment	To be tested with volume corresponding to applicable seats which increases the number of nozzles derived from clause no. 4 & 5, Part IV
3.	Change in water capacity of fire suppression system	Compliance with Part IV to be tested
4.	Dimensions of pipes & fittings of FPS	Compliance with Part IV to be tested
5.	Change in Pressurized dry air cylinder	Compliance with Part IV to be tested in case of decrease in stipulated pressure and/or change in capacity
6.	Type, characteristics and location of the nozzles	Compliance with Part IV to be tested
7.	Type of solenoid valve, pressure regulating valve, safety / relief valve	Compliance with Part IV to be tested
8.	Type of detector in FAS or number of detection zones	To be verified for compliance with Part III

4. Changes other than the above are generally considered as not affecting compliance. However it does not limit test agencies and vehicle manufacturer to investigate possibility of any other criteria, for which tests may be conducted for extension as per mutual agreement between test agencies & vehicle manufacturer.”

13. Page 33/35, Appendix 5

Add following Appendices 6 and 7 after existing Appendix 5

“APPENDIX 6

TEST APPARATUS, TEST FIRES AND GENERAL TEST SPECIFICATIONS FOR OCCUPANT COMPARTMENT

1.0 This test protocol intends to provide basis for tests for FAS under Part III and FPS under Part IV, for buses having occupant volumes upto 80m³ and having corresponding seating capacity upto 80.

2.0 Tests and Test Apparatus

2.1 For functional tests and evaluation check list of FAS and FPS, the test apparatus of specific volume bus body, complied to AIS-052 (Rev.1), for which approval is being sought, to be used.

2.2 The tests for FAS and FPS include functional tests, design evaluation check list as well as mandatory documentation as per clause 4 and 5 of Part IV

- a. Fire Alarm System – functional test
- b. Fire Protection System – functional test (Water Discharge Rate Test) and design parameters verification using check list.

2.3 For optional simulation tests the test apparatus to be based of bus body CAD drawing, for which approval is being sought, along with details of all the combustible materials in occupant compartment and the water mist injection system of requisite size and key design features using test protocol fire size and temperature measurement using thermocouple (clause 6 below) to be used for performance evaluation.

3.0 Test of Fire Alarm System – The functional test for FAS involve a limited design fire for evaluating the performance of detectors and audio-visual alarms system.

Time	Action
00:00	Start igniting design fire #8
00:30	Alarm should have activated automatically. *
* Time in seconds after which alarm activates along with location of fire shall be recorded in the test report.	

4.0 Test and Evaluation of Fire Protection System

4.1 Evaluation Tests for FPS include a checklist for fire protection system to be used for review and record pertaining to installation of FPS, a 12 point check list to be used for test and approval as per this standard. The column “Criteria” indicates either the national /international standard being referred in the design or system requirements elaborated in Clause 4 and 5 of Part IV and test in this Appendix.

S. No.	Test Parameter	Criteria
1.	Propellant Gas Quality	Dry Air standard
2.	Propellant Gas Cylinder Capacity and Operational Pressure	Sufficient to provide 3 mins system operation
3.	Propellant Gas Cylinder Test Pressure	Relevant safety code or 1.5 times of operation pressure whichever is higher
3.	Pressure Reducing Valve	Required reduction and lockable adjustment knob
4.	Propellant Gas Cylinder Safety	Relevant IS standard
5.	Solenoid Valve	Remote Activation for 3 minutes operation
6.	Water Cylinder Capacity and Operational Pressure	Sufficient to provide 3 mins system operation
7.	Water Cylinder Test Pressure	Relevant safety code or 1.5 times of operation pressure whichever is higher
8.	Nozzle Characterization – three parameters in Clause 4.5.6 Part IV for each nozzle.	Certification from Test agencies /BIS/NABL recognized lab
9.	Total Nozzles and layout	As per clause 5.3 Part IV
10.	Pipe Network pressure optimization	As per clause 4 & 5 Part IV
11.	Pipe & Fittings material & type	Relevant Standard and Record as per Clause 4.2 Appendix 6
12.	FPS Functional Test - flow characteristics of each nozzle for 3 minutes operation	Record as per Clause 4.3 Appendix 6

4.2 Hydrostatic testing of pipe network requires atomizer locations to be plugged before the test takes place. Each section shall be pressurized upto 1.5 times the working pressure or as per Indian standard IS 15519 criteria of acceptance whichever is stringent. During the test no pressures loss to be observed and record to be made. In the event of leakage, the pressure shall be removed from the system, appropriate corrective action to be taken and the test procedure to be repeated.

4.3 Functional Test of FPS are intended for checking flow characteristics of installed Fire Protection System. Each discharge point is loosely wrapped (to allow air to escape) with 10 liters capacity plastic bag to collect the water during 3 minutes of system operation.

Time	Action
00:00	Start FPS
00:10	FPS activation confirmation
03:10	Manual switch off of FPS
* Time in seconds for system operation, normal operational pressure and water volume at each discharge point, in liters, shall be recorded in the test report.	

5.0 Optional Simulated Fire Test for FPS

- 5.1 Simulated conditions for four fire scenarios are recommended to be used for design validation, improvements and performance evaluation of FPS using Fire Dynamics Simulator software (i.e. PYROSIM). The pre-burn time for heat and smoke from external fire is given as 45 seconds. These optional tests are intended to provide a standard framework for evaluation of FPS irrespective of the size and type of buses and where full scale fire tests are not feasible.
- Occupant Compartment Fire using simulated fire test #9
 - Engine Fire using simulated fire test #10
 - Fuel Tank Fire using simulated fire test #11
 - Braking System/Tyre Fire using simulated fire test #12

- 5.2 The Occupant Compartment Fire using test #9 is intended for generation of response data for Fire Protection System in case of simulated design fire in occupant compartment. Following is the expected outcome:

Time	Action
00:00	Simulate start of design fire #9 at designated location
00:45	Activation of water mist system
01:45	FPS should have suppressed the Fire

- 5.3 The Engine Fire using simulated test #10 is intended for checking thermal management of Fire Protection System when subjected to external engine fire using simulation with following expected outcome:

Time	Action
00:00	Simulate ignition /start of engine fire #10
00:45	Activation of suppression system
01:45	FPS should have managed the temperature inside the occupant compartment and cooled the smoke layer
03:45	Fire Protection System to control the temperature upto 50 ⁰ C.

- 5.4 The Fuel Tank Fire using simulated test #11, intended for checking thermal management of Fire Protection System subjected to fuel tank pool fire, is expected to have following outcome:

Time	Action
00:00	Simulate ignition start of external fuel tank fire#11
00:45	Activation of suppression system
01:45	FPS should have managed the temperature inside the occupant compartment and cooled the smoke layer
03:45	Fire Protection System to control the temperature below 50 ⁰ C.

- 5.5 The Braking System / Tyre Fire using simulated test #12 intended for checking thermal management of Fire Protection System subjected to braking system /tyre fire, is expected to have following outcome:

Time	Action
00:00	Simulate ignition start of external fire
00:45	Activation of suppression system
01:45	FPS should have managed the temperature inside the occupant compartment and cooled the smoke layer
03:45	Fire Protection System to control the temperature below 50 ⁰ C.

- 5.6 In the case of simulated tests under clause 5.2 to 5.5 above, in non-air-conditioned bus, each simulation study to be performed for following two conditions
- With all windows open
 - With all windows open and the bus moving at 10km/hour at the start of the test fire and the bus comes to complete halt in next 10 seconds.

6.0 Test fires

- 6.1 For external fire where test apparatus made of real scale occupant compartment cannot be used, the CAD design of test apparatus passenger compartment will be used for fire simulation studies using specialized software.
- 6.2 The test fires in table below are to be used in the different test scenarios described in the standard. For test and simulated fires Diesel oil (commercial fuel oil or light diesel oil), heptane (C₇H₁₆) and engine oil 15W-40 with a flash point of 230 °C and viscosity at 40 °C of 107 mm²/s shall be used as test fuels. The peak HRR is based on 45 sec after ignition

Test Fire No.	Description	Fuel	~ peak HRR KW	Purpose
#8	Smoke & Class A Fire, on a middle Seat between the nozzles	PU foam+ fibreboard+ cotton fabric wrap	40	FAS Test and Simulated Fire Suppression
#9	Multiple Class A Fire in each zone 300×300x70 mm	Diesel oil and n-heptane	40xNo of Zones	Simulated Fire Suppression in each zone
#10	Engine Fire, Large Spray (External)	Diesel oil (#6, Appendix 1)	520	Simulated Thermal Management
#11	Fuel Tank Fire, Large Pool (Indirect)	Diesel oil	500	Simulated Thermal Management
#12	Bus Braking/tyre fire, Large Pool (Indirect)	Diesel oil	520	Simulated Thermal Management

- 6.3 Square type of pool fire trays as per the description given for the respective fire tests.

Dimensions	Rim height	Nominal thickness	Used for test fire
300 mm × 300 mm	70 mm	1.5 mm	#8, #9
500 mm × 500 mm	70 mm	1.5 mm	#11, #12

- 6.4 The Test fire #8 consist of a fibreboard with a dry density of 3.5 kg/m³. The dimensions of the fibreboard shall be 12 mm × 295 mm × 295 mm. The fibreboard shall consist of at least 90 per cent raw material from wood. The moisture content in the boards before they are soaked in diesel oil shall not exceed 7 per cent.
- 6.5 The fibreboard along with a PU foam of size 50 mm × 295 mm × 295 mm shall be completely wrapped with upholstery cotton cloth of not less than 1000 mm in length and 500mm in width. Two rolls of cotton to be each soaked in 20 ml diesel and 10 ml n-heptane to be placed on top for fire ignition using a torch. The amount of PU foam,

fibreboard, cotton cloth, water, diesel and heptane used in the tests should be in accordance with following table.

PU Dimensions (mm)	Diesel	n-Heptane	PU Foam weight	Test fire
300 × 300 × 50	40 ml	20 ml	~280gm	#8, #9

6.6 The set of one fibreboard, one PU foam wrapped with cotton upholstery shall be positioned flat inside the square fire trays in such a way that two small rolls of cotton fabric for fire ignition can be placed on top to meet the requirements of test #8. Similar arrangement needs to be made in each zone for test #9. Simulated Test fire #10 consists of diesel oil spray fires while Test fire #11 & #12 consist of large oil pool fire (by hot surface ignition).

7.0 Thermocouples in Simulation Studies

7.1 Four thermocouples (Tc) shall be mounted on the surface while another four towards the ceiling as per coordinates given. At least two (Tc8 & Tc9) over the engine area on the passenger floor, three (Tc10, Tc11, Tc12) to be placed equidistant from each other along the length on the ceiling. Here Tc10 & Tc12 will be placed close to ceiling while Tc11 to be placed 0.5 meter below the ceiling. Further one thermocouple each at main service door (Tc15) 1.6 meter from floor, at just above the fuel tank (Tc14) and at emergency exit (Tc13) to be placed along the floor. The coordinates of thermocouple locations from the front edge of Service door and their temperature in every 30 seconds from start of simulation to be studied for evaluation of FPS.

Thermocouple	Coordinates [x; y; z]	Thermocouple	Coordinates [x; y; z]
Tc8	[x1; y1; 0]	Tc12	[x5; y3; z3]
Tc9	[x2; y2; 0]	Tc13	[x6; y4; 0]
Tc10	[x3; y3; z3]	Tc14	[x7; y5; 0]
Tc11	[x4; y3; (z3-0.5)]	Tc15	[x8; y6; 0]

7.2 The location of the thermocouples is illustrated in figures below.

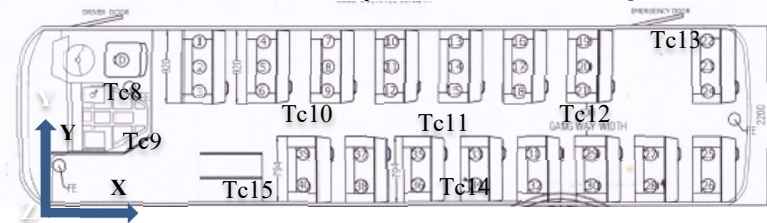

8.0 Tolerances

8.1 A tolerance of ±5 per cent of the stipulated values shall apply (for time values: ±5 seconds). These tolerances are applicable to test set up parameters only. These tolerances are not applicable to performance duration (e.g. FAS / FPS performance time parameters).

APPENDIX 7

GENERAL GUIDELINES

1.0 These guidelines are being included to facilitate implementation of a fire safety system, which is reliable during its life cycle. For desired results from proposed FAS and FPS, it is essential to include reliable components at design stage, adherence to good engineering practices during installation and regular preventive and breakdown maintenance of the

system during operation. In order to keep the FAS and FPS functional at all times, it is essential that relevant communication is shared with concerned agencies dealing with the system in its different stages. Following aspects are considered essential for being covered.

- a. Components Selection and testing for FAS and FPS
- b. Documentation on
 - i. Maintenance Requirements
 - ii. Reactivation of FPS after release of water mist
 - iii. Training Requirements

2.0 Components Selection and testing for FAS and FPS

- 2.1 It is recommended that the selection of components, even at the initial stage of implementation, should be based on the overall objective of achieving high system reliability. This goal will be achieved if components of higher reliability selected in the beginning. Initially it is not expected to have reliability data of all the components, however as the implementation of this standard progresses, the reliability is expected to improve with time.
- 2.2 The recommended type testings' of components are shock, vibration, cyclic and drop tests. The component level tests guideline are recommended to be as per clause 4.2 of this appendix or as per AIS-018. However complying to the relevant aspects of tests and approval requirements of water mist systems as per IS 15519 shall be recorded.
- 2.3 Any of the components, where choice between national/international standard exist, is recommended to adhere the more stringent standard. Identifying the relevant standards early on will ensure development of a quality fire alarm system and fire protection system.
- 2.4 While selecting the components, routing of cables, wires, pipes etc. a careful consideration is expected to be given to system safety. Any component which might get impacted due to tempering by passengers also needs to be suitably protected and/or laid accordingly. For example, the water mist nozzles may include a protection cap to protect the nozzles from dust and other blockages over the years. The nozzle protection cap, if provided, shall be released or ruptured as soon as the pressure is build-up in water distribution header. Similarly, wherever smoke detectors are being used in FAS, their installation is to be undertaken in such a way that interference from dust is minimized. This presents a challenge for non-air-conditioned bus and therefore a specially designed housing, dust protector along with dust compensation may provide better results and lower day to day maintenance.

3.0 Documentation

Besides the drawings, installation manual **and** necessary documentation as part of the standard, some add-on documentation covering different aspects of maintenance and training are required to supplement a good engineering design.

3.1 Maintenance Requirements:

There will be a day to day up-keep requirements to keep the system in operational mode. For example, this may include testing /cleaning of smoke sensors, nozzles, checking of water in the water cylinder and pressure in the gas cylinder. Then there would be preventive maintenance to ensure the continued functionality of FAS and FPS which may include the charging of auxiliary power batteries and step by step method to make the system functional if the system is not working as intended. The guidelines here are not exhaustive but only for illustration purposes.

3.2 Reactivation of FPS after release of water mist

The SOP provided by the manufacturer is expected to elaborate on reactivation of FAS and FPS, including leak test after a fire incident or accidental actuation.

3.3 Training Requirements –

The FAS and FPS in occupant compartment compliment other fire safety measures such as already installed FDAS and FDSS in engine compartment and the mandatory portable fire extinguisher kept on-board the buses. Therefore, the choice of fire safety measure primarily rests with the driver or the attendant. A bus fire incident (internal or external to the occupants) in the initial stage can be effectively managed using the portable extinguishers. Similarly, in case of engine fire, the incident can be effectively managed using FDSS if detected in time. Making the drivers and attendants to understand their role in handling different fire scenarios will be the key element to save precious lives of bus occupants. The manufacturer is expected to clearly spell out the roles of driver and attendant during operation and maintenance. This followed by regular training and mock drills to the concerned personnel will alone enable best use of FAS and FPS.

4.0. Guidelines for Component Level Tests (common requirements for FAS & FPS)

4.1 Functional Test:

This test is applicable on all electronics devices (e.g. detectors, solenoid valves etc.) of FAS & FPS system. The component shall be connected to rated voltage. The component shall be coupled with the suitable rig which can simulate the required function of device. The maximum current consumption (A) shall be recorded. The maximum current shall not exceed the values specified by the manufacturer.

4.2 Endurance Test under Vibration Test:

Each electronic component (e.g. detectors, solenoid valves etc.) and the water pressurization system (WPS) (filled with water) shall be mounted in actual vehicle's orientation with suitable fixture and subjected to following Vibration Tests:-

A. Sine Sweep Vibration Test:

Frequency Range1 : 10 to 30 Hz
Amplitude : ± 2 mm
Frequency Range2 : 30 to 1000 Hz
Acceleration : 2.5g
Sweep Rate : 1 Octave/min.
Test Duration : 1 hr. in each axis (X, Y & Z)

B. Mechanical Shock Test:

Acceleration : 50g
Duration : 11 ms
No. of Shocks : 60 Nos. [20 shocks in each axis {10 positive and 10 negative;}]

After performing above vibration tests, the functional check shall be done as per clause no. 3.1. For WPS, there shall not be any breakage or crack of mountings and other component

4.3 Endurance Test at High Temperature:

Each electronic component (e.g. detectors, solenoid valves etc.) shall be mounted in actual vehicle's orientation and subjected to endurance test at high temperature in climatic chamber at temperature of $65 \pm 5^\circ\text{C}$ for 12,500 cycles.

The mechanical components shall be subjected to high temperature at $100 \pm 5^{\circ}\text{C}$ for 240 h.

After performing above tests, the functional check shall be done as per clause no. 3.1. For mechanical components, there shall not any breakage, crack, discoloration etc.

4.4 Endurance Test at Low Temperature:

Each electronic component (e.g. detectors, solenoid valves etc.) shall be mounted in actual vehicle's orientation and subjected to endurance test at low temperature in climatic chamber at temperature of $-20 \pm 5^{\circ}\text{C}$ for 12,500 cycles.

The mechanical components shall be subjected to low temperature at $-20 \pm 5^{\circ}\text{C}$ for 240 h. The size of test component shall be mutually agreed between test agency and the manufacturer.

After performing above test, the functional check shall be done as per clause no. 3.1. For mechanical components, there shall not any breakage, crack, discoloration etc.

4.5 Endurance Test – Salt Spray Test:

Each electronic component (e.g. detectors, solenoid valves etc.) shall be mounted in actual vehicle's orientation and subjected to endurance test while keeping the component in salt spray chamber with 5% concentration of sodium chloride and internal temperature of $35^{\circ}\text{C} \pm 2^{\circ}\text{C}$ for 12500 cycles.

The mechanical components (e.g. tubings, connectors, water tank, nozzles etc.) shall be subjected to salt spray test as per above said specifications for 240 h. The size of test component shall be mutually agreed between test agency and the manufacturer.

After performing above test, the functional check shall be done as per clause no. 3.1. For mechanical components, there shall not any corrosion or any other abnormal sign.

4.6 Endurance Test at High Humidity:

Each electronic component (e.g. detectors, solenoid valves etc.) shall be mounted in actual vehicle's orientation and subjected to high humidity test while keeping the component in a humidity chamber at $95\% \pm 3\% \text{ Rh}$ for 12500 cycles.

After performing above test, the functional check shall be done as per clause no. 3.1.

4.7 Drop Test:

Each electronic component (e.g. detectors, solenoid valves etc.) shall be subjected to drop and topple test as per Clause 4.10 of IS: 10250-1982 with a drop height of 200 mm. The number of drops shall be 6 Nos.

After performing above test, the functional check shall be done as per clause no. 3.1. Also there shall not be any breakage or crack of component.”

4.8 Hydrostatic testing

A hydrostatic test as per clause 5.4.3 of Part IV is a pressure test in which the piping network of FPS is pressurized to evaluate its integrity. This test evaluates the structural

integrity of pipeline or other pressure containing sub-systems. During the test, the pipe is filled with water and the water pressure is gradually increased, held for a certain duration to check the pressure drop, leakages etc. and then released. The test is mandatory to be performed when the FPS is put into service and after a certain length of operation to evaluate the integrity of the system. It is important to remove all water used for hydrostatic test and dry the pipeline before operation, otherwise the segment of the system which generally remain dry may accumulate water and become susceptible to internal corrosion.

- 4.9 Reference is made to para 4.5.6 of Part IV of this standard to elaborate on nozzle characteristics. The D32 is used here as one of the measures of central tendency in droplet sizes, based on ratio of volume to surface area, for heat transfer applications. And Dv90, an indication about polydispersity of droplet sizes in the water jet, represent maximum droplet size of 90% volume fraction.
- 4.10 For protecting the occupant compartment at atmospheric temperatures below 50C, the water as suppression agent may be used with additives (to reduce the freezing point) at pre-determined specific concentration that has been evaluated as safe for human exposure by an appropriate authority.

PRINTED BY
THE AUTOMOTIVE RESEARCH ASSOCIATION OF INDIA
P.B. NO. 832, PUNE 411 004
ON BEHALF OF
AUTOMOTIVE INDUSTRY STANDARDS COMMITTEE
UNDER
CENTRAL MOTOR VEHICLE RULES – TECHNICAL STANDING COMMITTEE
SET-UP BY
MINISTRY OF ROAD TRANSPORT & HIGHWAYS
(DEPARTMENT OF ROAD TRANSPORT & HIGHWAYS)
GOVERNMENT OF INDIA
27th January 2022

AUTOMOTIVE INDUSTRY STANDARD

**Fire Detection and Alarm System
(FDAS) & Fire Detection and
Suppression Systems (FDSS) for Buses
- Requirements**

PRINTED BY
THE AUTOMOTIVE RESEARCH ASSOCIATION OF INDIA
P.B. NO. 832, PUNE 411 004

ON BEHALF OF
AUTOMOTIVE INDUSTRY STANDARDS COMMITTEE

UNDER
CENTRAL MOTOR VEHICLE RULES – TECHNICAL STANDING COMMITTEE

SET-UP BY
MINISTRY OF ROAD TRANSPORT and HIGHWAYS
(DEPARTMENT OF ROAD TRANSPORT and HIGHWAYS)
GOVERNMENT OF INDIA

October 2016

Status chart of the Standard to be used by the Purchaser for updating the record

Sr.	Corrigenda	Amendment	Revision	Date	Remark	Misc.

General Remarks:

INTRODUCTION

The Government of India felt the need for a permanent agency to expedite the publication of standards and development of test facilities in parallel when the work on the preparation of the standards is going on, as the development of improved safety critical parts can be undertaken only after the publication of the standard and commissioning of test facilities. To this end, the erstwhile Ministry of Surface Transport (MoST) has constituted a permanent Automotive Industry Standards Committee (AISC) vide order No. RT-11028/11/97-MVL dated September 15, 1997. The standards prepared by AISC will be approved by the permanent CMVR Technical Standing Committee (CTSC). After approval, the Automotive Research Association of India, (ARAI), Pune, being the secretariat of the AIS Committee, will publish this standard.

Considering that:

- There is a sense of urgency as evidenced by the formulation of Fire Detection & Suppression System requirements and specified in Urban Bus Specification II for implementing the required fire safety technologies;
- There are no mandatory regulations exist internationally for Fire Detection and/or Suppression Systems;
- The document (ECE/TRANS/WP29/2015/88) from which reference have been drawn for preparing the standard has been voted for implementation in the WP 29 session – 167th session dated November 2015. Further discussions on this standard are ongoing in UNECE which will be monitored & suitably drawn into this standard at an appropriate time.
- a significant majority of the bus fire accidents on Indian roads originate from the engine bay of the vehicle.

This Committee has decided to create rules in progression adapted from this document as follows:

Part I: Regulations for Detection & Alarm Systems for fires originating from engine compartment of buses

Part II: Regulations for Detection & Suppression of fires originating from engine compartment of buses

Till such time as relevant portions of the standard are brought into force for the vehicles scoped therein, institutional and private procurers of such buses would have the option to specify FDAS or FDSS complying with this standard as part of their procurement requirements.

It is to be recorded the UNECE WP.29 has voted and accepted the UNECE regulations on this subject. However the final version of UNECE regulation reflecting the decision is yet to be made available. Such changes in the UNECE document will be monitored and suitably implemented in this standard.

Composition of the panel and Automotive Industry Standards Committee (AISC) responsible for preparation of this standard are given in Annex IX and X.

Clause No.	Contents	Page No.
1.0	Scope	1/35
2.0	References	1/35
	Part I - Requirements for Buses with regard to Fire Detection & Alarm System (FDAS)	
1.0	Definitions	2/35
2.0	Application For CMVR Approval	2/35
3.0	Modification and Extension of Approval of A Vehicle or Bodywork Type	3/35
4.0	General Requirements	3/35
	Part II - Approval of Buses with regard to Fire Detection & Suppression System (FDSS)	
1.0	Definitions	5/35
2.0	Application For CMVR Approval	5/35
3.0	Modification and Extension of Approval of A Vehicle or Bodywork Type	6/35
4.0	General Requirements	6/35
Annex I	Information to be Submitted for Type Approval of Buses with Regard to Fire Detection and Alarm System	8/35
Annex II	Information to be Submitted for Type Approval of Buses with Regard to Fire Detection and Suppression System	9/35
Annex III	Information to be Submitted for Component Level Approval of Fire Detection & Alarm System and Fire Detection & Suppression System	10/35
Annex IV	Requirements for Fire Detection & Alarm System (FDAS) Approved as a Component	11/35
Annex V	Requirements for Fire Detection & Suppression System (FDSS) Approved as a Component	12/35
Annex VI	Requirements for Fire Detection & Alarm System (FDAS) Installed in a Specific Engine Compartment	15/35
Annex VII	Requirements for Fire Detection & Suppression System (FDSS) Installed in a Specific Engine Compartment	16/35

Annex VIII	Guidelines for Deciding Whether Testing is Needed	17/35
Appendix 1	Test apparatus, test fires and general test specifications	19/35
Appendix 2	High fire load scenario	28/35
Appendix 3	Low fire load scenario	30/35
Appendix 4	High fire load scenario with fan	32/35
Appendix 5	Re-ignition scenario	33/35
Annex IX	Composition of AISC Panel	34/35
Annex X	Committee Composition - Automotive Industry Standards Committee	35/35

**Fire Detection and Alarm System (FDAS) &
Fire Detection and Suppression Systems (FDSS) for Buses
– Requirements**

1.0 SCOPE

- 1.1 This standard specifies the guidelines for detection and suppression systems for fires that may originate from engine compartment of buses.
- 1.2 This standard applies to
 - 1.2.1 Part I – Fire Detection and Alarm Systems (FDAS)
Approval of Fire Detection and Alarm Systems (FDAS) which are fitted to Buses.
 - 1.2.2 Part II – Fire Detection and Suppression Systems (FDSS)
Approval of Fire Detection and Suppression Systems (FDSS) which are fitted to Buses.
- 1.3 Buses fitted with FDAS & FDSS shall comply with the recommendatory requirements of this standard, if required.
- 1.4 The requirements of this standard shall not be applicable for Electric Powertrain Vehicles (EVs).

2.0 REFERENCES

- 2.1 AIS-052 (Rev. 1) - Code of Practice for Bus Body Design and Approval.
- 2.2 UN R 107-06 (Rev.6/Corr.1, 8th December 2014) – Uniform provisions concerning the approval of category: M2 or M3 vehicles with regard to their general construction.
- 2.3 IS 2175 Specification for Heat Sensitive Fire Detectors for use in Automatic Fire Alarm System.
- 2.4 I.S. 6278, Part 3 (2013) (Israel Standard) - Automatic Fire Extinguishing Systems in Bus Engine Compartments: Installation and Maintenance.
- 2.5 FM 3210:2007 Heat Detectors for Automatic Fire Alarm Signaling.
- 2.6 UL 521 Heat Detectors for Fire Protective Signaling Systems.

PART I
Requirements for Buses with regard to
Fire Detection & Alarm System (FDAS)

1.0. DEFINITIONS

For the purpose of Part I of this standard,

- 1.1. Automatic Fire Detection and Alarm System - A system comprising of components and sub-systems required for automatically detecting a fire and initiating an automatic alarm.
- 1.2. 'Engine compartment' means the compartment in which the engine is installed and / or in which a combustion heater may be installed.
- 1.3. Fault Signal - A distinctive audible and visual signal indicating occurrence of a fault within the FDAS / FDSS system (for example, break in electric circuit, short circuit or fault in power supply, mechanical damage in detector or elsewhere in system).
- 1.4. Alarm Signal - A signal is an audio and visual signal initiated by a fire alarm-initiating device, such as a manual fire alarm box, automatic fire detector, water flow switch, or other device in which activation is indicative of the presence of a fire or fire signature.
- 1.5. Fire detection system type for the purpose of type approval as a component means a category of systems which does not essentially differ in the following aspects:
 - a) Detection system;
 - b) detector;
 - c) triggering device at end of detector;
 - d) ECU.
- 1.6. Heat Detector - A heat detector is a sensor that senses either abnormally high temperature or rate of temperature rise, or both.

2.0. APPLICATION FOR CMVR APPROVAL

- 2.1. Application for CMVR type approval for a vehicle type in respect of the fire detection and alarm system (FDAS).
 - 2.1.1. The application for approval of:
 - (a) A vehicle type or;
 - (b) A separate technical unit type or;
 - (c) A vehicle type fitted with bodywork type already approved as a separate technical unit or;
 - (d) A component type with regard to its constructional features shall be submitted by the manufacturer or by his duly accredited representative.
 - 2.1.2. It shall be accompanied by the documents containing the information specified in Annex I & III as applicable.
 - 2.1.2.1. Detailed description of the vehicle type with regard to the arrangement

and design of the control or of the unit on which the fire detection and alarm system acts.

- 2.1.3 A vehicle representative of the type to be approved shall be submitted to the test agency.
- 2.1.4 A vehicle not comprising all the components proper to the type may be accepted provided that it can be shown by the applicant to the satisfaction of the test agency that the absence of the components omitted has no effect on the results of the verifications, so far as the requirements of this standard are concerned.
- 2.1.5 In case of application for approval of a type of vehicle, the manufacturer shall also provide the following documents, :
 - 2.1.5.1. Information regarding the installed fire detection & alarm system (FDAS):
 - 2.1.5.1.1 In case of a fire detection & alarm system (FDAS) approved as a component, a copy of the analysis on regarding the installation of the FDAS (see Annex IV) or
 - 2.1.5.1.2 In case of a fire detection & alarm system (FDAS) installed in a specific engine compartment, an analysis on regarding the installation of the FDAS (see Annex VI)

3.0 MODIFICATION AND EXTENSION OF APPROVAL OF A VEHICLE OR BODYWORK TYPE

- 3.1 Every modification of the vehicle, bodywork type or fire detection & alarm system shall be notified to the test agency which approved the type. That test agency may then determine that: (see Annex VIII)

Either that the modifications made are unlikely to have an appreciable adverse effect and that, in any case, the vehicle, bodywork or fire detection system still complies with the requirements; Or require a further test of compliance from the manufacturer.

4.0. GENERAL REQUIREMENTS

- 4.1 Vehicles shall be equipped with fire detection & alarm system detecting fires in the engine compartment based on sensors that senses either abnormally high temperature or rate of temperature rise, or both.
- 4.2 Upon detection in engine compartment, the system referred in clause no 4.1, shall provide the driver with both an acoustic and a visual signal, and activate the hazard warning signal. The placement of the visual alarm shall be such that it is visible unobstructed while viewed from the driver seat.
- 4.3 The detection & alarm system shall be operational irrespective of whether engine has been started and the vehicle's attitude.
- 4.4 The installation of the fire detection & alarm system shall comply with the following requirements;
 - 4.4.1. The fire detection & alarm system shall be installed according to the system manufacturer's installation manual.

- 4.4.2 An analysis shall be conducted prior to the installation in order to determine the location of fire detectors and alarm system. Potential fire hazards within the engine compartment shall be identified such that the fire detectors shall be positioned to cover the fire hazard. The system shall also be ensured to work properly regardless of the vehicle's altitude, road conditions etc.,
- 4.4.3 Fire hazards to be taken into account in the analysis shall at least consist of the following: Components whose surface may reach temperatures above the auto-ignition temperature for fluids, gases or substances that are present within the compartment and electrical components and cables with a current or voltage high enough for an ignition to occur as well as hoses and containers with flammable liquid or gas (in particular if those are pressurized). The analysis shall be fully documented.

PART II**Approval of Buses with regard to
Fire Detection & Suppression System (FDSS)****1.0. DEFINITIONS**

For the purpose of Part II of this standard,

- 1.1 Fire Detection and Suppression System is a FDAS (Fire Detection & Alarm System) with additional facility to automatically trigger fire extinguishing system capable of extinguishing fire in engine compartment.
- 1.2 "Approval of a vehicle, or a separate technical unit or a component" means the approval of a vehicle type, or of bodywork or of a component type with regard to the constructional features specified in this Standard;"
- 1.3 "Fire suppression system type" for the purpose of type approval as a component means a category of systems which does not essentially differ in the following aspects:
 - (a) fire suppression system manufacturer;
 - (b) extinguishing agent;
 - (c) type of discharge point(s) used (e.g. type of nozzle, extinguishing agent generator or extinguishing agent discharge tube);
 - (d) type of propellant gas, if applicable."

2.0. APPLICATION FOR CMVR APPROVAL

- 2.1 The application for approval of:
 - (a) A vehicle type or;
 - (b) A separate technical unit type or;
 - (c) A vehicle type fitted with bodywork type already approved as a separate technical unit or;
 - (d) A component type with regard to its constructional features shall be submitted by the manufacturer or by his duly accredited representative.
- 2.2 It shall be accompanied by the documents containing the information specified in Annex II and III.
- 2.3 Detailed description of the vehicle type with regard to the arrangement and design of the control or of the unit on which the fire detection & suppression system acts.
- 2.4 A vehicle or fire detection & suppression system representative of the type to be approved shall be submitted to the test agency.
- 2.5 A vehicle not comprising all the components proper to the type may be accepted provided that it can be shown by the applicant to the satisfaction of the test agency that the absence of the components omitted has no effect on the results of the verifications, so far as the requirements of this standard are concerned.
- 2.6 In case of application for approval of a type of vehicle, the manufacturer shall also provide the following documents, if applicable:
 - 2.6.1. Information regarding the installed fire detection & suppression system:

- 2.6.1.1 In case of a fire detection & suppression system (FDSS) approved as a component, a copy of the analysis on regarding the installation of the FDSS (see Annex V) or
- 2.6.1.2 In case of a fire detection & suppression system (FDSS) installed in a specific engine compartment, an analysis on regarding the installation of the FDSS (see Annex VII)

3.0. MODIFICATION AND EXTENSION OF APPROVAL OF A VEHICLE OR BODYWORK TYPE

- 3.1 Every modification of the vehicle, bodywork type or fire detection & suppression system shall be notified to the test agency which approved the type. That test agency may then determine that: (see Annex VIII)

Either that the modifications made are unlikely to have an appreciable adverse effect and that, in any case, the vehicle, bodywork or fire suppression system still complies with the requirements; Or require a further test of compliance from the manufacturer.

4.0. GENERAL REQUIREMENTS

- 4.1 In the case of vehicles having an internal combustion engine or a combustion heater located either to the front or rear, the engine compartment shall be equipped with a fire alarm system providing the driver with both an acoustic and a visual signal, and activating the hazard warning signal, in the event of sensing either abnormally high temperature or rate of temperature rise, or both in the engine compartment and in each compartment where a combustion heater is located.
- 4.2. In addition to the fire alarm system, vehicles shall be equipped with a fire suppression system in the engine compartment and each compartment where a combustion heater is located.
- 4.3. The fire alarm system and the fire suppression system shall be automatically activated through a fire detection system. The detection alarm system shall be designed so as to detect a temperature in the engine compartment, and in each compartment where a combustion heater is located in excess of the temperature occurring during normal operation. There shall not be any false alarm.
- 4.4 The fire alarm system and the fire suppression system shall be operational irrespective of whether engine has been started and the vehicle's attitude.
- 4.5 The installation of the fire detection & suppression system shall comply with the following requirements;
- 4.5.1 The fire detection & suppression system shall be installed according to the system manufacturer's installation manual.

- 4.5.2 An analysis shall be conducted prior to the installation in order to determine the location and direction of suppression agent discharge point(s) (e.g. nozzles, extinguishing agent generators or extinguishing agent discharge tube or other distribution points). Potential fire hazards within the engine compartment and each compartment where a combustion heater is located, shall be identified and discharge point(s) located such that the suppression agent will be distributed to cover the fire hazard when the system activates. The spray pattern and direction of discharge points as well as the throwing distance shall be ensured to cover identified fire hazards. The system shall also be ensured to work properly regardless of the vehicle's altitude, road conditions etc.,

Fire hazards to be taken into account in the analysis shall at least consist of the following: Components whose surface may reach temperatures above the auto-ignition temperature for fluids, gases or substances that are present within the compartment and electrical components and cables with a current or voltage high enough for an ignition to occur as well as hoses and containers with flammable liquid or gas (in particular if those are pressurized). The analysis shall be fully documented.

- 4.5.3 The suppression system shall be scaled from the tested system, based on the total gross volume of the engine and auxiliary heater compartments where the system is to be installed. When measuring the engine compartment and the auxiliary heater compartment, the gross volume of these compartments shall be measured, i.e. the volume of the engine and its components shall not be subtracted. *

The scaling of the system includes the mass of the suppression agent, all discharge points and the mass of the propellant gas container, if applicable. The system pressure shall remain the same as in the tested system. If the system includes a discharge tube for the extinguishing agent, the length of the tube shall be scaled without nozzles. It is acceptable if the suppression system has more extinguishing agent and/or more discharge points and/or a longer discharge tube for the extinguishing agent and/or more propellant gas than required according to the scaling models found below.

If the gross volume of the engine and auxiliary heater compartments exceed 4 m³, the suppression system shall be scaled up using the following scaling factor calculated in equation (1) below. If the gross volume is less than 4 m³, it is allowed to scale down the suppression system using the scaling factor given in equation (2) below. S_x denotes the scaling factor and x denotes the total gross volume including the engine and combustion heater compartments [m³].

$$S_x = 0.1 \cdot x + 0.6 \dots(1)$$

$$S_x = 0.15 \cdot x + 0.4 \dots(2)$$

The scaled number of nozzles or other discharge points, if the suppression system has more than one discharge point may be rounded to the closest whole number.

* SP Technical Research Institute of Sweden 183 (SPRC 183) provides one method for calculation of Gross volume.

ANNEX I
(See 2.1.2)

**INFORMATION TO BE SUBMITTED FOR TYPE APPROVAL OF
BUSES WITH REGARD TO FIRE DETECTION AND ALARM SYSTEM**

S. No	Parameter	
1	Name of the Model(s)	
2	Variant(s)	
3	Vehicle category (s)	
4	Name and address of vehicle manufacturer	
5	Type of fire detector(s) used	
6	Name and address of manufacturer of the Fire detectors	
7	Test report number of the FDAS	
8	Description of the device or sketch showing location, relevant dimensions of fire detectors	
9	Devices provided additionally Acoustic or visual If visual, duration and type of optical signal	

ANNEX II
(See 2.2)
**INFORMATION TO BE SUBMITTED FOR TYPE APPROVAL OF
BUSES WITH REGARD TO FIRE DETECTION AND
SUPPRESSION SYSTEM**

S. No	Parameter	
1	Name of the Model(s)	
2	Variant(s)	
3	Vehicle category(s)	
4	Name and address of vehicle manufacturer	
5	Make and type of the fire suppression system	
6	Test report number of the FDSS	
7	Extinguishing agent (make and type):	
8	Mass of extinguishing agent:	
9	Type of discharge point(s):	
10	Length of discharge tube	
11	Number of discharge points(s):	
12	Type of propellant gas, if applicable:	
13	Pressure of propellant gas	
14	Minimum operating temperature	
15	Dimensions of pipes and fittings	
16	Detailed description, layout drawings and installation manual of the fire suppression system and its components	

ANNEX III

(See 2.2)

**INFORMATION TO BE SUBMITTED FOR COMPONENT LEVEL
APPROVAL OF FIRE DETECTION & ALARM SYSTEM AND FIRE
DETECTION & SUPPRESSION SYSTEM**

S. No	Parameter	
1	Make (trade name of manufacturer):	
2	Type and general commercial description:	
3	Name and address of manufacturer:	
4	Type of fire detector(s) used	
5	Name and address of manufacturer of the Fire detectors	
6	Description of the device or sketch showing location, relevant dimensions of fire detectors	
7	Devices provided additionally Acoustic or visual If visual, duration and type of optical signal	
8	Extinguishing agent (make and type):	
9	Mass of extinguishing agent:	
10	Type of discharge point(s):	
11	Length of discharge tube	
12	Number of discharge points(s):	
13	Type of propellant gas, if applicable:	
14	Pressure of propellant gas	
15	Minimum operating temperature	
16	Dimensions of pipes and fittings	
17	Detailed description, layout drawings and installation manual of the fire suppression system and its components	
18	Test report no. complying to FM/UL standard for each suppliers	

ANNEX IV

(See 2.1.5.1.1)

**REQUIREMENTS FOR FIRE DETECTION & ALARM
SYSTEM (FDAS) APPROVED AS A COMPONENT****1.0. Specifications**

- 1.1 Fire detection & alarm system (FDAS) conforming to this standard shall comply with the requirements of, low fire load described in Appendix 3.
- 1.2 The test apparatus, low test fire and general test conditions are described in Appendix 1.

2.0. Low fire load

- 2.1 The low fire load test shall be conducted in accordance with Appendix 3.
- 2.2 The detector/s will be mounted in the engine compartment in such a manner that there will be line of sight to at least one detector from any point surrounding the engine, in order to ensure optimal coverage of threats of fire liable to break out in the engine compartment.
- 2.3 The installation of the detectors will prevent mechanical damage that is liable to disrupt the operation thereof.
- 2.4 The command and control system will be mounted outside of the engine compartment, if possible.
- 2.5 The manual means of activation and warning will be positioned in the vicinity of the driver's dashboard.
- 2.6 The fire shall be detected and warning signal shall be activated within 10 seconds after ignition.
- 2.7 The test is considered passed if success was achieved at the first attempt or at two of three attempts in a case when first of these attempts fails.

ANNEX V
(See 2.6.1.1)

**REQUIREMENTS FOR FIRE DETECTION &
SUPPRESSION SYSTEM (FDSS) APPROVED AS A
COMPONENT**

1.0. Specifications

- 1.1. Fire detection & suppression system (FDSS) conforming to this standard shall comply with the requirements of high fire load, low fire load, high fire load with fan and re-ignition described in Appendix 1.
- 1.2. The test apparatus, test fires and general test conditions are described in Appendix 1.

2.0. High fire load

- 2.1 The high fire load test shall be conducted in accordance with Appendix 2.
- 2.2 The detector/s will be mounted in the engine compartment in such a manner that there will be line of sight to at least one detector from any point surrounding the engine, in order to ensure optimal coverage of threats of fire liable to break out in the engine compartment.
- 2.3 The installation of the detectors will prevent mechanical damage that is liable to disrupt the operation thereof.
- 2.4 The command and control system will be mounted outside of the engine compartment, if possible.
- 2.5 The manual means of activation and warning will be positioned in the vicinity of the driver's dashboard, in such a manner that the driver will be able to see, hear and activate them, and such will be connected to the command and control system of the extinguishing system.
- 2.6 The fire shall be detected and warning signal shall be activated within 10 seconds after ignition.
- 2.7 The test shall be conducted with the extinguishing agent and the propellant gas vessel or the suppression agent generator cooled to the minimum operating temperature ("0" degrees celsius) for the fire suppression system, as declared by the manufacturer.
- 2.8 The fires shall be fully extinguished, either, in the minute after activation or upon end of the discharge of the suppression system.
- 2.9 The test is considered passed either after success at first attempt or at two of three attempts in a case when first of these attempts fails.

3.0. Low fire load

- 3.1 The low fire load test shall be conducted in accordance with Appendix 3.
- 3.2 The detector/s will be mounted in the engine compartment in such a manner that there will be line of sight to at least one detector from any point surrounding the engine, in order to ensure optimal coverage of threats of fire liable to break out in the engine compartment.

- 3.3 The installation of the detectors will prevent mechanical damage that is liable to disrupt the operation thereof.
- 3.4 The command and control system will be mounted outside of the engine compartment, if possible.
- 3.5 The manual means of activation and warning will be positioned in the vicinity of the driver's dashboard, in such a manner that the driver will be able to see, hear and activate them, and such will be connected to the command and control system of the extinguishing system.
- 3.6 The fire shall be detected and warning signal shall be activated within 10 seconds after ignition.
- 3.7 The test shall be conducted with the extinguishing agent and the propellant gas vessel or the suppression agent generator cooled to the minimum operating temperature ("0" degrees celsius) for the fire suppression system, as declared by the manufacturer.
- 3.8 The fires shall be fully extinguished either in the minute after activation or upon end of the discharge of the suppression system.
- 3.9 The test is considered passed if success was achieved at the first attempt or at two of three attempts in a case when first of these attempts fails.

4.0. High fire load with fan

- 4.1 The high fire load test with fan shall be conducted in accordance with Appendix 4.
- 4.2. The detector/s will be mounted in the engine compartment in such a manner that there will be line of sight to at least one detector from any point surrounding the engine, in order to ensure optimal coverage of threats of fire liable to break out in the engine compartment.
- 4.3. The installation of the detectors will prevent mechanical damage that is liable to disrupt the operation thereof.
- 4.4 The command and control system will be mounted outside of the engine compartment, if possible.
- 4.5 The manual means of activation and warning will be positioned in the vicinity of the driver's dashboard, in such a manner that the driver will be able to see, hear and activate them, and such will be connected to the command and control system of the extinguishing system.
- 4.6 The fire shall be detected and warning signal shall be activated within 10 seconds after ignition.
- 4.7 The test shall be conducted with the extinguishing agent and the propellant gas vessel or the suppression agent generator cooled to the minimum operating temperature ("0" degrees celsius) for the fire suppression system, as declared by the manufacturer.
- 4.8 The fires shall be fully extinguished either in the minute after activation or upon end of the discharge of the suppression system.

4.9 The test is considered passed if success was achieved at the first attempt or at two of three attempts in a case when first of these attempts fails.

5.0. Re-ignition test

5.1. The re-ignition test shall be conducted in accordance with Appendix 5.

5.2. The fire shall be fully extinguished and no re-ignition shall occur 45 seconds after the extinguishing of the fire.

5.3. The test is considered passed either if success was achieved at the first attempt or at two of three attempts in a case when first of these attempts fails.

ANNEX VI
(See 2.1.5.1.2)

**REQUIREMENTS FOR FIRE DETECTION & ALARM
SYSTEM (FDAS) INSTALLED IN A SPECIFIC ENGINE
COMPARTMENT**

1.0 Specifications

- 1.1 A specific engine compartment means engine compartments which do not differ in the following essential aspects:
- (a) Engine compartments position in the vehicle;
 - (b) Maximum gross volume;
 - (c) General layout of components in the compartment (i.e. position of fire hazards determined).

For compartments where a combustion heater is placed aspects (b) and (c) apply.

- 1.2 The fire detection & alarm system (FDAS) conforming to this standard shall comply with the requirements of low fire load, described in Appendix 3.

- 1.3 The test apparatus, test fires and general test conditions are described in Appendix 1.

In order to facilitate the positioning of the fire trays within the engine and combustion heater compartment additional supports may be used and the height of the prescribed test fire may be lowered to a minimum of 40 mm.

The test conditions in Appendix 3 may be adapted for the specific engine compartment and combustion heater compartment. The adaptation shall provide an equivalent level of safety. The principles for the adaptation shall be verified by the Test Agency responsible for the tests. The principle of adaption shall be documented and added to the test report.

2.0 Low fire load

- 2.1 The low fire load test shall be conducted in accordance with Appendix 3.

- 2.2 The fire shall be detected and warning signal shall be activated within 10 seconds after ignition.

- 2.3 The test is considered passed either after success at the first attempt or after success at the second and third attempts in case of failure at the first attempt.

ANNEX VII

(See 2.6.1.2)

**REQUIREMENTS FOR FIRE DETECTION &
SUPPRESSION SYSTEM (FDSS) INSTALLED IN
A SPECIFIC ENGINE COMPARTMENT****1.0. Specifications**

1.1. A specific engine compartment means engine compartments which do not differ in the following essential aspects:

- (a) Engine compartments position in the vehicle;
- (b) Maximum gross volume;
- (c) General layout of components in the compartment (i.e. position of fire hazards determined).

For compartments where a combustion heater is placed aspects (b) and (c) apply.

1.2 The fire detection & suppression system (FDSS) conforming to this standard shall comply with the requirements of high fire load, low fire load, high fire load with fan (to be applied if a fan is fitted in the engine compartment and/or combustion heater compartment) and re-ignition described in Appendix 1.

1.3 The test apparatus, test fires and general test conditions are described in Appendix 1.

In order to facilitate the positioning of the fire trays within the engine and combustion heater compartment additional supports may be used and the height of the prescribed test fire may be lowered to a minimum of 40 mm.

The test conditions in Appendices 2 to 5 may be adapted for the specific engine compartment and combustion heater compartment. The adaptation shall be based on the provisions given in Part II, Clause nos. 4.5.1, 4.5.2 and 4.5.3, determining the fire hazards within the compartment and the scaling of the fire suppression system. The adaptation shall provide an equivalent level of safety. The principles for the adaptation shall be verified by the Test Agency responsible for the tests. The principle of adaption shall be documented and added to the test report.

2.0 High fire load

2.1 The high fire load test shall be conducted in accordance with Appendix 2.

2.2 The test shall be conducted with the extinguishing agent and the propellant gas vessel or the suppression agent generator cooled to the minimum operating temperature ("0" degrees celsius) for the fire suppression system, as declared by the manufacturer.

2.3 The fire shall be detected and warning signal shall be activated within 10 seconds after ignition.

2.4 The fires shall be fully extinguished, either, in the minute after activation or upon end of the discharge of the suppression system.

2.5 The test is considered passed either after success at the first attempt or after success at the second and third attempts in case of failure at the first attempt.

3.0 Low fire load

- 3.1 The low fire load test shall be conducted in accordance with Appendix 3.
- 3.2 The fire shall be detected and warning signal shall be activated 10 seconds after ignition.
- 3.3 The fires shall be fully extinguished either in the minute after activation or upon end of the discharge of the suppression system.
- 3.4 The test is considered passed either after success at the first attempt or after success at the second and third attempts in case of failure at the first attempt.

4.0 High fire load with fan (if a fan is fitted in the engine and/or combustion heater compartment)

- 4.1 The high fire load test with fan shall be conducted in accordance with Appendix 4.
- 4.2 The fire shall be detected and warning signal shall be activated within 10 seconds after ignition.
- 4.3 The fires shall be fully extinguished either in the minute after activation or upon end of the discharge of the suppression system.
- 4.4 The test is considered passed either after success at the first attempt or after success at the second and third attempts in case of failure at the first attempt.

5.0 Re-ignition test

- 5.1 The re-ignition test shall be conducted in accordance with Appendix 5.
- 5.2 The fire shall be fully extinguished and no re-ignition shall occur 45 seconds after the extinguishing of the fire.
- 5.3 The test is considered passed either after success at the first attempt or after success at the second and third attempts in case of failure at the first attempt.

ANNEX VIII
(See 3.0 of Parts I & II)

GUIDELINES FOR DECIDING WHETHER TESTING IS NEEDED

1. In general, when changes in technical specifications of vehicle do not affect the FDAS / FDSS performance adversely, and is still within the stipulated limits, the type approval certificate can be extended. The changes in parameters that affect the FDAS / FDSS performance are listed in clause no. 2.
2. In the case of following changes, with respect to the vehicles tested, in the details submitted as per Annexures I & II, tests are necessary for establishing compliance:

1	Change in volume of engine compartment	To be tested if volume of engine compartment is increased which increases the number of nozzles derived from clause no. 4.5.3
2	Type of extinguishing agents	To be tested in case of any change
3	Change in capacity of extinguishing agent	To be tested in case of decrease in capacity
4	Dimensions of pipes & fittings of FDSS & FDAS	To be tested in case of any change
5	Pressurized cartridge system	To be tested in case of decrease in pressure of the system

3. Changes other than the above are generally considered as not affecting compliance. However it does not limit test agencies and vehicle manufacturer to investigate possibility of any other criteria, for which tests may be conducted for extension as per mutual agreement between test agencies & vehicle manufacturer.

Appendix 1

Test apparatus, test fires and general test specifications

1.0 Test apparatus

- 1.1. The test apparatus is to be made of steel plate. The thickness of the steel plate shall be in accordance with Table 1. Figure 1 shows the test apparatus from the front side, Figure 2 from the rear side and Figure 3 from top. The front side of the test apparatus simulates the rear side of a real engine compartment. Test apparatus shall have its own fire suppression systems which can extinguish the test fire in case the FDAS test and also in case the FDSS under test fails to suppress the test fire.

Figure 1
Coordinate system for the position of objects in test apparatus
(view from front side)

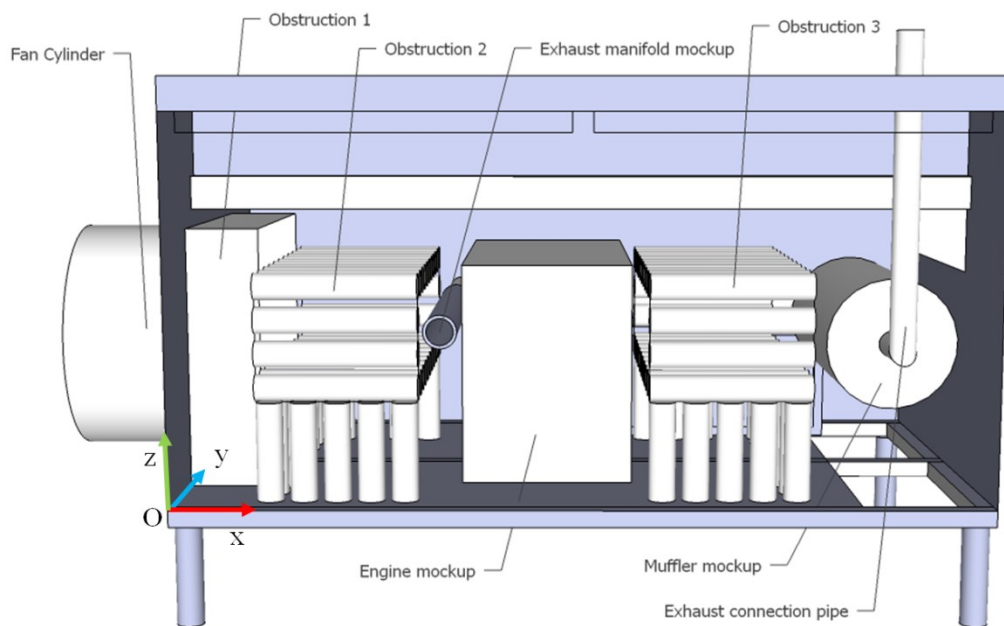

Figure 2
Test apparatus seen from the rear

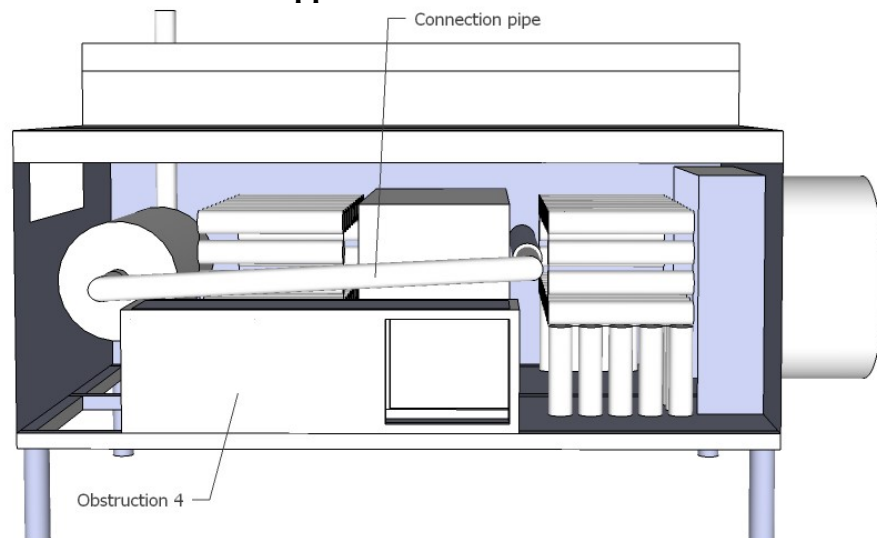

Figure 3
Test apparatus seen from Top

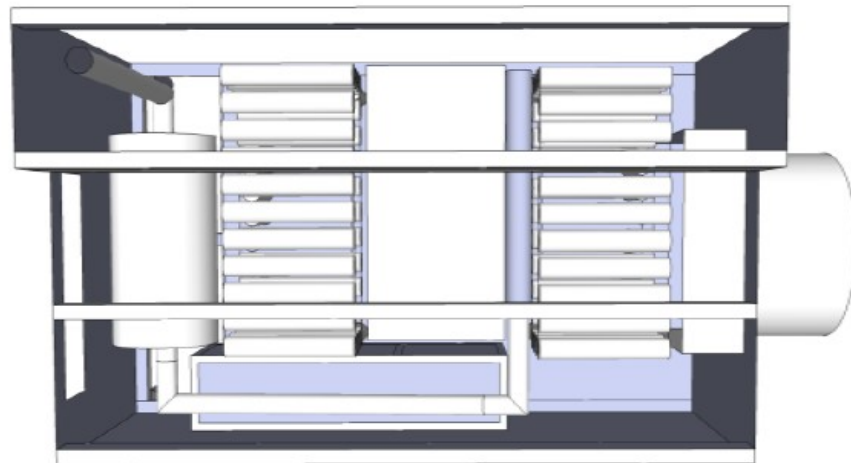

Table 1
Test apparatus objects

Objects	Plate thickness
Fan cylinder	1.5 – 2 mm
Obstructions	1.5 – 2 mm
Exhaust manifold mock-up	8 mm
Engine mock-up	2 – 3 mm
Muffler mock-up	2 – 3 mm
Exhaust pipe	2 – 3 mm
Connection pipe	2 – 3 mm
Walls, ceiling and floor	1.5 – 3 mm

1.2. Object locations

- 1.2.1 All objects in the test apparatus are positioned according to coordinates (x, y, z) as shown in Table 2. Origin is the position marked (O) in Figure 1. The value of the coordinates is the distance in meter from origin (see Figure 1), i.e. left-front-bottom corner.

Table 2
Coordinates of objects

Objects	Coordinates [x; y; z]
Fan cylinder	[-0.60; 0.40; 0.10]
Obstruction 1	[0.0; 0.26; 0.0]
Obstruction 2	[0.26; 0.05; 0.02]
Exhaust manifold mock-up	[0.76; 0.05; 0.47]
Engine mock-up	[0.87; 0.05; 0.04]
Obstruction 3	[1.44; 0.05; 0.02]
Obstruction 4	[0.82; 1.2; 0.0]
Muffler mock-up	[2.0; 0.28; 0.23]

1.3 Framework

- 1.3.1 The framework of the test apparatus shall be constructed according to Figure 4. The sizes of the beams are 50 mm × 50 mm and 100 mm × 50 mm respectively. The framework shall be 300 mm above the ground.

Figure 4
Framework for the test apparatus

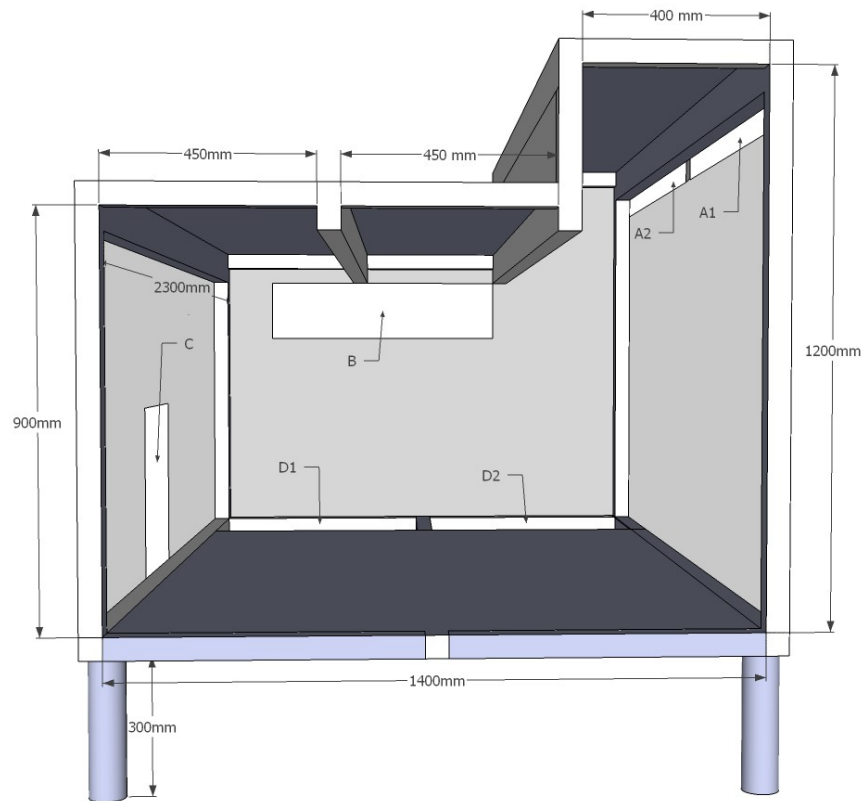

1.4. Apertures

- 1.4.1. In addition to the opening for the fan, the test apparatus includes six apertures. The dimensions and positions of the apertures are given according to the coordinates in Table 3. The positions are given by referring to two diagonally opposite corners (all apertures are rectangular in shape). The apertures are shown in Figure 4.

Table 3
Coordinates of apertures in the test apparatus

Aperture	Coordinates [x; y; z] – [x; y; z]	Area of aperture
A1	[0.03; 0.00; 1.08] – [1.18; 0.00; 1.13]	0.06 m ²
A2	[1.22; 0.00; 1.08] – [2.37; 0.00; 1.13]	0.06 m ²
B	[2.40; 0.50; 0.70] – [2.40; 1.30; 0.90]	0.16 m ²
C	[0.85; 1.50; 0.03] – [1.24; 1.50; 0.36]	0.13 m ²
D1	[2.00; 0.05; 0.00] – [2.35; 0.73; 0.00]	0.27 m ²
D2	[2.00; 0.78; 0.00] – [2.35; 1.20; 0.00]	0.26 m ²
Total area of aperture:		0.94 m ²

1.5 Fan

- 1.5.1 An axial fan with a diameter of 710 mm shall be mounted on the left side of the fan cylinder. The diameter of the cylinder shall be equal to the diameter of the fan. The fan shall produce a certain rate of air flow through the cylinder according to the test scenarios in Appendices 2 to 5. A frequency converter may be used to adjust the fan speed.

1.6 Mock-up components

1.6.1 The dimensions of the engine mock-up are 1,000 mm × 650 mm × 500 mm. The dimensions of the muffler mock-up are Ø400 mm × 800 mm. The exhaust manifold mock-up shall have the inner dimensions of Ø80 mm × 900 mm. The mock-up components shall be hollowed. The exhaust manifold mock-up shall be connected to the muffler mock-up through a pipe with a diameter of 76 mm. A pipe from the muffler mock-up should also be used to carry the exhaust gases from the pre-warming system out from the test apparatus.

1.7 Thermocouples

1.7.1 The entry and exit of the detection pipe of the test rig shall be at the top of test rig only. Seven thermocouples (Tc) shall be mounted on the exhaust manifold mock-up, drilled 2 mm into the tube from the outside. Thermocouples Tc1 to Tc4 shall be located on top of the mock-up at the distances from the mock-up inlet according to Table 4. Thermocouples Tc5 to Tc7 shall be located around the mock-up at the same distance from the inlet as Tc2. The location of the thermocouples is illustrated in Figures 5 and 6.

Table 4
Distance to thermocouple from inlet of exhaust manifold mock-up

Thermocouple	Distance from inlet
Tc1	250 mm
Tc2	300 mm
Tc3	350 mm
Tc4	600 mm
Tc5	300 mm
Tc6	300 mm
Tc7	300 mm

Figure 5
Thermocouples on the exhaust manifold mock-up

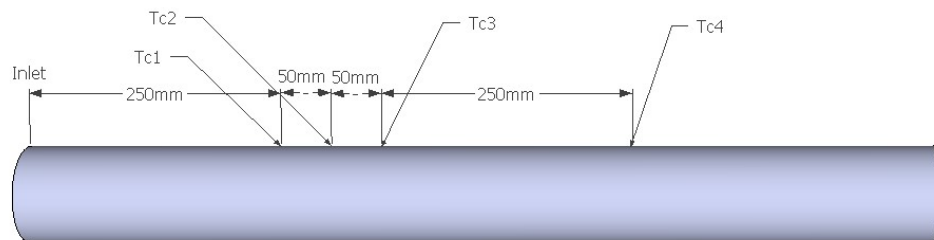
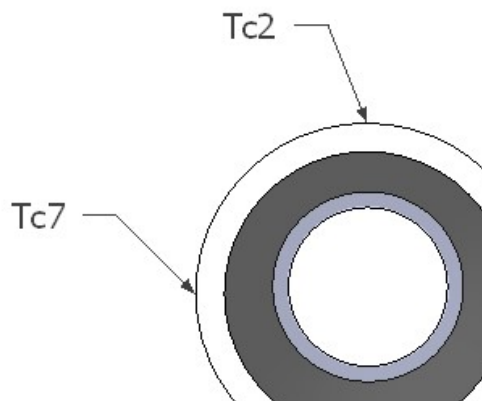

Figure 6
Thermocouples on the exhaust manifold mock-up
(the inlet of the mock-up is on the left side)



1.8 Propane burner

1.8.1 The propane burner used to pre-warm the exhaust system shall be chosen as to fulfill the requirements on achieved temperatures specified in paragraph 3.4.6.

1.9 Obstructions

1.9.1. Obstruction 1 has the dimensions of 900 mm × 840 mm × 230 mm, as shown in Figure 7. Obstructions 2 and 3 consist of horizontal and vertical obstruction tubes as shown in Figure 8. The horizontal obstruction tubes are closed and hollow, with a diameter of 80 mm and a length of 480 mm. The vertical tubes are hollow and open in the bottom, with a diameter of 80 mm and a length of 230 mm. The open distance between every tube is 20 mm. Obstruction 4 is a box measuring 1,250 mm × 300 mm × 390 mm as shown in Figure 9.

Figure 7
Obstruction 1

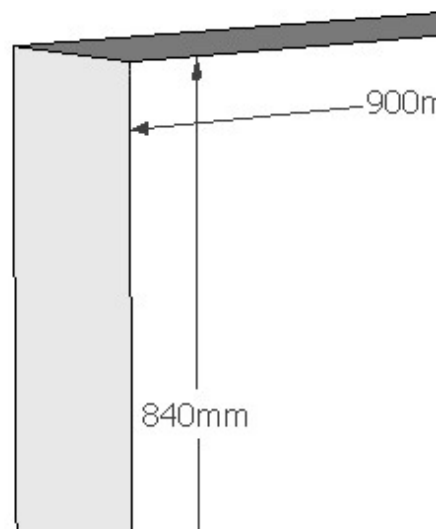
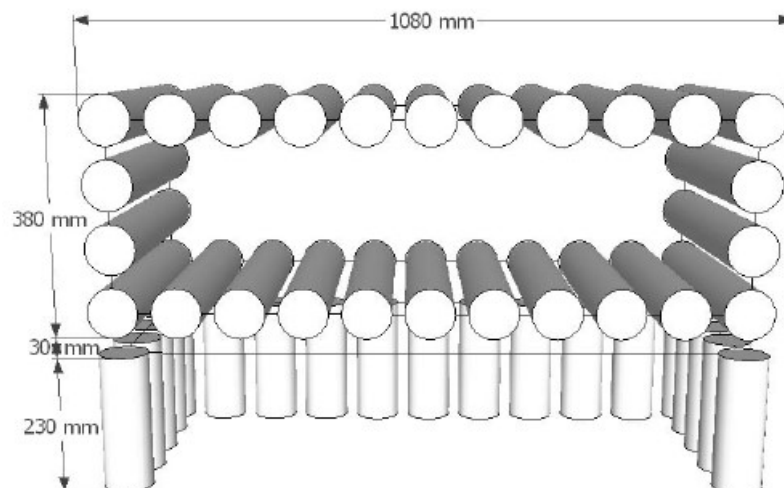
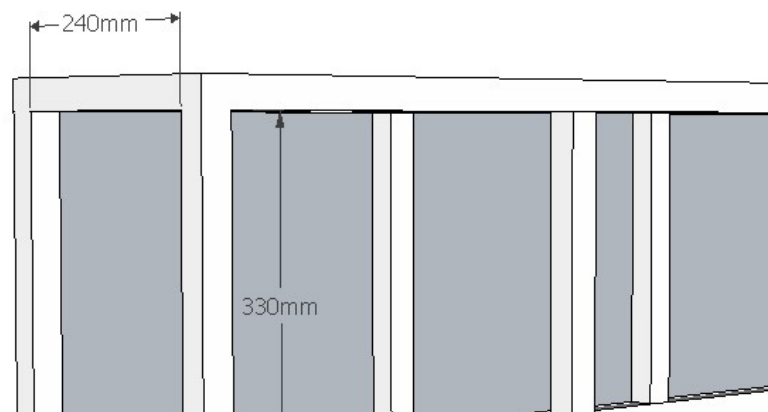

Figure 8
Obstruction 2 and 3



**Figure 9
Obstruction 4**



1.10. Pool Fire trays

1.10.1 The square pool fire trays with fibreboards and the rectangular pool fire trays shall be positioned in its orientation according to the test scenarios in Appendices 2 to 4. Figure 10 shows the dimensions for test fire #2. The test fire shall be positioned perpendicular to the long edge of the test apparatus.

**Figure 10
Distances for test fire #2**

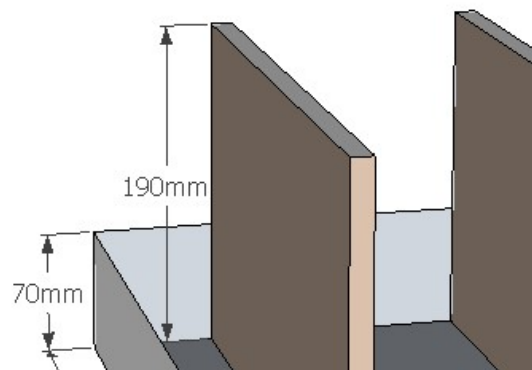

2.0 Test fires

2.1. The test fires in Table 5 are to be used in the different test scenarios described in Appendices 2 to 5. Diesel oil (commercial fuel oil or light diesel oil), heptane (C₇H₁₆) and engine oil 15W-40 with a flash point COC of 230 °C and viscosity at 40 °C of 107 mm²/s shall be used as test fuels.

**Table 5
Test fires**

Test fire	Description	Fuel	Approximate peak Heat Release Rate 60 sec after ignition
#1	Pool fire 300 mm × 300 mm	Diesel oil and heptane	60 kW
#2	Pool fire 300 mm × 300 mm and 2 fibreboards	Diesel oil and heptane	110 kW
#3	Pool fire 200 mm × 300 mm	Diesel oil and heptane	40 kW
#4	Pool fire Ø 150 mm	Diesel oil and heptane	7 kW
#5	Spray fire (450 kPa, 0.73 kg/min ±10%)	Diesel oil	520 kW
#6	Spray fire (450 kPa, 0.19 kg/min ±10%)	Diesel oil	140 kW
#7	Dripping oil fire (40 droplets/min ±10)	Engine oil	5 kW

- 2.2 Three different types of pool fire trays are applied in Table 5: square, rectangular and circular. Detailed descriptions of these trays are given in Table 6.

Table 6
Specification of pool fire trays

Dimensions	Rim height	Nominal thickness	Used for test fire
300 mm × 300 mm	70 mm	1.5 mm	#1, #2
200 mm × 300 mm	70 mm	2 mm	#3
Ø 150 mm	100 mm	1.5 mm	#4

- 2.3 The amount of water, diesel and heptane used in the tests should be in accordance with Table 7.

Table 7
Amount of fuel used in pool fire trays

Dimensions	Water	Diesel	Heptane	Used for test fire
300 mm × 300 mm	1.0 l	0.5 l	0.2 l	#1, #2,
200 mm × 300 mm	0.5 l	0.5 l	0.2 l	#3
Ø 150 mm	0.2 l	0.2 l	0.1 l	#4

- 2.4. Test fire #2 consists of a heptane pool and two diesel soaked fibreboards with a dry density of 3.5 kg/m³. The dimensions of the fibreboards shall be 12 mm × 295 mm × 190 mm. The fibreboards shall consist of at least 90 per cent raw material from wood. The moisture content in the boards before they are soaked in diesel oil shall not exceed 7 per cent.

The fibreboards shall be completely immersed in diesel oil for at least 10 minutes prior to the test and mounted vertically in the pool fire tray not more than 10 minutes before the start of the test.

- 2.5 Test fire #5 and #6 consist of diesel oil spray fires while Test fire #7 consists of a dripping oil fire (by hot surface ignition).

The spray nozzle for test fire #5 shall be a Lechler 460.368.30 or an equivalent. The spray nozzle for test fire #6 shall be a Lechler 212.245.11 or an equivalent. The spray nozzle for test fire #7 shall be a Danfoss 0.60X80H or an equivalent.

3.0 Installation of fire suppression system

- 3.1 To obtain the minimum discharge rate condition, an extinguishing system is to be assembled using its maximum piping limitations with respect to the number of fittings and size and length of pipe, if relevant. The cylinder is to be used with its rated capacity and the cylinder or gas cartridge pressurized with propellant gas to the normal operating pressure, if relevant.

3.2 The fire suppression system shall be installed by the system manufacturer or supplier. It shall be the responsibility of suppliers to get heat detecting sensor approval complying with Factory Manual (FM 3210) or UL 521 standard requirements. Figure 11 shows the area where extinguishing agent discharge points such as of nozzles, extinguishing agent generators or extinguishing agent discharge tubes may be located. The discharge points shall be positioned inside the test apparatus, at two different areas:

(a) In the ceiling and at the rear wall. Discharge points positioned in the ceiling shall be positioned at a minimum of 750 mm above the floor level ($z \geq 0.75$) and outside of Obstruction 1. Nozzles positioned at the rear wall shall be positioned within 350 mm from the rear wall ($y \geq 1.15$) and minimum 450 mm from the floor level ($z \geq 0.45$). Figures 17 and 18 show the area where the nozzles may be located.

(b) Inside the small box (referred to as Obstruction 4) in the rear side of the test apparatus. Nozzles should be located in the ceiling of the box with a minimum of 290 mm from the floor ($z \geq 0.29$).

Figure 11
Nozzle positioning seen from the rear side of test apparatus

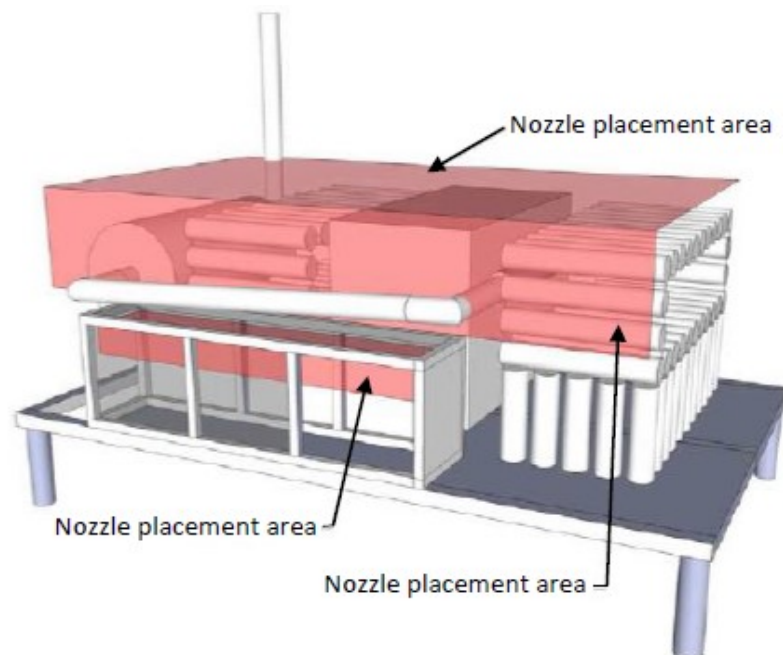

3.3 The system set-up and configuration shall be observed and documented prior to the test (e.g. amount of suppression agent and propellant gas, system pressure, number, type and location of discharge points, length of pipes and number of fittings).

Temperature shall be measured during the re-ignition tests at locations specified in Appendix 1.

3.4 Practical conduct of a test

3.4.1 The pool fire trays are to be filled with diesel and heptane on a base of water according to Table 7. If fibreboards are to be used as a fire source, the fibreboards shall be soaked in diesel oil, prior to the test, according to instructions in paragraph 2.4.

- 3.4.2 A pre-burn time based on the information in Appendices 2 to 5 is required. The pre-burn time is measured beginning from the time the first fire is ignited. All pool fires in the test scenarios shall be ignited within the allowed ignition-time, according to Appendices 2 to 5, using a suitable ignition source. The low fire load scenario in Appendix 3 may be performed either with one test fire at a time or the test fires combined with the suppression system showing its ability to extinguish all test fires, separately or merged.
- 3.4.3 A fan is used in some of the test scenarios to obtain a specific air flow rate into the test apparatus. The fan shall be engaged 30 seconds before the suppression system is activated. The fan shall remain active until the test is complete, i.e. until it is determined whether the test is passed or failed.
- 3.4.4. A diesel spray is used in some of the test scenarios. The diesel spray shall be activated 10 seconds prior to activation of the suppression system. The diesel spray shall remain active until the test is completed, i.e. until it is clarified if the test is passed or failed.
- 3.4.5 After the stipulated pre-burn time, the suppression system shall be manually or automatically activated.
- 3.4.6 In test for re-ignition, the exhaust manifold mock-up tube is pre-heated prior to the test with a burner. Pressurized air may be added to the flame for better combustion. The tube shall be heated from the inner side until the temperature of Tc2 is above 600 °C and Tc1 is above 570 °C and the temperatures of Tc5, Tc6 and Tc7 not are less than 520 °C. When the predefined temperatures are reached the pre-heating procedure stops. After 30 seconds the engine oil start dripping and the suppression system activates 15 seconds later. The engine oil shall ignite before activation of the suppression system. The oil should continue to drip on to the tube until it is clarified if the test is passed or failed.

4.0 Tolerances

- 4.1. A tolerance of ± 5 per cent of the stipulated values shall apply (for time values: ± 5 seconds).

Appendix 2

High fire load scenario

Table 1
Test fires in high fire load scenario

Test fire (see Table 5 in Appendix 1)	Description	Coordinates [x; y; z] (see Figure 1 in Appendix 1)
#6	Spray fire (4.5 bar, 0.19 kg/min)	[1.47; 0.73; 0.46]
#3	Pool fire 200 mm × 300 mm	[0.97; 0.85; 0.70]
#4	Pool fire Ø 150 mm	[0.97; 1.28; 0.00]
#3	Pool fire 200 mm × 300 mm	[1.54; 0.57; 0.36]
#2	Pool fire 300 mm × 300 mm and 2 Fibreboards	[1.54; 0.77; 0.36]
#3	Pool fire 200 mm × 300 mm	[1.54; 0.13; 0.00]

Note: The fan is not used

Table 2
Test procedure for high fire load scenario

Time	Action
00:00	Start igniting
00:10	Alarm should have activated*
01:20	Ignition complete
01:50	Start of Diesel spray
02:00	Manual activation of suppression system
02:30	FDSS should have suppressed the Fire

* Time in seconds after which alarm activates shall be recorded in the test report

Figure 1
Test fire positioning, view from the front side

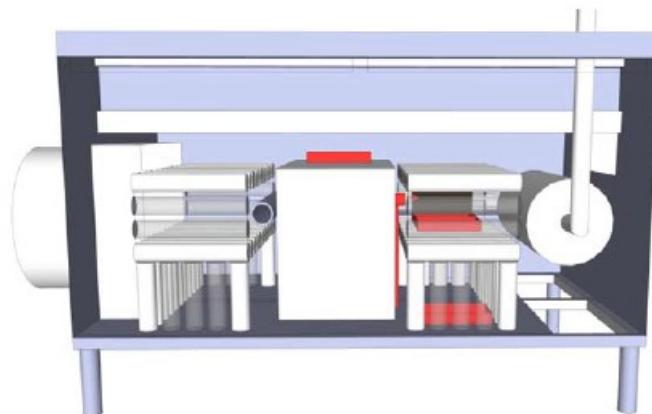
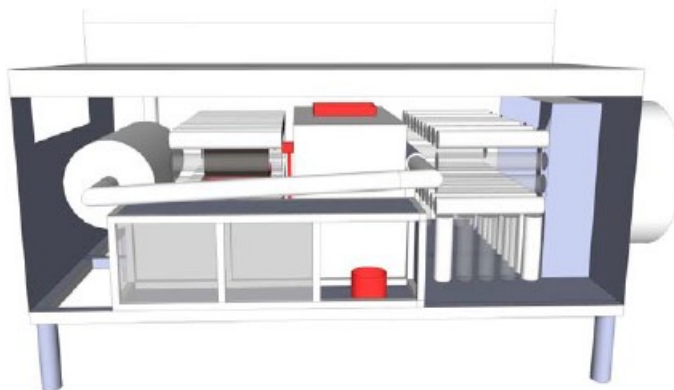

Figure 2
Test fire positioning, view from the rear side



Appendix 3

Low fire load scenario

Table 1
Test fires in low fire load scenario

Test fire (see Table 5 in Appendix 1)	Description	Coordinates [x; y; z] (see Figure 1 in Appendix 1)
#4	Pool fire Ø 150 mm	[0.02; 0.08; 0.00]
#3	Pool fire 200 mm × 300 mm	[0.37; 0.57; 0.00]
#4	Pool fire Ø 150 mm	[0.45; 1.20; 0.00]
#4	Pool fire Ø 150 mm	[0.97; 1.28; 0.00]
#4	Pool fire Ø 150 mm	[1.54; 0.57; 0.00]

Note: The fan is producing an air flow of 1.5 m³/s.

Table 2A
**Test in Table 2A is intended for checking automatic activation of
 Suppression system.**

Time	Action
00:00	Start igniting
00:10	Alarm & fire suppression should have activated automatically.*

* Time in seconds after which alarm activates shall be recorded in the test report.

Table 2B
Test in Table 2B is applicable for Low fire load scenario

Time	Action
00:00	Start igniting
00:10	Alarm should have activated*
01:00	Ignition complete
01:30	Start the Fan
02:00	Manual activation of suppression system
02:30	FDSS should have suppressed the Fire

* Time in seconds after which alarm activates shall be recorded in the test report.

Figure 1
Test fire positioning, view from the front side

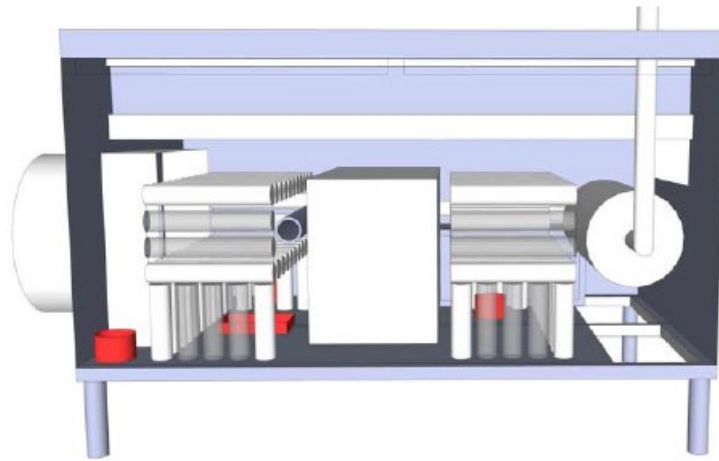
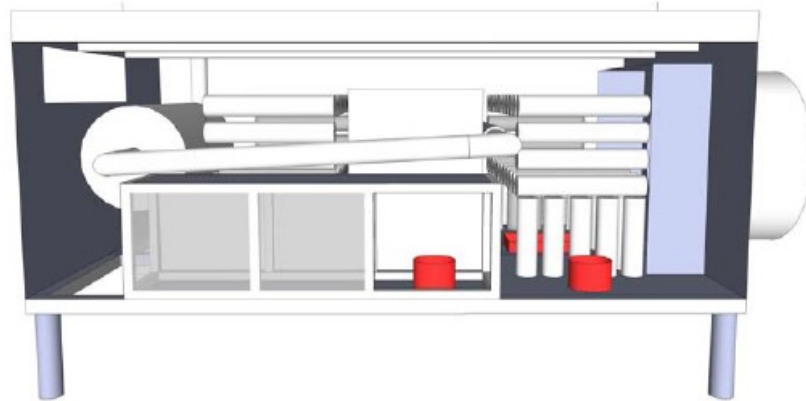

Figure 2
Test fire positioning, view from the rear side



Appendix 4 High fire load scenario with fan

Table 1
Test fires in high fire load scenario with fan

Test fire (see Table 5 in Appendix 1)	Description	Coordinates [x; y; z] (see Figure 1 in Appendix 1)
#5	Spray fire (4.5 bar, 0.73 kg/min)	[0.37; 0.70; 0.46]
#1	Pool fire 300 mm × 300 mm	[0.37; 0.47; 0.36]
#2	Pool fire 300 mm × 300 mm and 2 fibreboards	[0.37; 0.77; 0.36]
#1	Pool fire 300 mm × 300 mm	[0.37; 0.13; 0.00]
#1	Pool fire 300 mm × 300 mm	[1.54; 0.13; 0.00]

Note: The fan is producing an air flow of 1.5m³/s.

Table 2
Test procedure for high fire load scenario with fan

Time	Action
00:00	Start igniting
00:10	Alarm should have activated*
01:00	Ignition complete
01:30	Start the Fan
01:45	Start of diesel spray
02:00	Manual activation of suppression system
02:30	FDSS should have suppressed the Fire

* Time in seconds after which alarm activates shall be recorded in the test report.

Figure 1
Test fire positioning, view from the front side

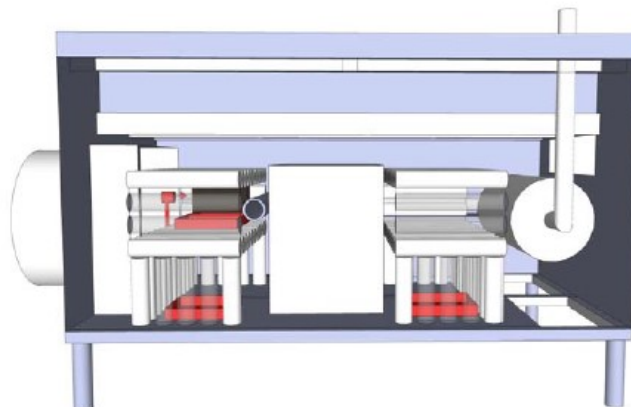

Appendix 5 Re-ignition scenario

Table 1
Test fires in re-ignition scenario

Test fire (see Table 5 in Appendix 1)	Description	Coordinates [x; y; z] (see Figure 1 in Appendix 1)
#7	Dripping oil fire (2 bar, 0.01 kg/min)	[0.82; 0.28; 1.22]

Note: The fan is not used.

Table 2
Test procedure for re-ignition scenario

Time	Action
Prior to test	Pre-heat tube
00:00	Predefined temperatures are reached
00:30	Start oil dripping
00:45	FDSS should have activated suppression system & suppressed the fire

Figure 1
Test fire positioning, view from the front side

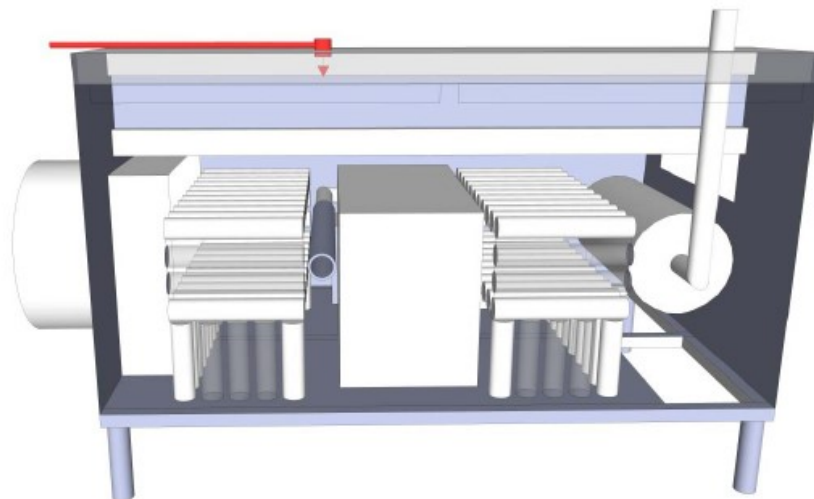

ANNEX IX
(See Introduction)
COMPOSITION OF AISC PANEL*

Convener	
Shri D. Balakrishnan / Shri Arun S. (Former Convener)	SIAM (Ashok Leyland Ltd.) SIAM (Hero Moto Corp Ltd.)
Members	Representing
Shri M. Sreenivasulu	ARAI
Shri V. A. Tandon	ARAI
Shri V. S. Khairatkar	ARAI
Shri V. P. Rawal	ARAI
Shri V. D. Chavan	CIRT
Representative from	ICAT
Representative from	IIP
Representative from	VRDE
Shri S Ravishankar	SIAM (Ashok Leyland Ltd)
Shri H Sundarakumar	SIAM (Ashok Leyland Ltd)
Shri V Faustino	SIAM (Ashok Leyland Ltd)
Shri Girish S Kodolikar	SIAM (Force Motors Ltd.)
Shri V.G. Kulkarni	SIAM (Mahindra Truck & Buses)
Shri Bhole S. S.	SIAM (Tata Motors Ltd.)
Shri Karthik Sarma	SIAM (Volvo Buses India Pvt. Ltd.)
Shri Saahil Saxena	SIAM (VE Commercial Vehicles Ltd.)
Shri Uday Harite	ACMA

* At the time of approval of this Automotive Industry Standard (AIS)

ANNEX X
(See Introduction)
COMMITTEE COMPOSITION *
Automotive Industry Standards Committee

Chairperson	
Mrs. Rashmi Urdhwareshe	Director The Automotive Research Association of India, Pune
Members	Representing
Representative from	Ministry of Road Transport and Highways (Dept. of Road Transport and Highways), New Delhi
Representative from	Ministry of Heavy Industries and Public Enterprises (Department of Heavy Industry), New Delhi
Shri S. M. Ahuja	Office of the Development Commissioner, MSME, Ministry of Micro, Small and Medium Enterprises, New Delhi
Shri Shrikant R. Marathe	Former Chairman, AISC
Shri N. K. Sharma	Bureau of Indian Standards, New Delhi
Director/ Shri D. P. Saste (Alternate)	Central Institute of Road Transport, Pune
Director	International Centre for Automotive Technology, Manesar
Director	Indian Institute of Petroleum, Dehra Dun
Director	Vehicles Research and Development Establishment, Ahmednagar
Representatives from	Society of Indian Automobile Manufacturers
Shri T. R. Kesavan	Tractor Manufacturers Association, New Delhi
Shri Uday Harite	Automotive Components Manufacturers Association of India, New Delhi

Member Secretary
Shri A. S. Bhale
General Manager
The Automotive Research Association of India, Pune

* At the time of approval of this Automotive Industry Standard (AIS)