

AUTOMOTIVE INDUSTRY STANDARD

**Requirements for the Protection of
Pedestrian and other Vulnerable
Road Users in the event of a Collision
with a Motor Vehicle**

PRINTED BY
THE AUTOMOTIVE RESEARCH ASSOCIATION OF INDIA
P.B. NO. 832, PUNE 411 004

ON BEHALF OF
AUTOMOTIVE INDUSTRY STANDARDS COMMITTEE

UNDER
CENTRAL MOTOR VEHICLE RULES – TECHNICAL STANDING COMMITTEE

SET-UP BY
MINISTRY OF ROAD TRANSPORT and HIGHWAYS
GOVERNMENT OF INDIA

April 2024

INTRODUCTION

The Government of India felt the need for a permanent agency to expedite the publication of standards and development of test facilities in parallel when the work of preparation of standards is going on, as the development of improved safety critical parts can be undertaken only after the publication of the standard and commissioning of test facilities. To this end, the erstwhile Ministry of Surface Transport (MoST) has constituted a permanent Automotive Industry Standard Committee (AISC) vide order no. RT-11028/11/97-MVL dated September 15, 1997. The standards prepared by AISC will be approved by the permanent CMVR Technical Standing Committee (CTSC). After approval, The Automotive Research Association of India, (ARAI), Pune, being the secretariat of the AIS Committee, has published this standard. For better dissemination of this information, ARAI may publish this document on their website.

1. The purpose of this standard is to bring about an improvement in the construction of the fronts of vehicles and, in particular, those areas which have been most frequently identified as causing injury when in collision with a pedestrian or other vulnerable road user. The tests required are limited to those elements of the child and adult body most frequently identified as sustaining injury, i.e. the adult head and leg and the child head. To achieve the required improvements in construction of vehicles, the tests are based on sub-system component impactors representing those body regions and impacted at speeds representative of that below which the majority of injuries occur.
2. The vehicles to be tested under the standard are representative of the majority of vehicles in circulation in the urban environment, where there is a greater potential for collision with pedestrians and other vulnerable road users, and include passenger cars, and light trucks.
3. Europe in 2003 had taken up 2 phase implementations of the pedestrian protection test standard. The intended phase 2 will now be GTR 9 requirements.
4. AIS-100 was discussed in AISC 30 and it was agreed to align the technical requirements in line with GTR 9 but scope to be aligned with 2003/102/EEC phase 1 for the following two reasons –
 - * this is the first step into pedestrian protection requirements to understand the design, development, testing and certification modalities. India does not have any previous experience with these requirements.
 - * the other category vehicles would face operational difficulties if made to comply with GTR.

5. The scope of AIS-100 was discussed again in AISC 33 during Oct 09. Based on WP29 document ECE/TRANS/WP.29/GRSP/20, the FFV exemptions are extended to all M1 categories.
6. Aligned AIS-100 (Rev. 1) with UN GTR No.9 Amd.2 was discussed in the 9th AISC Crash Panel meeting held on June 10, 2021.

UN GTR No.9 Amd.2 introduced the flexible pedestrian legform impactor (FlexPLI) as a single harmonized test tool aimed at enhancing the level of protection for the lower legs of pedestrians.

FlexPLI shows superior biofidelity at component and assembly level using both the testing and the simulation tools. The improvements in the knee and tibia area were presented. A comparison study of the FlexPLI and post-mortem human subject (PMHS) test data was done for the performance limits. The FlexPLI was shown as more human-like with regard to the injury mechanism of the tibia.

While preparing this standard considerable assistance is derived from the following international standards:

UN Global Technical Regulation No. 9, Amendment 2	Pedestrian Safety
UN Regulation No 127	Uniform provisions concerning the approval of motor vehicles with regard to their pedestrian safety performance

The AISC panel and the Automotive Industry Standard Committee (AISC) responsible for preparation of this standard is given in Annex C and Annex D respectively.

Requirements for the Protection of Pedestrian and other Vulnerable Road Users in the event of a Collision with a Motor Vehicle		
Clause / Annex No.	Contents	Page No.
1	Scope	1/52
2	References	1/52
3	Definitions	1/52
4	General Requirements	15/52
5	Performance Requirements	15/52
6	Test Specifications	17/52
7	Test Procedures	28/52
8	Certification of Impactors	32/52
9	Application for Approval	46/52
10	Approval	47/52
11	Modifications and Extension of Approval of the Vehicle Type	47/52
12	Criteria for Selection of Worst Case and Extension of Approvals	47/52
Annexes		
Annex A	Information to be Provided with Application for Type Approval of a Vehicle with Respect to Pedestrian Protection	48/52
Annex B	Guidelines for Selection of Pedestrian Impactor Tests for Change in the Vehicle Type	49/52
Annex C	Composition of AISC panel on Pedestrian Protection	50/52
Annex D	AISC Committee composition	52/52

Requirements for the Protection of Pedestrian and other Vulnerable Road Users in the event of Collision with a Motor Vehicle

1. SCOPE

- 1.1 This standard applies to the frontal surfaces of the power-driven vehicles of:
 - 1.1.1 Category M1 and Category M2 with GVW not exceeding 4500 kg;
 - 1.1.2 Category N1 (derived from the vehicle categories M1 and M2 with GVW not exceeding 4500 kg).
- 1.2 The following vehicles are exempted from the scope of the standard:
 - 1.2.1 vehicle of categories mentioned in 1.1 with GVW upto 500 kg;
 - 1.2.2 vehicles of categories mentioned in 1.1 where the distance, measured longitudinally on a horizontal plane, between the transverse centerline of the front axle and the R point of the driver's seat is less than 1100 mm.

2. REFERENCES

- 2.1 The following standards are necessary adjuncts to this standard
 - 2.1.1 ISO 6487 : 2000 & ISO 6487 : 2002 Measurement Techniques in Impact Tests – Instrumentation
 - 2.1.2 ISO 3784 : 1976 Road vehicles - Measurement of Impact Velocity in Collision Tests
 - 2.1.3 AIS-053 / IS:14272 Automotive Vehicles - Types - Terminology
 - 2.1.4 ISO 2416 : 1992 Passenger Cars – Mass distribution

3. DEFINITIONS

When performing measurements as described in this standard, the vehicle should be positioned in its normal ride attitude.

If the vehicle is fitted with a badge, mascot or other structure, which would bend back or retract under an applied load of maximum 100 N, then this load shall be applied before and/or while these measurements are taken.

Any vehicle component which could change shape or position, other than suspension components or active devices to protect pedestrians, shall be set to their stowed position.

For the purposes of this standard:

- 3.1 **“Adult headform test area”** is an area on the outer surfaces of the front structure. The area is bounded:
- (a) In the front, by a wrap around distance (WAD) of 1,700 or a line 82.5 mm rearward of the bonnet leading edge reference line, whichever is most rearward at a given lateral position;
 - (b) At the rear, by a WAD 2,100 or a line 82.5 mm forward of the bonnet rear reference line, whichever is most forward at a given lateral position, and
 - (c) At each side, by a line 82.5 mm inside the side reference line.

The distance of 82.5 mm is to be set with a flexible tape held tautly along the outer surface of the vehicle.

- 3.2 **"Assessment Interval (AI)"** of the Flexible Pedestrian Lower legform Impactor is defined and limited by the time of first contact of the flexible lower legform impactor with the vehicle and the timing of the last zero crossing of all femur and tibia segments after their first local maximum subsequent to any marginal value of 15 Nm, within their particular common zero crossing phases. The AI is identical for all bone segments and knee ligaments. In case of any bone segment not having a zero crossing during the common zero crossing phases, the time history curves for all bone segments are shifted downwards until all bending moments are crossing zero. The downwards shift is to be applied for the determination of the AI only.
- 3.3 **"A-pillar"** means the foremost and outermost roof support extending from the chassis to the roof of the vehicle.
- 3.4 **"Bonnet leading edge"** means the edge of the front upper outer structure of the vehicle, including the bonnet & wings, the upper and side members of the headlight surrounds and any other attachments. The reference line identifying the position of the bonnet leading edge is defined by its height above the ground reference plane and by horizontal distance separating it from the bumper (bumper lead).
- 3.5 **"Bonnet leading edge height"** means, at any point on the bonnet leading edge, the vertical distance between the ground reference plane and bonnet leading edge reference line at that point.
- 3.6 **"Bonnet leading edge reference line"** means the geometric trace of the points of contact between a straight edge 1,000 mm long and the front surface of the bonnet, when the straight edge, held parallel to the vertical longitudinal plane of the car and inclined rearwards by 50° from the vertical and with the lower end 600 mm above the ground, is traversed across and in contact with the bonnet leading edge (see Figure 1).

For vehicles having the bonnet top surface inclined at 50°, so that the straight edge makes a continuous contact or multiple contacts rather than a point contact, determine the reference line with the straight edge inclined rearwards at an angle of 40° from the vertical.

For vehicles of such shape that the bottom end of the straight edge makes first contact with the vehicle then that contact is taken to be the bonnet leading edge reference line, at that lateral position.

For vehicles of such shape that the top end of the straight edge makes first contact with the vehicle then the geometric trace of 1,000 mm wrap around distance, will be used as bonnet leading edge reference line at that lateral position.

The top edge of the bumper shall also be regarded as the bonnet leading edge if it is contacted by the straight edge during this procedure.

- 3.7 **"Bonnet rear reference line"** means the geometric trace of the most rearward points of contact between a 165 mm diameter sphere and the front structure of the vehicle when the sphere is traversed across the front structure of the vehicle while maintaining contact with the windscreen (see Figure 2). The wiper blades and arms are removed during this process.

Where the bonnet rear reference line and the side reference line do not intersect, the bonnet rear reference line should be extended and/or modified using a semi-circular template, of radius 100 mm. The template should be made of a thin flexible sheet material that easily bends to a single curvature in any direction. The template should, preferably, resist double or complex curvature where this could result in wrinkling. The recommended material is a foam backed thin plastic sheet to allow the template to "grip" the surface of the vehicle. The template should be marked up with four points "A" through "D", as shown in Figure 3, while the template is on a flat surface.

The template should be placed on the vehicle with Corners "A" and "B" coincident with the side reference line. Ensuring these two corners remain coincident with the side reference line, the template should be slid progressively rearwards until the arc of the template makes first contact with the bonnet rear reference line. Throughout the process, the template should be curved to follow, as closely as possible, the outer contour of the vehicle's bonnet top, without wrinkling or folding of the template. If the contact between the template and bonnet rear reference line is tangential and the point of tangency lies outside the arc scribed by points "C" and "D", then the bonnet rear reference line is extended and/or modified to follow the circumferential arc of the template to meet the bonnet side reference line, as shown in Figure 4.

If the template cannot make simultaneous contact with the bonnet side reference line at points "A" and "B" and tangentially with the bonnet rear reference line, or the point at which the bonnet rear reference line and template touch lies within the arc scribed by points "C" and "D", then additional templates should be used where the radii are increased progressively in increments of 20 mm, until all the above criteria are met.

- 3.8 **"Bonnet top"** is the area which is bounded by (a), (b) and (c) as follows:
- (a) the bonnet leading edge reference line;
 - (b) the bonnet rear reference line;
 - (c) the side reference lines.
- 3.9 **"Bonnet top test area"** is composed of the adult headform test area and the child headform test area as defined in paragraphs 3.1. and 3.15. respectively.
- 3.10 **"Bumper"** means the front, lower, outer structure of a vehicle. It includes all structures that are intended to give protection to a vehicle when involved in a low speed frontal collision and also any attachments to this structure. The reference height and lateral limits of the bumper are identified by the corners and the bumper reference lines.
- 3.11 **"Bumper beam"** means the structural cross member, rearward of the bumper fascia if present, protecting the front of the vehicle. The beam does not include foam, cover support or any pedestrian protection devices.
- 3.12 **"Bumper lead"** means for any longitudinal section of a vehicle, the horizontal distance in the vehicle longitudinal plane between the upper bumper reference line and the bonnet leading edge reference line.
- 3.13 **"Bumper test area"** means either the front vehicle fascia between the left and right corner of bumper as defined in paragraph 3.16., minus the areas covered by the distance of 42 mm inboard of each corner of bumper as measured horizontally and perpendicular to the longitudinal median plane of the vehicle, or between the outermost ends of the bumper beam as defined in paragraph 3.11. (see Figure 13), minus the areas covered by the distance of 42 mm inboard of each end of the bumper beam, as measured horizontally and perpendicular to the longitudinal median plane of the vehicle, whichever area is wider.
- 3.14 **"Centre of the knee"** of the lower legform impactor is defined as the point about which the knee effectively bends.
- 3.15 **"Child headform test area"** is an area on the outer surfaces of the front structure. The area is bounded:
- (a) In the front, by a WAD 1,000 or a line 82.5 mm rearward of the bonnet leading edge reference line, whichever is most rearward at a given lateral position,
 - (b) At the rear, by a WAD 1,700 or a line 82.5 mm forward of the bonnet rear reference line, whichever is most forward at a given lateral position, and
 - (c) At each side, by a line 82.5 mm inside the side reference line.

The distance of 82.5 mm is to be set with a flexible tape held tautly along the outer surface of the vehicle.

- 3.16 **"Corner of bumper"** means the transversal position of the vehicle's point of contact with a corner gauge as defined in Figure 11.

For determination of the corner of bumper, the front surface of the corner gauge is moved parallel to a vertical plane with an angle of 60° to the vertical longitudinal center plane of the vehicle (see Figure 5 and Figure 12) at any height of the center point of the corner gauge between:

- (a) Equal to and above the point found on the vertical line intersecting the lower bumper reference line at the assessment position in transversal direction or at 75 mm above the ground reference plane, whichever is higher.
- (b) Equal to and below the point found on the vertical line intersecting the upper bumper reference line at the assessment position in transversal direction or at 1,003 mm above the ground reference plane, whichever is lower.

For determination of the corner of bumper, the gauge is moved to contact the outer contour/front fascia of the vehicle touching at the vertical center line of the gauge. The horizontal center line of the gauge is kept parallel to the ground plane.

The corners of bumper on both sides are subsequently defined as the outermost points of contact of the gauge with the outer contour/front fascia of the vehicle as determined in accordance with this procedure. Any points of contact on the top and the bottom edges of the gauge are not taken into account. The external devices for indirect vision and the tyres shall not be considered.

- 3.17 **"Corner reference point"** means the intersection of the bonnet leading edge reference line and of the bonnet side reference line (see Figure 14).
- 3.18 **"Driver mass"** means the nominal mass of a driver that shall be 75 kg (subdivided into 68 kg occupant mass at the seat and 7 kg luggage mass in accordance with ISO standard 2416–1992).
- 3.19 **"Femur"** of the lower legform impactor is defined as all components or parts of components (including flesh, skin covering, damper, instrumentation and brackets, pulleys, etc. attached to the impactor for the purpose of launching it) above the level of the centre of the knee.
- 3.20 **"Front reference line for child headform"** means the geometric trace as described on the vehicle front structure using a WAD1000 line. In the case of vehicles where the wrap around distance to the bonnet leading edge reference line, is more than 1,000 mm at any point, then the bonnet leading edge reference line will be used as the front reference line for child headform at that point.
- 3.21 **"Front structure"** means all outer structures of the vehicle except the windscreen, the windscreen header, the A-pillars and structures rearward of these. It therefore includes, but is not limited to, the bumper, the bonnet, wings, scuttle, wiper spindles and lower windscreen frame.

- 3.22 **"Ground reference plane"** means a horizontal plane, either real or imaginary, that passes through the lowest points of contact for all tyres of a vehicle while the vehicle is in its normal ride attitude. If the vehicle is resting on the ground, then the ground level and the ground reference plane are one and the same. If the vehicle is raised off the ground such as to allow extra clearance below the bumper, then the ground reference plane is above ground level.
- 3.23 **"Head Injury Criterion (HIC)"** means the calculated result of accelerometer time histories using the following formula:

$$\text{HIC} = \left[\frac{1}{t_2 - t_1} \int_{t_1}^{t_2} a \, dt \right]^{2.5} (t_2 - t_1)$$

Where:

- a is the resultant acceleration measured in units of gravity "g" (1 g = 9.81 m/s²);
- t₁ are the two-time instants (expressed in seconds) during the impact, and defining an interval between the beginning and the end of the recording period for which the value of HIC is a maximum (t₂ - t₁ ≤ 15 ms)
- 3.24 **"Impact point"** means the point on the vehicle where initial contact by the test impactor occurs. The proximity of this point to the target point is dependent upon both the angle of travel by the test impactor and the contour of the vehicle surface (see point B in Figure 6).
- 3.25 **"Lower bumper height"** means the vertical distance between the ground reference plane and the lower bumper reference line, with the vehicle positioned in its normal ride attitude.
- 3.26 **"Lower bumper reference line"** means the lower limit to significant points of pedestrian contact with the bumper. It is defined as the geometric trace of the lowermost points of contact between a straight edge 700 mm long and the bumper, when the straight edge, held parallel to the vertical longitudinal plane of the car and inclined forwards by 25° from the vertical, is traversed across the front of the car, while maintaining contact with the ground and with the surface of the bumper (see Figure 7).
- 3.27 **"Mass in running order"** means the nominal mass of a vehicle as determined by the sum of unladen vehicle mass and driver's mass.
- 3.28 **"Measuring point"** may also be referred to as "test point". In all cases, the result of the test shall be attributed to this point, independent of where first contact occurs.

- 3.28.1 **"Measuring point"** for the headform test means a point on the vehicle's outer surface selected for assessment. The measuring point is where the headform's profile contacts the vehicle's outer surface cross section in a vertical longitudinal plane through the center of gravity of the headform.
- 3.28.2 **"Measuring point"** for the lower legform to bumper test and the upper legform to bumper test is located in the vertical longitudinal plane through the central axis of the impactor (see Figure 15).
- 3.29 **"Normal ride attitude"** means the vehicle positioned on a flat horizontal surface with the following configuration:
- Mass of the vehicle with bodywork and all factory fitted equipment, electrical and auxiliary equipment for normal operation of vehicle, including liquids, tools, fire extinguisher, standard spare parts, chocks and spare wheel, if fitted.
 - The fuel tank filled to at least 90 per cent of rated capacity and the other liquid containing systems (except those for used water) to 100 per cent of the capacity specified by the manufacturer.
 - the tyres inflated to manufacturer recommended pressures,
 - the front wheels in the straight-ahead position
 - with driver & a passenger masses of 75 kg (subdivided into 68 kg occupant mass at the seat and 7 kg luggage mass in accordance with ISO standard 2416–1992) positioned on the respective seats
 - The front seats placed at the nominal mid-track position.
 - The suspension set in normal running condition as specified by the manufacturer for a speed of 40 km/h.
- 3.30 **"Passenger mass"** means the nominal mass of a passenger that shall be 68 kg, with in addition a 7 kg provision for luggage which shall be located in the luggage compartment(s) in accordance with ISO standard 2416–1992.
- 3.31 **"Rear reference line for adult headform"** means a geometric trace as described on the front structure of the vehicle using a WAD2100 line.
- 3.32 **"Primary reference marks"** means holes, surfaces, marks and identification signs on the vehicle body. The type of reference mark used and the vertical (Z) position of each mark relative to the ground shall be specified by the vehicle manufacturer according to the running conditions specified in paragraph 3.27. These marks shall be selected so as to be able to easily check the vehicle front and rear ride heights and vehicle attitude.

The primary reference marks shall be within $\pm 25\text{mm}$ of the design position in the vertical (Z) axis. All tests are conducted with either the vehicle or all further measurements adjusted to simulate the vehicle being in the design position. This position shall be considered to be the normal ride attitude.

- 3.33 **"R point"** or **"Seating reference point"** means a design point defined by the vehicle manufacturer for each seating position & established with respect to the three-dimensional reference system.
- 3.34 **"Side reference line"** means the geometric trace of the highest points of contact between a straight edge 700 mm long and the sides of the vehicle, when the straight edge, held parallel to the transverse vertical plane of the vehicle and inclined inwards by 45°, is traversed down, and maintains contact with the sides of the front structure (see Figure 8).
- 3.35 **"Target point"** means the intersection of the projection of the headform longitudinal axis with the front surface of the vehicle (see point A in Figure 6).
- 3.36 **"Third of the bonnet leading edge"** means the geometric trace between the corner reference points, measured with a flexible tape following the outer contour of the leading edge, divided in three equal parts.
- 3.37 **"Third of the bonnet top"** means the geometric trace of the area between the bonnet side reference lines, measured with a flexible tape following the outer contour of the bonnet top on any transverse section, divided in three equal parts.
- 3.38 **"Third of the bumper"** means the geometric trace between the corners of the bumper, measured with a flexible tape following the outer contour of the bumper, divided in three equal parts.
- 3.39 **"Tibia"** of the lower legform impactor is defined as all components or parts of components (including flesh, skin covering, instrumentation and brackets, pulleys, etc. attached to the impactor for the purpose of launching it) below the level of the centre of the knee. Note that the tibia as defined includes allowances for the mass, etc., of the foot.
- 3.40 **"Unladen vehicle mass"** means the nominal mass of a complete vehicle as determined by the following criteria:
- (a) Mass of the vehicle with bodywork and all factory fitted equipment, electrical and auxiliary equipment for normal operation of vehicle, including liquids, tools, fire extinguisher, standard spare parts, chocks and spare wheel, if fitted.
 - (b) The fuel tank shall be filled to at least 90 per cent of rated capacity and the other liquid containing systems (except those for used water) to 100 per cent of the capacity specified by the manufacturer.
- 3.41 **"Upper bumper reference line"** means the upper limit to significant points of pedestrian contact with the bumper. For vehicles with an identifiable bumper structure it is defined as the geometric trace of the uppermost points of contact between a straight edge and the bumper, when the straight edge, held parallel to the vertical longitudinal plane of the car and inclined rearwards by 20° to the vertical, is traversed across the front of the car, while maintaining contact with the surface of the bumper (see Figure 9).

Where necessary the straight edge shall be shortened to avoid any contact with structures above the bumper.

3.42 **"Vehicle type"** means a category of vehicles which, forward of the A-pillars, do not differ in such essential respects as:

- (a) the structure
- (b) the main dimensions
- (c) the materials of the outer surfaces of the vehicle
- (d) the component arrangement (external or internal)

insofar as they may be considered to have a negative effect on the results of the impact tests prescribed in this standard;

3.43 **"Vehicles of category M₁ derived from N₁"** means those vehicles of M₁ category which, forward of the A-pillars, have the same general structure and shape as a pre-existing N₁ category vehicle.

3.44 **"Vehicles of category N₁ derived from M₁"** means those vehicles of N₁ category, forward of the A-pillar, have the same general structure and shape as a pre-existing M₁ category vehicle.

3.45 **"Wrap Around Distance (WAD)"** means the geometric trace described on the outer surface of the vehicle front structure by one end of a flexible tape, when it is held in a vertical longitudinal plane of the vehicle and traversed across the front structure. The tape is held taut throughout the operation with one end held at the same level as the ground reference level, vertically below the front face of the bumper and the other end held in contact with the front structure (see Figure 10). The vehicle is positioned in the normal ride attitude.

This procedure shall be followed, using alternative tapes of appropriate lengths, to describe wrap around distances of 1,000 mm (WAD1000), of 1,700 mm (WAD1700) and of 2,100 mm (WAD2100).

3.46 **"Windscreen"** means the frontal glazing of the vehicle situated between the A-pillars.

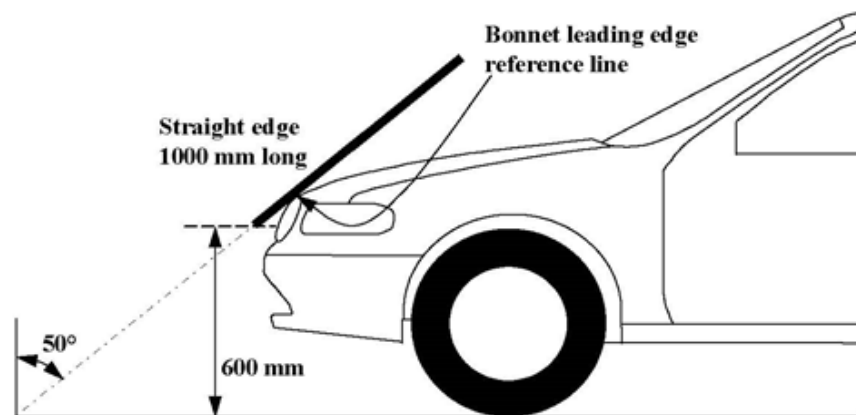

Figure 1
Bonnet Leading Edge Reference Line

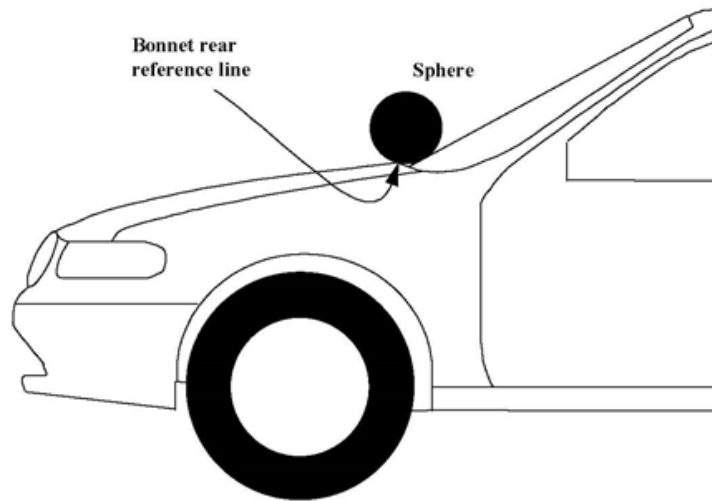

Figure 2
Bonnet Rear Reference Line

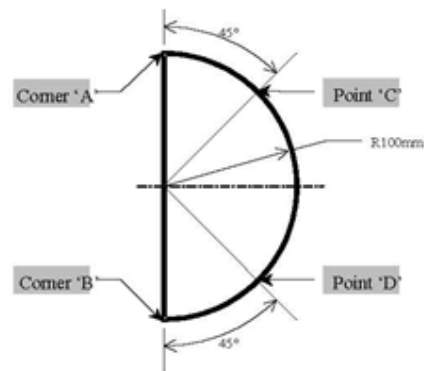

Figure 3
Template

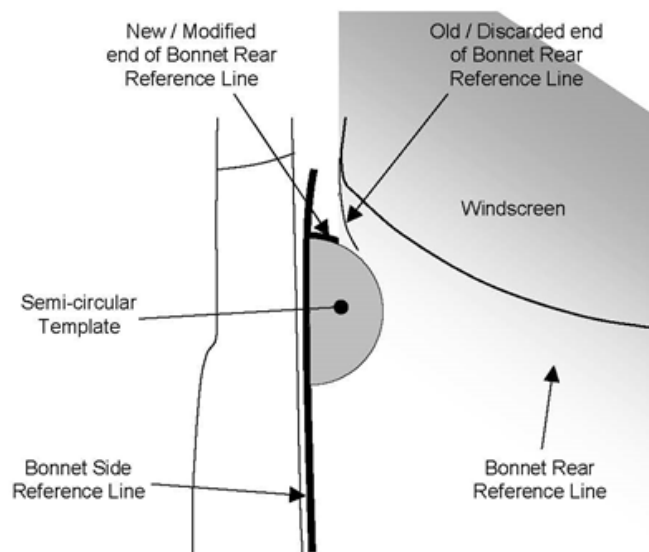

Figure 4
Marking of Intersection between Bonnet Rear and Side Reference Lines

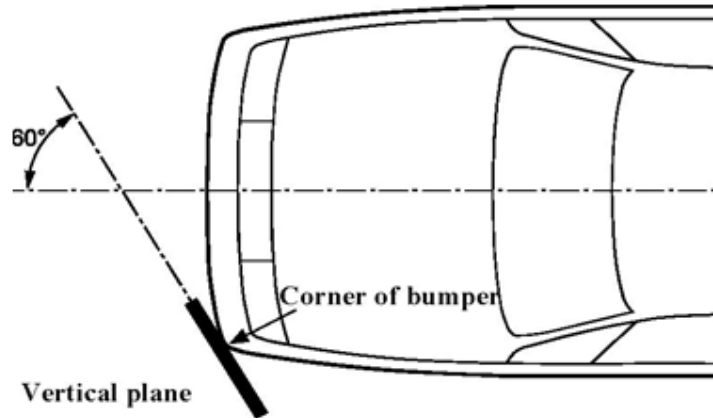

Figure 5
Corner of Bumper

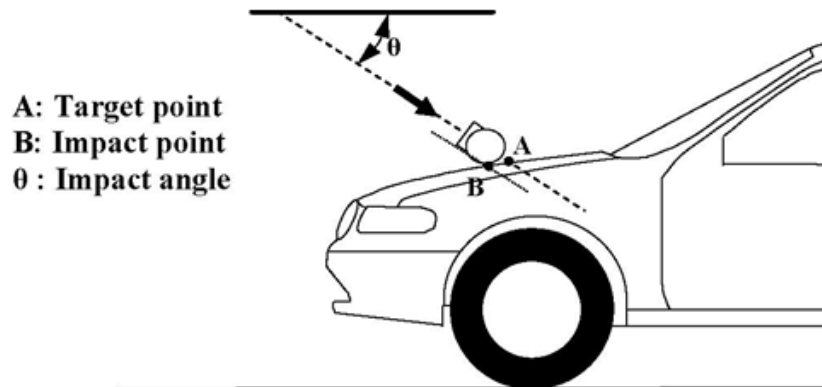

Figure 6
Impact and Target Point

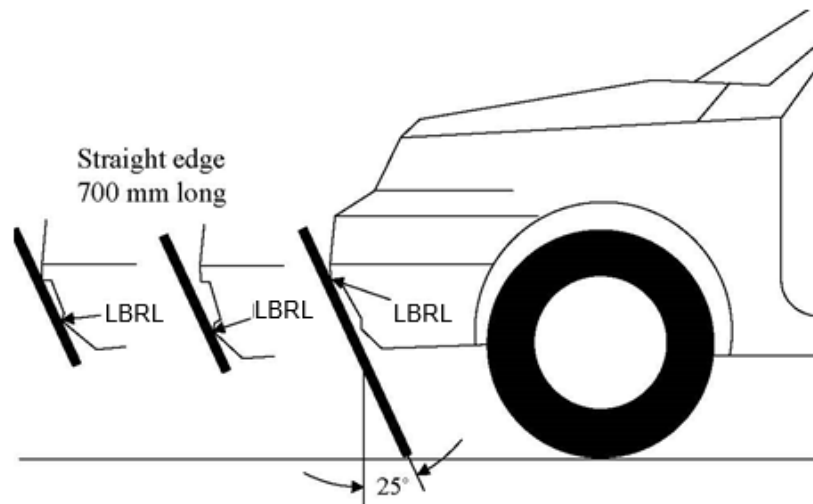

Figure 7
Lower Bumper Reference Line

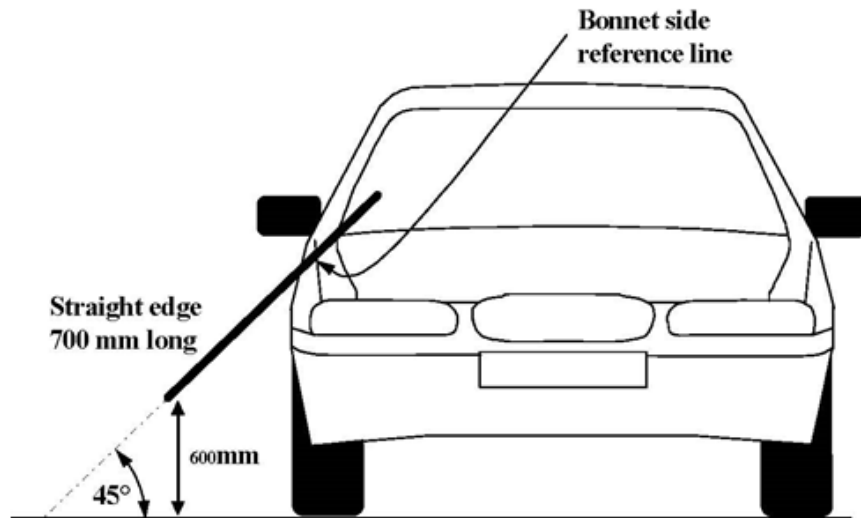

Figure 8
Side Reference Line

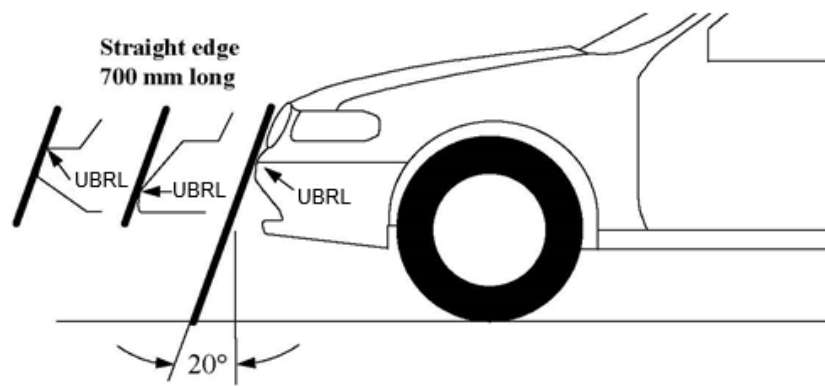

Figure 9
Upper Bumper Reference Line

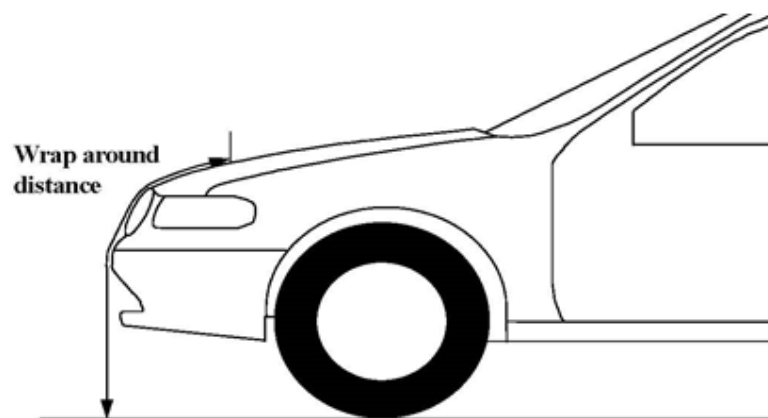
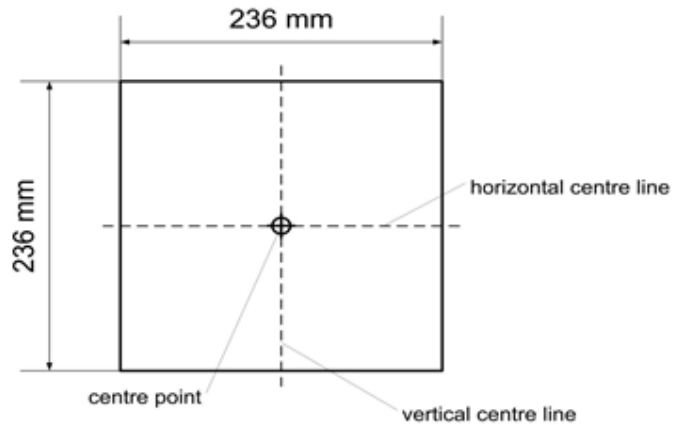

Figure 10
Wrap around Distance Measurement



The front surface of the corner gauge is flat.

The center point is the intersection of the vertical and horizontal center lines on the front surface.

Figure 11
Corner gauge

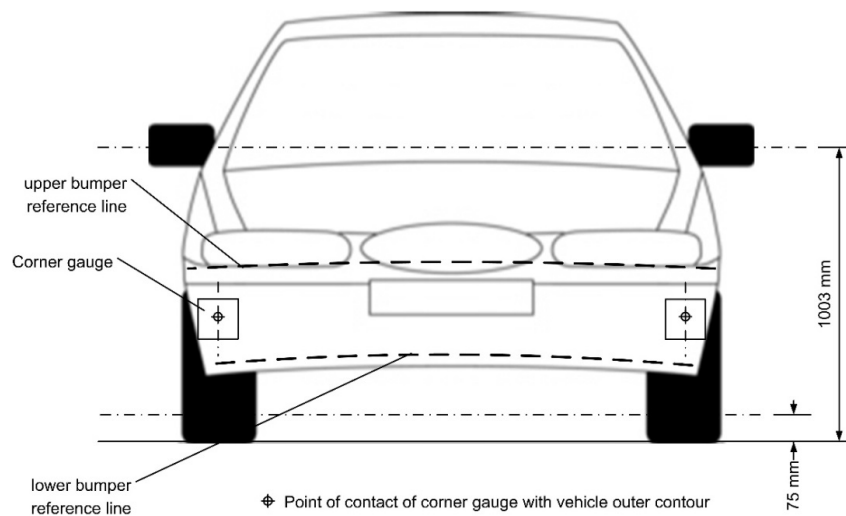

Note: The corner gauges are to be moved in vertical and horizontal directions to enable contact with the outer contour/front fascia of the vehicle

Figure 12
Determination of the corner of bumper with the corner gauge for Flexible Pedestrian Lower legform Impactor (shown in random location)

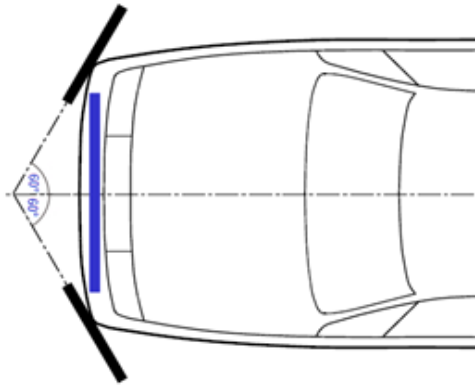

Figure 13

Determination of bumper test area (note that the corner gauges are to be moved in vertical and horizontal directions to enable contact with the outer contour/front fascia of the vehicle)

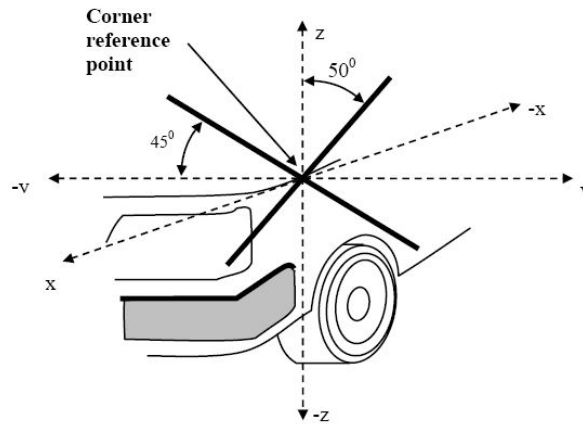

Figure 14

Determination of corner reference point; intersection of the bonnet leading edge reference line and the bonnet side reference line

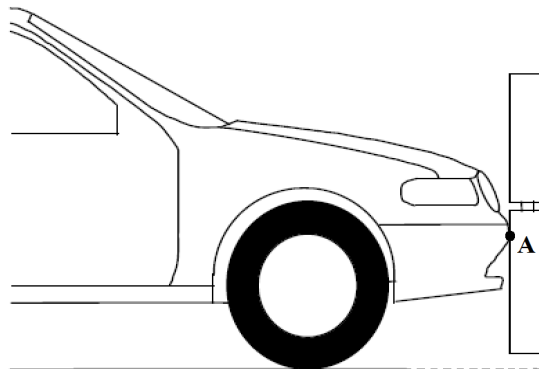

Figure 15

Measuring point in the vertical longitudinal plane through the central axis of the legform impactor (see paragraph 3.28.2)

4. GENERAL REQUIREMENTS

4.1 Legform test to bumper:

For vehicles with a lower bumper height of less than 425 mm the requirements of paragraph 4.1.1 shall be applied.

For vehicles with a lower bumper height which is greater than, or equal to 425 mm and less than 500 mm the requirements of either paragraph 4.1.1 or 4.1.2, at the choice of the manufacturer, shall be applied.

For vehicles with a lower bumper height of greater than, or equal to, 500 mm the requirements of paragraph 4.1.2 shall be applied.

4.1.1 Flexible lower legform to bumper:

To verify compliance with the performance requirements as specified in paragraph 5.1.1, both the test impactor specified in paragraph 6.3.1 and the test procedures specified in paragraph 7.1 shall be used.

4.1.2 Upper legform to bumper:

To verify compliance with the performance requirements as specified in paragraph 5.1.2, both the test impactor specified in paragraph 6.3.2 and the test procedures specified in paragraph 7.2 shall be used.

4.2 Child headform impact:

To verify compliance with the performance requirements as specified in paragraph 5.2.1, both the test impactor specified in paragraph 6.3.3.1 and the test procedures specified in paragraph 7.3.4 shall be used.

4.3 Adult headform impact:

To verify compliance with the performance requirements as specified in paragraph 5.2.2, both the test impactor specified in paragraph 6.3.3.2 and the test procedures specified in paragraph 7.3.5 shall be used.

5. PERFORMANCE REQUIREMENTS

5.1 Legform to bumper:

- 5.1.1 When tested in accordance with paragraph 7.1 (Flexible lower legform impactor), the absolute value of the maximum dynamic medial collateral ligament elongation at the knee shall not exceed 22 mm, and the maximum dynamic anterior cruciate ligament and posterior cruciate ligament elongation shall not exceed 13 mm. The absolute value of dynamic bending moments at the tibia shall not exceed 340 Nm. In addition, the manufacturer may nominate bumper test widths up to a maximum of 264 mm in total where the absolute value of the tibia bending moment shall not exceed 380 Nm.

5.1.2 When tested in accordance with paragraph 7.2, the instantaneous sum of the impact forces with respect to time shall not exceed 7.5 kN and the bending moment on the test impactor shall not exceed 510 Nm.

5.2 Headform tests

5.2.1 Child headform to front structure:

When tested in accordance with paragraph 7.3.4, the HIC shall comply with paragraph 5.2.3.

5.2.2 Adult headform to the front structure:

When tested in accordance with paragraph 7.3.5, the HIC shall comply with paragraph 5.2.3.

5.2.3 The HIC recorded shall not exceed 1,000 over a minimum of one half of the child headform test area and 1,000 over two third of the combined child and adult headform test areas. The HIC for the remaining areas shall not exceed 1,700 for both head forms.

In case there is only a child headform test area, the HIC recorded shall not exceed 1,000 over two third of the test area. For the remaining area the HIC shall not exceed 1,700.

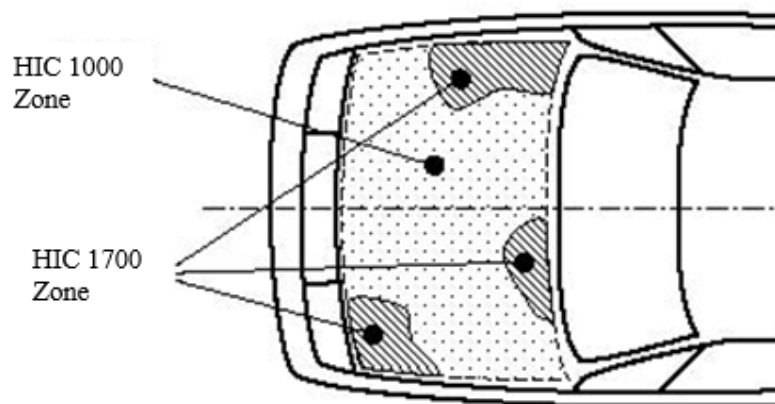

Figure 16

Example of Marking of HIC 1000 Zone & HIC 1700 Zone

5.2.4 Splitting of headform test zone:

5.2.4.1 The manufacturer shall identify the zones of the bonnet top where the HIC must not exceed 1,000 (HIC1000 Zone) & 1,700 (HIC1700 Zone) respectively (see Figure 16).

5.2.4.2 Marking of the "bonnet top" impact area as well as "HIC1000 Zone" and "HIC1700 Zone" will be based on a drawing supplied by the manufacturer, when viewed from a horizontal plane above the vehicle that is parallel to the vehicle horizontal zero plane. A sufficient number of x and y co-ordinates shall be supplied by the manufacturer to mark up the areas on the actual vehicle while considering the vehicle outer contour in the z direction.

- 5.2.4.3 The areas of "HIC1000 Zone" and "HIC1700 Zone" may consist of several parts, with the number of these parts not being limited. The determination of the impacted zone is done by the measuring point of the headform with the "bonnet top".
- 5.2.4.4 The calculation of the surface of the impact area as well as the surface areas of "HIC1000 Zone" and "HIC1700 Zone" shall be done on the basis of a projected bonnet when viewed from a horizontal plane parallel to the horizontal zero plane above the vehicle, on the basis of the drawing data supplied by the manufacturer.

6. TEST SPECIFICATIONS

6.1 General test conditions

6.1.1 Temperature and humidity

At the time of testing, the test facility and the vehicle or sub-system shall have a relative humidity of 40 per cent \pm 30 per cent and stabilized temperature of 20 ± 4 °C.

6.1.2 Impact test site

The test site shall consist of a flat, smooth and hard surface with a slope not exceeding 1 per cent.

6.2 Preparation of the vehicle

6.2.1 Either a complete vehicle, or a cut-body, adjusted to the following conditions shall be used for the test.

6.2.1.1 The vehicle shall be in its normal ride attitude, and shall be either securely mounted on raised supports or at rest on a flat horizontal surface with the parking brake applied.

6.2.1.2 The cut-body shall include, in the test, all parts of the vehicle front structure, all under-bonnet components and all components behind the windscreen that may be involved in a frontal impact with a vulnerable road user, to demonstrate the performance and interactions of all the contributory vehicle components. The cut-body shall be securely mounted in the normal vehicle ride attitude.

6.2.2 All devices designed to protect vulnerable road users when impacted by the vehicle shall be correctly activated before and/or be active during the relevant test. It shall be the responsibility of the manufacturer to show that any devices will act as intended in a pedestrian impact.

6.2.3 For vehicle components which could change shape or position, other than active devices to protect pedestrians, and which have more than one fixed shape or position shall require the vehicle to comply with the components in each fixed shape or position.

6.3 Test impactor specifications

6.3.1 Lower Legform impactor

6.3.1.1 Lower legform impactor specification

6.3.1.1.1 The flexible lower legform impactor shall consist of flesh and skin, flexible long bone segments (representing femur and tibia), and a knee joint as shown in Figure 17. The assembled impactor shall have a total mass of $13.2 \text{ kg} \pm 0.4 \text{ kg}$. The dimensions of the fully assembled impactor shall be as defined in Figure 17. Brackets, pulleys, protectors, connection parts, etc. attached to the impactor for the purposes of launching and/or protection may extend beyond the dimensions and tolerances shown in Figure 17 and Figures 18 and 19.

6.3.1.1.2 The cross-sectional shape of the femur main body segments, the tibia main body segments and their impact faces shall be as defined in Figure 18a.

6.3.1.1.3 The cross-sectional shape of the knee joint and its impact face shall be as defined in Figure 18b.

6.3.1.1.4 The masses of the femur and the tibia without the flesh and skin, including the connection parts to the knee joint, shall be $2.46 \text{ kg} \pm 0.12 \text{ kg}$ and $2.64 \text{ kg} \pm 0.13 \text{ kg}$ respectively. The mass of the knee joint without the flesh and skin shall be $4.28 \text{ kg} \pm 0.21 \text{ kg}$. The assembled mass of the femur, the knee joint and the tibia without the flesh and skin shall be $9.38 \text{ kg} \pm 0.3 \text{ kg}$. The screws that attach femur and tibia to the knee are part of the knee assembly.

The centers of gravity of the femur and tibia without the flesh and skin, including the connection parts to the knee joint, shall be as defined in Figure 17. The center of gravity of the knee joint shall be as defined in Figure 17.

The moment of inertia of the femur and the tibia without the flesh and skin, including the connection parts inserted to the knee joint, about the X-axis through the respective center of gravity shall be $0.0339 \text{ kgm}^2 \pm 0.0016 \text{ kgm}^2$ and $0.0486 \text{ kgm}^2 \pm 0.0023 \text{ kgm}^2$ respectively. The moment of inertia of the knee joint about the X-axis through the respective center of gravity shall be $0.0180 \text{ kgm}^2 \pm 0.0009 \text{ kgm}^2$.

6.3.1.1.5 For each test, the impactor (femur, knee joint and tibia without flesh and skin) shall be covered by the flesh and skin composed of synthetic rubber sheets (R1, R2) and foamed neoprene sheets (N1F, N2F, N1T, N2T, N3) as shown in Figure 19. The size of the sheets shall be within the requirements described in Figure 19. The sheets are required to have compression characteristics as shown in Figure 20. The compression characteristics shall be checked using material from the same batch as the sheets used for the impactor flesh and skin.

6.3.1.1.6 All impactor components shall be stored for a sufficient period of time in a controlled storage area with a stabilized temperature of $20 \pm 4^{\circ}\text{C}$ prior to impactor removal for testing. After removal from the storage, the impactor shall not be subjected to conditions other than those in the test area as defined in Paragraph 6.1.1.

6.3.1.2 **Lower legform instrumentation**

6.3.1.2.1 Four transducers shall be installed in the tibia to measure bending moments at the locations within the tibia. Three transducers shall be installed in the femur to measure bending moments applied to the femur. The sensing locations of each of the transducers are as defined in Figure 21. The measurement axis of each transducer shall be the X-axis of the impactor.

6.3.1.2.2 Three transducers shall be installed in the knee joint to measure elongations of the Medial Collateral Ligament (MCL), Anterior Cruciate Ligament (ACL), and Posterior Cruciate Ligament (PCL). The measurement locations of each transducer are shown in Figure 21. The measurement locations shall be within ± 4 mm along the X-axis from the knee joint center.

6.3.1.2.3 The instrumentation response value Channel Frequency Class (CFC), as defined in ISO 6487:2002, shall be 180 for all transducers. The Channel Amplitude Class (CAC) response values, as defined in ISO 6487:2002, shall be 30 mm for the knee ligament elongations and 400 Nm for the tibia and femur bending moments. This does not require that the impactor itself be able to physically elongate or bend until these values.

6.3.1.2.4 The determination of all flexible lower legform impactor peak tibia bending moments and ligament elongations shall be limited to the assessment interval (AI) as defined in paragraph 3.2. of this standard.

6.3.1.3 **Lower legform certification**

6.3.1.3.1 The lower legform impactor shall meet the performance requirements specified in paragraph 8.1

6.3.1.3.2 The impactor shall be certified using two certification tests as follows: First, the certification shall be conducted according to the inverse certification (IC) test procedure prescribed in paragraph 8.1.3 of this annex before starting a vehicle test series. Second, after a maximum of 10 vehicle tests, certification should be conducted according to the pendulum certification (PC) test procedure prescribed in paragraph 8.1.2 of this annex. Ongoing certification testing then shall constitute the sequence IC – PC – PC – IC – PC – PC – etc. with a maximum of 10 tests between each certification.

In addition, the impactor shall be certified according to the procedures prescribed in paragraph 8.1.1 below at least once a year.

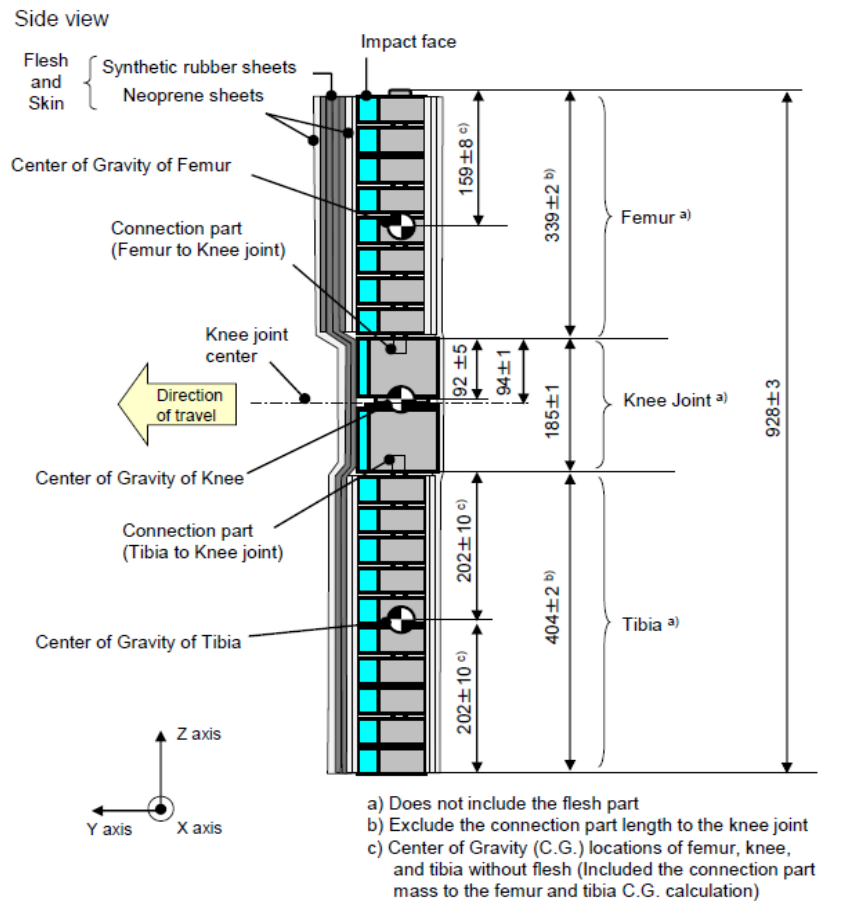

All dimensions in millimeters (mm)

Figure 17
 Flexible lower legform impactor Dimensions and center of gravity locations of femur, knee joint and tibia (side view)

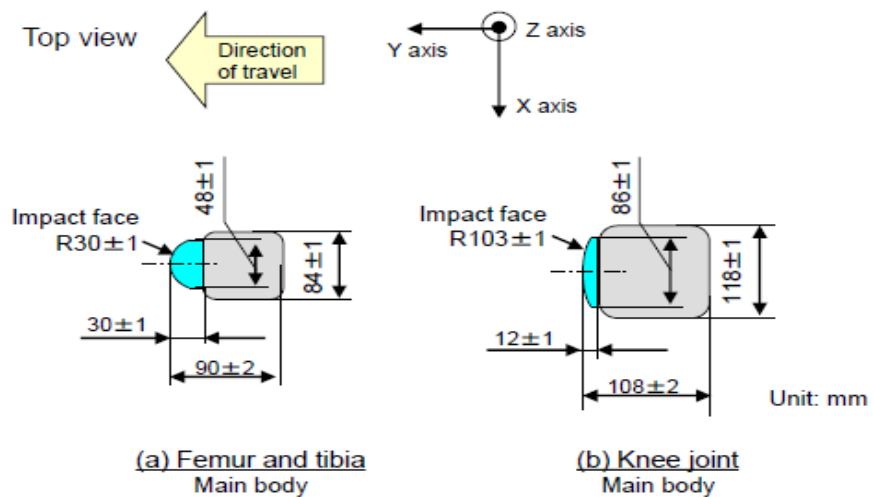

Figure 18
 Flexible lower legform impactor schematic plan views of femur, tibia, and knee dimensions

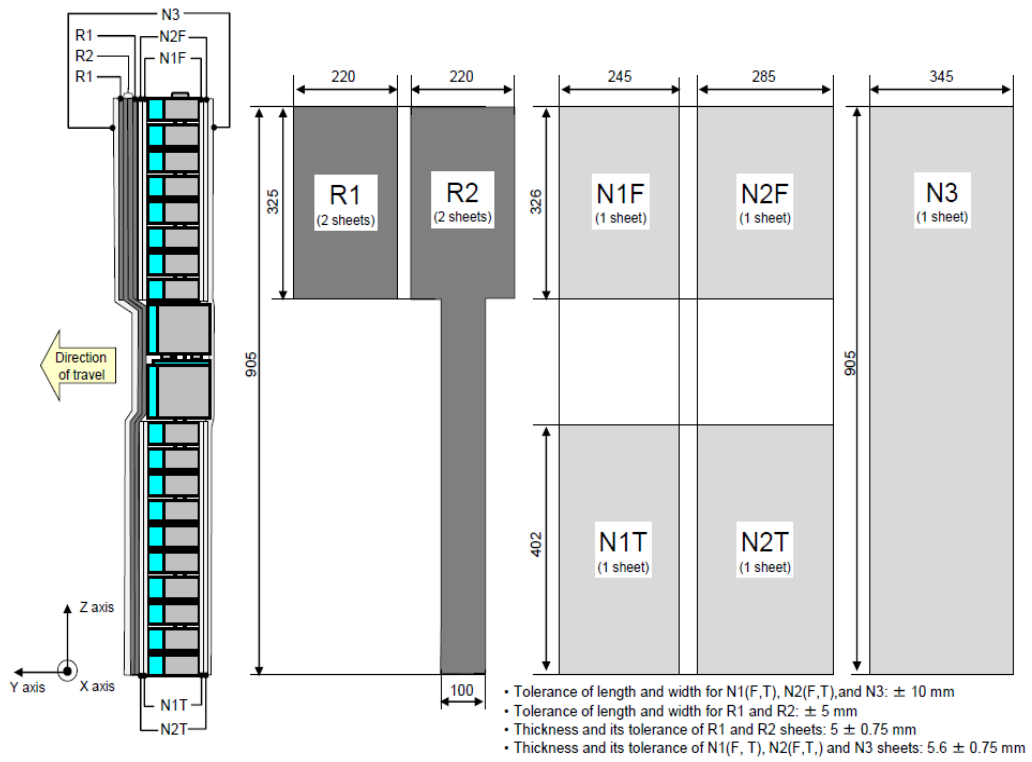
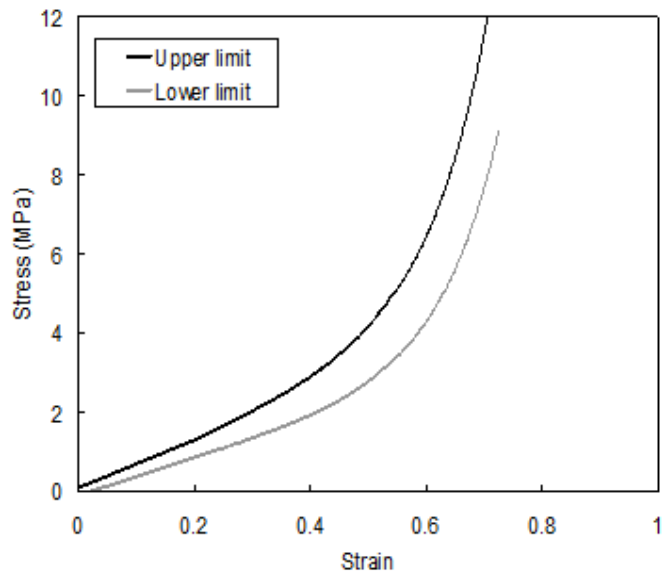
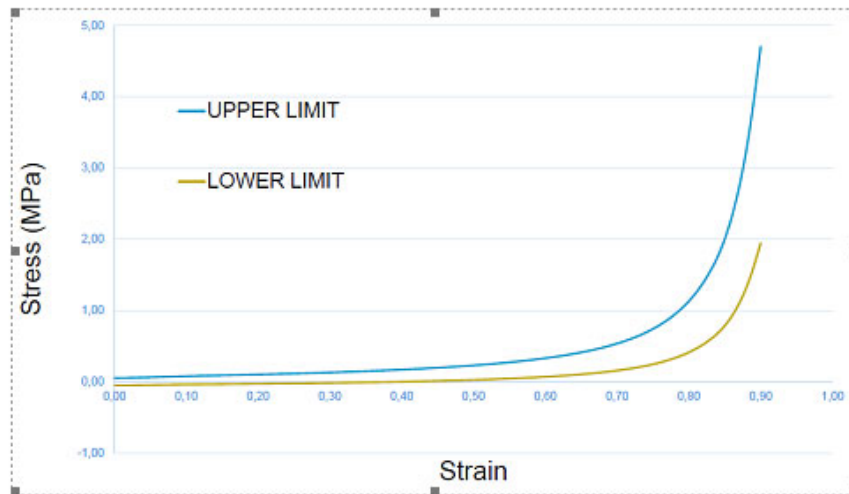

Figure 19
Flexible lower legform impactor: Flesh and skin dimensions



(a) Synthetic rubber sheets



(b) Neoprene sheets

Figure 20
Flexible lower legform impactor: Flesh and skin compression characteristics

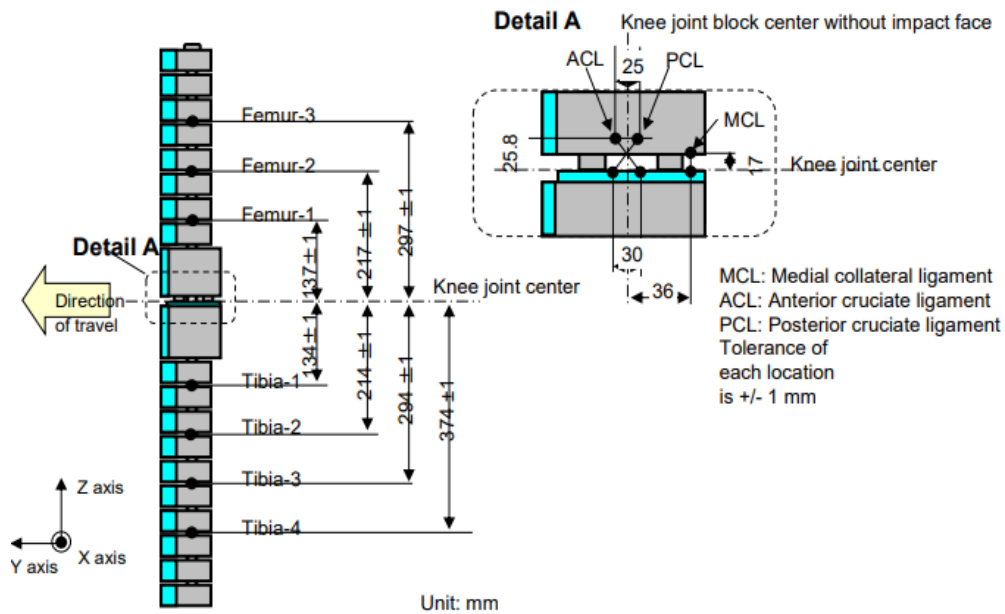

Figure 21
Flexible lower legform impactor instrument locations

6.3.2 **Upper legform impactor:**

6.3.2.1 **Upper legform impactor Specifications**

The upper legform impactor shall be rigid, foam covered at the impact side, and 350 ± 5 mm long (see Figure 22).

- 6.3.2.1.1 The total mass of the upper legform impactor including those propulsion and guidance components which are effectively part of the impactor during the impact shall be $9.5 \text{ kg} \pm 0.1 \text{ kg}$.

- 6.3.2.1.2 The total mass of the front member and other components in front of the load transducer assemblies, together with those parts of the load transducer assemblies in front of the active elements, but excluding the foam and skin, shall be 1.95 ± 0.05 kg.
- 6.3.2.1.3 The upper legform impactor for the bumper test shall be mounted to the propulsion system by a torque-limiting joint and be insensitive to off-axis loading. The impactor shall move only in the specified direction of impact when in contact with the vehicle and shall be prevented from motion in other directions including rotation about any axis.
- 6.3.2.1.4 The torque limiting joint shall be set so that the longitudinal axis of the front member is vertical at the time of impact with a tolerance of $\pm 2^\circ$, with the joint friction torque set to $675 \text{ Nm} \pm 25 \text{ Nm}$.
- 6.3.2.1.5 The centre of gravity of those parts of the impactor which are effectively forward of the torque limiting joint, including extra masses fitted, shall lie on the longitudinal centre line of the impactor, with a tolerance of ± 10 mm.
- 6.3.2.1.6 The length between the load transducer centre lines shall be 310 ± 1 mm and the front member diameter shall be 50 ± 1 mm.
- 6.3.2.1.7 For each test the foam flesh shall be two new sheets of 25 mm thick foam type CF-45 or equivalent, which shall be cut from the sheet of material used for the dynamic certification test. The skin shall be a 1.5 mm thick fiber reinforced rubber sheet. The mass of the foam and rubber skin together shall weigh 0.6 ± 0.1 kg (this excludes any reinforcement, mountings, etc. which are used to attach the rear edges of the rubber skin to the rear member). The foam and rubber skin shall be folded back towards the rear, with the rubber skin attached via spacers to the rear member so that the sides of the rubber skin are held parallel. The foam shall be of such a size and shape that an adequate gap is maintained between the foam and components behind the front member, to avoid significant load paths between the foam and these components.
- 6.3.2.1.8 The test impactor or at least the foam flesh shall be stored during a period of at least four hours in a controlled storage area with a stabilized humidity of 35 per cent ± 15 per cent and a stabilized temperature of $20 \pm 4^\circ\text{C}$ prior to impactor removal for test. After removal from the storage the impactor shall not be subjected to conditions other than those pertaining in the test area.
- 6.3.2.2 **Upper legform instrumentation**
- 6.3.2.2.1 The front member shall be strain gauged to measure bending moments in three positions, as shown in Figure 22, each using a separate channel. The strain gauges are located on the impactor on the back of the front member. The two outer strain gauges are located 50 ± 1 mm from the impactor's symmetrical axis. The middle strain gauge is located on the symmetrical axis with a ± 1 mm tolerance.

- 6.3.2.2.2 Two load transducers shall be fitted to measure individually the forces applied at either end of the upper legform impactor, plus strain gauges measuring bending moments at the centre of the upper legform impactor and at positions 50 mm either side of the centre line, (see Figure 22).
- 6.3.2.2.3 The instrumentation response value CFC, as defined in ISO 6487:2002, shall be 180 for all transducers. The CAC response values, as defined in ISO 6487:2002, shall be 10 kN for the force transducers and 1000 Nm for the bending moment measurements.
- 6.3.2.3 **Upper legform certification**
 - 6.3.2.3.1 The upper legform impactor shall meet the performance requirements specified in paragraph 8.2
 - 6.3.2.3.2 The certified impactor may be used for a maximum of 20 impacts before recertification (this limit does not apply to propulsion or guidance components). The impactor shall also be re-certified if more than one year has elapsed since the previous certification or if any impactor transducer output, in any impact, has exceeded the specified CAC.

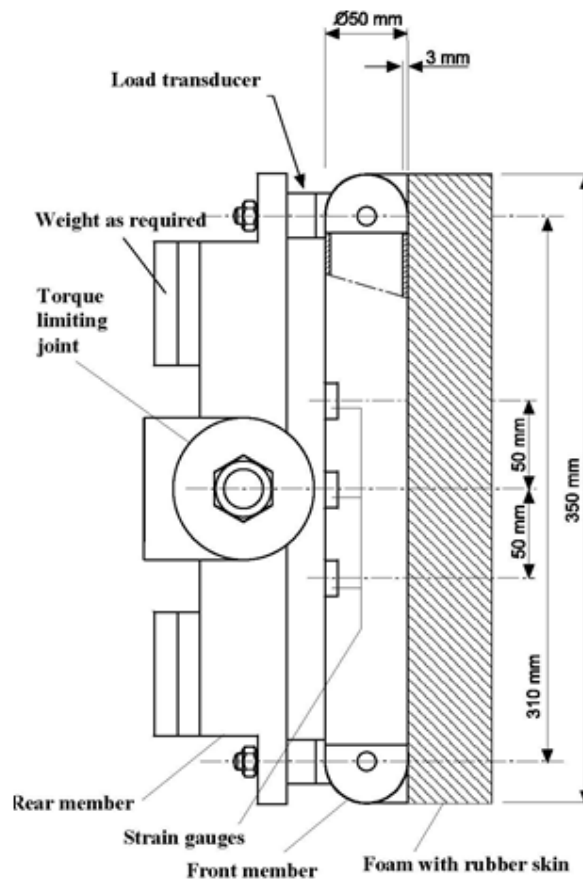

Figure 22
Upper Legform Impactor

6.3.3. **Child & Adult headform impactors:**

6.3.3.1 **Child headform impactor (see Figure 23)**

The child headform impactor shall be made of aluminium, be of homogenous construction and be of spherical shape. The overall diameter shall be 165 ± 1 mm as shown in Figure 23. The mass shall be 3.5 ± 0.07 kg. The moment of inertia about an axis through the centre of gravity and perpendicular to the direction of impact shall be within the range of 0.008 to 0.012 kgm^2 . The centre of gravity of the headform impactor including instrumentation shall be located in the geometric centre of the sphere with a tolerance of ± 2 mm.

The sphere shall be covered with a 14 ± 0.5 mm thick synthetic skin, which shall cover at least half of the sphere.

6.3.3.1.1 **Child headform instrumentation**

A recess in the sphere shall allow for mounting one triaxial or three uniaxial accelerometers within ± 10 mm seismic mass location tolerance from the centre of the sphere for the measurement axis, and ± 1 mm seismic mass location tolerance from the centre of the sphere for the perpendicular direction to the measurement axis.

If three uniaxial accelerometers are used, one of the accelerometers shall have its sensitive axis perpendicular to the mounting face A (see Figure 23) and its seismic mass shall be positioned within a cylindrical tolerance field of 1 mm radius and 20 mm length. The centre line of the tolerance field shall run perpendicular to the mounting face and its mid-point shall coincide with the centre of the sphere of the headform impactor.

The remaining accelerometers shall have their sensitive axes perpendicular to each other and parallel to the mounting face A and their seismic mass shall be positioned within a spherical tolerance field of 10 mm radius. The centre of the tolerance field shall coincide with the centre of the sphere of the headform impactor.

The instrumentation response value CFC, as defined in ISO 6487: 2002, shall be 1,000. The CAC response value, as defined in ISO 6487: 2002, shall be 500 g for the acceleration.

6.3.3.1.2 **First natural frequency**

The first natural frequency of the headform impactor shall be over 5,000 Hz.

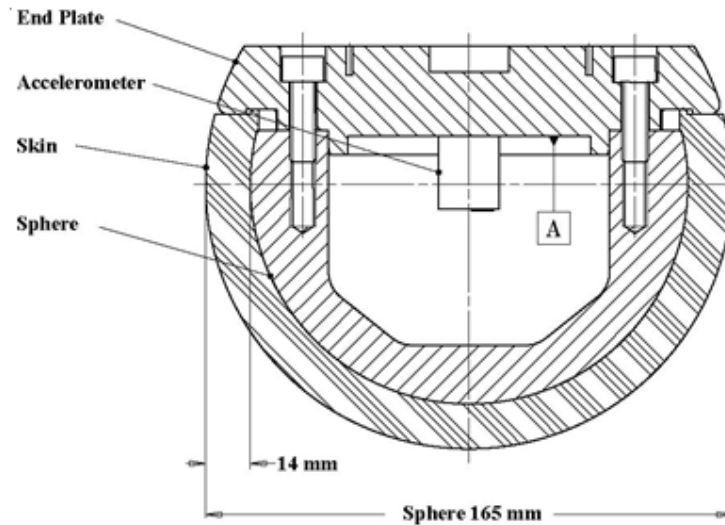

Figure 23
Child Headform Impactor

6.3.3.2 Adult headform impactor (see Figure 24)

The adult headform impactor shall be made of aluminium, be of homogenous construction and be of spherical shape. The overall diameter is 165 ± 1 mm as shown in Figure 24. The mass shall be 4.5 ± 0.1 kg. The moment of inertia about an axis through the centre of gravity and perpendicular to the direction of impact shall be within the range of 0.010 to 0.013 kgm^2 . The centre of gravity of the headform impactor including instrumentation shall be located in the geometric centre of the sphere with a tolerance of ± 5 mm.

The sphere shall be covered with a 14 ± 0.5 mm thick synthetic skin, which shall cover at least half of the sphere.

6.3.3.2.1 Adult headform instrumentation

A recess in the sphere shall allow for mounting one triaxial or three uniaxial accelerometers within ± 10 mm seismic mass location tolerance from the centre of the sphere for the measurement axis, and ± 1 mm seismic mass location tolerance from the centre of the sphere for the perpendicular direction to the measurement axis.

If three uniaxial accelerometers are used, one of the accelerometers shall have its sensitive axis perpendicular to the mounting face A (see Figure 24) and its seismic mass shall be positioned within a cylindrical tolerance field of 1 mm radius and 20 mm length.

The centre line of the tolerance field shall run perpendicular to the mounting face and its mid-point shall coincide with the centre of the sphere of the headform impactor.

The remaining accelerometers shall have their sensitive axes perpendicular to each other and parallel to the mounting face A and their seismic mass shall be positioned within a spherical tolerance field of 10 mm radius. The centre of the tolerance field shall coincide with the centre of the sphere of the headform impactor.

The instrumentation response value CFC, as defined in ISO 6487: 2002, shall be 1,000. The CAC response value, as defined in ISO 6487: 2002, shall be 500 g for the acceleration.

6.3.3.2.2 First natural frequency

The first natural frequency of the headform impactor shall be over 5,000 Hz.

6.3.3.3 Rear face of the headform impactors

A rear flat face shall be provided on the outer surface of the headform impactors which is perpendicular to the direction of travel, and typically perpendicular to the axis of one of the accelerometers as well as being a flat plate capable of providing for access to the accelerometers and an attachment point for the propulsion system.

6.3.3.4 Certification of the headform impactors

The headform impactors shall meet the performance requirements specified in paragraph 8.3. The certified impactors may be used for a maximum of 20 impacts before re-certification. The impactors shall be re-certified if more than one year has elapsed since the previous certification or if the transducer output, in any impact, has exceeded the specified CAC.

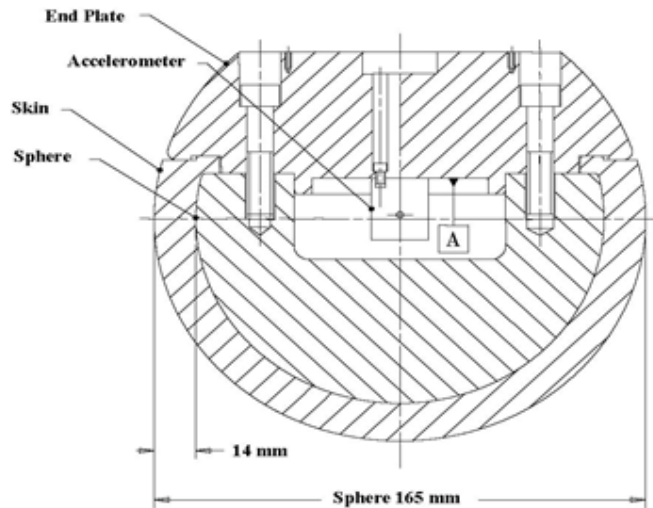

**Figure 24
Adult Headform Impactor**

7. TEST PROCEDURES

7.1 Legform to bumper test procedures:

7.1.1 Lower legform to bumper test procedure:

Each test shall be completed within two hours of when the impactor to be used is removed from the controlled storage area.

7.1.1.1 The selected measuring points shall be in the bumper test area as specified in 3.13.

7.1.1.2 A minimum of three lower legform to bumper tests shall be carried out, one each to the middle and the outer thirds of the bumper test area at positions judged to be the most likely to cause injury. Tests shall be to different types of structure, where they vary throughout the area to be assessed. The selected test points shall be a minimum of 84 mm apart as measured horizontally and perpendicular to the longitudinal median plane of the vehicle. The positions tested by the laboratories shall be indicated in the test report.

7.1.1.3 The direction of the impact velocity vector shall be in the horizontal plane and parallel to the longitudinal vertical plane of the vehicle. The tolerance for the direction of the velocity vector in the horizontal plane and in the longitudinal plane shall be $\pm 2^\circ$ at the time of first contact. The axis of the impactor shall be perpendicular to the horizontal plane, with a roll and pitch angle tolerance of $\pm 2^\circ$ in the lateral and longitudinal plane. The horizontal, longitudinal and lateral planes are orthogonal to each other (see Figure 25).

7.1.1.4 The bottom of the impactor (without parts needed for the purposes of launching and/or protection) shall be 75mm above the ground reference plane at the time of the first contact with the bumper (see Figure 26), with a tolerance of ± 10 mm. When setting the height of the propulsion system, an allowance shall be made for the influence of gravity during the period of free flight of the impactor.

7.1.1.5 The lower legform impactor for the bumper tests shall be in 'free flight' at the moment of impact. The impactor shall be released to free flight at such a distance from the vehicle that the test results are not influenced by contact of the impactor with the propulsion system during rebound of the impactor.

The impactor may be propelled by any means that can be shown to meet the requirements of the test.

7.1.1.6 At the time of first contact the impactor shall have the intended orientation about its vertical axis, for the correct operation of its knee joint, with a yaw angle tolerance of $\pm 5^\circ$ (see Figure 25).

7.1.1.7 At the time of first contact the centre line of the impactor shall be within a ± 10 mm tolerance to the selected impact location.

- 7.1.1.8 During contact between the impactor and the vehicle, the impactor shall not contact the ground or any object which is not part of the vehicle.
- 7.1.1.9 The impact velocity of the impactor when striking the bumper shall be 11.1 ± 0.2 m/s. The effect of gravity shall be taken into account when the impact velocity is obtained from measurements taken before the time of first contact.
- 7.1.1.10 The tibia bending moments shall not exceed ± 15 Nm within an evaluation interval of 30ms immediately prior to impact.
- 7.1.1.11 The offset compensation shall be done with the flexible lower legform impactor in resting position prior to the test / acceleration phase.

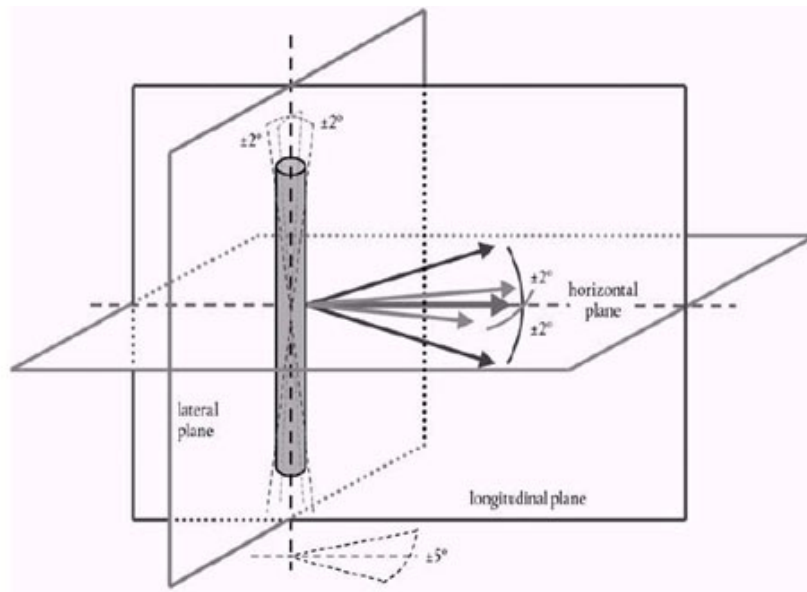

Figure 25
Tolerances of Angles for the Flexible Lower Legform Impactor at the time of the First Impact (see Paragraphs 7.1.1.3 and 7.1.1.6)

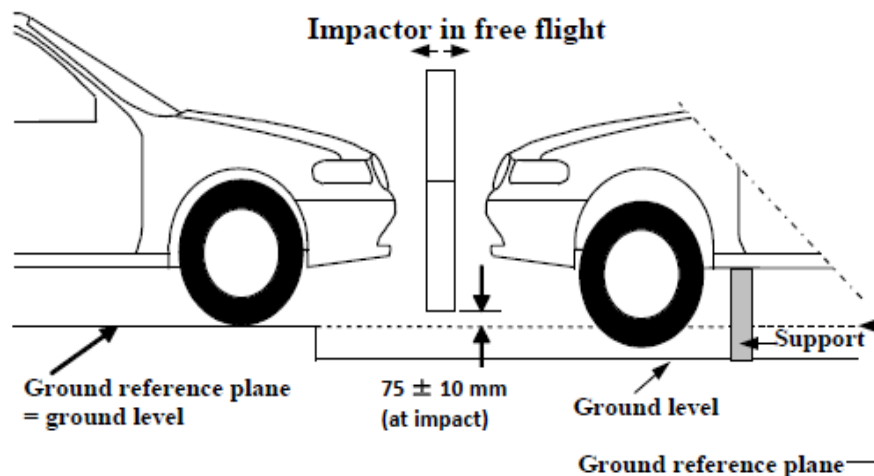

Figure 26
Lower Legform to Bumper Tests for Complete Vehicle in Normal Ride Attitude (Left) and for Cut-Body Mounted on Supports (Right)

7.2 Upper legform to bumper test procedure:

Each test shall be completed within two hours of when the impactor to be used is removed from the controlled storage area.

7.2.1 The selected measuring points shall be in the bumper test area as defined in paragraph 3.13

7.2.2 A minimum of 3 upper legform to bumper tests shall be carried out, one each to the middle and the outer thirds of the bumper at positions judged to be the most likely to cause injury. Tests shall be to different types of structure, where they vary throughout the area to be assessed. The selected measurement points shall be a minimum of 84 mm apart, and a minimum of 42 mm inside the defined corners of the bumper. These minimum distances are measured horizontally and perpendicular to the longitudinal median plane of the vehicle. The positions tested by the test agency shall be indicated in the test report.

7.2.3 The direction of impact shall be parallel to the longitudinal axis of the vehicle, with the axis of the upper legform vertical at the time of first contact. The tolerance to this direction is $\pm 2^\circ$.

At the time of first contact the impactor centre line shall be vertically midway between the upper bumper reference line and the lower bumper reference line with a ± 10 mm tolerance and the impactor vertical centre line shall be positioned laterally with the selected impact location with a tolerance of ± 10 mm.

7.2.4 The impact velocity of the upper legform impactor when striking the bumper shall be 11.1 ± 0.2 m/s.

7.3 Headform test procedures

7.3.1 Propulsion of the headform impactors

The headform impactors shall be in "free flight" at the moment of impact, at the required impact velocity (as specified in paragraphs 7.3.4.6 and 7.3.5.6) and the required direction of impact (as specified in paragraphs 7.3.4.7 and 7.3.5.7).

The impactors shall be released to "free flight" at such a distance from the vehicle that the test results are not influenced by contact of the impactor with the propulsion system during rebound of the impactor.

7.3.2 Measurement of impact velocity

The velocity of the headform impactor shall be measured at some point during the free flight before impact, in accordance with the method specified in ISO 3784:1976. The accuracy of velocity measurement shall be ± 0.01 m/sec. The measured velocity shall be adjusted considering all factors which may affect the impactor between the point of measurement and the point of impact, in order to determine the velocity of the impactor at the time of impact. The angle of the velocity vector at the time of impact shall be calculated or measured.

- 7.3.3 Recording
- The acceleration time histories shall be recorded, and HIC shall be calculated. The first point of contact on the front structure of the vehicle shall be recorded. Recording of test results shall be in accordance with ISO 6487:2002.
- 7.3.4 **Child headform test procedure**
- This test procedure is applicable with respect to the requirements of paragraphs 5.2.1. and 5.2.3.
- 7.3.4.1 Tests shall be made to the front structure within the boundaries as defined in paragraph 3.15. For tests on the rear area of the bonnet top, the headform impactor shall not contact the windscreen or A-pillar before impacting the bonnet top.
- 7.3.4.2 A minimum of nine tests shall be carried out with the child headform impactor, three tests each to the middle and the outer thirds of the child/small adult bonnet top test areas, at positions judged to be the most likely to cause injury. Tests shall be to different types of structure, where these vary throughout the area to be assessed and at positions judged to be the most likely to cause injury.
- 7.3.4.3 The selected measuring points for the child/small adult headform impactor shall be a minimum of 165 mm apart and within the child headform test area as defined in paragraph 3.15. of this standard.
- 7.3.4.4 No measuring point shall be located so that the impactor will impact the test area with a glancing blow or otherwise resulting in a more severe second impact outside the test area.
- 7.3.4.5 For the child head form testing, the point of first contact of the headform impactor shall be within a longitudinal and transversal impact tolerance of ± 10 mm to the selected impact point and shall lie within the test area defined in para 3.15. This tolerance is measured along the surface of the bonnet.
- 7.3.4.6 The headform velocity at the time of impact shall be 9.7 ± 0.2 m/s.
- 7.3.4.7 The direction of impact shall be in the longitudinal vertical plane of the vehicle to be tested at an angle of $50 \pm 2^\circ$ to the horizontal. The direction of impact of tests to the front structure shall be downward and rearward.
- 7.3.5 **Adult headform test procedure:** This test procedure is applicable with respect to the requirements of paragraphs 5.2.2. and 5.2.3
- 7.3.5.1 Tests shall be made to the front structure within the boundaries as defined in paragraph 3.1. For tests at the rear of the bonnet top, the headform impactor shall not contact the windscreen or A-pillar before impacting the bonnet top.

- 7.3.5.2 A minimum of nine tests shall be carried out with the Adult headform impactor, three tests each to the middle and the outer thirds of the adult bonnet top test areas, at positions judged to be the most likely to cause injury. Tests shall be to different types of structure, where these vary throughout the area to be assessed and at positions judged to be the most likely to cause injury.
- 7.3.5.3 The selected measuring points for the adult headform impactor shall be a minimum of 165 mm apart and within the Adult headform test area as defined in paragraph 3.1 of this standard.
- 7.3.5.4 No measuring point shall be located so that the impactor will impact the test area with a glancing blow or otherwise resulting in a more severe second impact outside the test area.
- 7.3.5.5 For the adult head form testing, the point of first contact of the headform impactor shall be within a longitudinal and transversal impact tolerance of ± 10 mm to the selected impact point and shall lie within the test area defined in para 3.1. This tolerance is measured along the surface of the bonnet.
- 7.3.5.6 The headform velocity at the time of impact shall be 9.7 ± 0.2 m/s.
- 7.3.5.7 The direction of impact shall be in the longitudinal vertical plane of the paragraph of the vehicle to be tested at an angle of $65^\circ \pm 2^\circ$ to the horizontal. The direction of impact of tests to the front structure shall be downward and rearward.

7.4 **Measurement of test points – Particular specifications**

Notwithstanding the provisions of paragraphs 7.3.4.2. and 7.3.5.2. above, if a number of test locations have been selected in order of potential to cause injury and the test area remaining is too small to select another test location while maintaining the minimum spacing between tests, then less than nine tests for each impactor may be performed. The locations tested by the laboratories shall be indicated in the test report. However, the technical services conducting the tests shall perform as many tests as necessary to guarantee the compliance of the vehicle with the head injury criteria (HIC) limit values of 1000 for the HIC1000 zone and 1700 for the HIC1700 zone, especially in the location near to the borders between the two types of zones.

8. **CERTIFICATION OF IMPACTORS**

The impactors that are used in the tests described in this standard are required to comply with the following performance requirements.

The requirements for the lower legform impactor are specified in paragraph 8.1., the upper legform impactor requirements are specified in paragraph 8.2. and the adult and child headform impactors requirements are specified in paragraph 8.3

8.1 Flexible Lower legform impactor certification:**8.1.1 Static certification tests**

8.1.1.1 The femur and the tibia of the flexible lower legform impactor shall meet the requirements specified in Paragraph 8.1.1.2. when tested according to Paragraph 8.1.1.4. The knee joint of the lower legform impactor shall meet the requirements specified in Paragraph 8.1.1.3. when tested according to Paragraph 8.1.1.5. The stabilized temperature of the impactor during the certification tests shall be $20^{\circ} \pm 2^{\circ}\text{C}$.

The CAC response values, as defined in ISO 6487:2002, shall be 30mm for the knee ligament elongations and 4kN for the applied external load. For these tests, low-pass filtering at an appropriate frequency is permitted to remove higher frequency noise without significantly affecting the measurement of the response of the impactor.

8.1.1.2 When the femur and the tibia of the impactor, without flesh and skin, are loaded in bending in accordance with Paragraph 8.1.1.4., the applied moment and the generated deflection at the center of the femur and the tibia (M_c and D_c) shall be within the corridors shown in Figure 27.

8.1.1.3 When the knee joint of the impactor, without flesh and skin, is loaded in bending in accordance with Paragraph 8.1.1.5., the MCL, ACL, and PCL elongations and applied bending moment or the force at the center of the knee joint (M_c or F_c) shall be within the corridors shown in Figure 28.

8.1.1.4 The edges of the femur and tibia, without flesh and skin, not bending parts, shall be mounted to the support rig firmly as shown in Figure 29 and Figure 30. The Y-axis of the impactor shall be parallel to the loading axis within $180 \pm 2^{\circ}$ tolerance. To obtain repeatable loading, low friction Polytetrafluoroethylene (PTFE) plastic pads are used under each support (see Figures 29 and 30).

The center of the loading force shall be applied at the center of the femur and the tibia within $\pm 2\text{mm}$ tolerance along the Z-axis. The force shall be increased so as to maintain a deflection rate between 10 and 100mm/minute until the bending moment at the center part (M_c) of the femur or tibia reaches 380Nm.

8.1.1.5 The ends of the knee joint, without flesh and skin, shall be mounted to the support rig firmly as shown in Figure 31. The Y-axis of the impactor shall be parallel to the loading axis within $\pm 2^{\circ}$ tolerance. To obtain repeatable loading, low friction Polytetrafluoroethylene (PTFE) plastic pads are used under each support (see Figure 31). To avoid impactor damage, a foamed neoprene sheet shall be set between the loading ram and the impactor face of the knee joint, which is described in Figure 31, shall be removed. The foamed neoprene sheet used in this test shall have compression characteristics as shown in Figure 20.

The center of the loading force shall be applied at the knee joint center within $\pm 2^\circ\text{mm}$ tolerance along the Z-axis (see Figure 31). The external load shall be increased so as to maintain a deflection rate between 10 and 100mm/minute until the bending moment at the center part of the knee joint (M_c) reaches 400Nm.

8.1.2 **Dynamic Certification tests (Pendulum test)**

8.1.2.1 The assembled flexible lower legform impactor shall meet the requirements according to Paragraph 8.1.2.3. when tested as specified in Paragraph 8.1.2.4.

8.1.2.2 Certification:

8.1.2.2.1 The test facility used for the certification test shall have a stabilized temperature of $20 \pm 2^\circ\text{C}$ during the test.

8.1.2.2.2 The temperature of the certification area shall be measured at the time of certification and recorded in a certification report.

8.1.2.3 Requirements

8.1.2.3.1 When the flexible lower legform impactor is used for a test according to Paragraph 8.1.2.4., the absolute value of the maximum bending moment of the tibia at

- (a) Tibia-1 shall be $235\text{Nm} \leq 272\text{Nm}$,
- (b) Tibia-2 shall be $187\text{Nm} \leq 219\text{Nm}$,
- (c) Tibia-3 shall be $139\text{Nm} \leq 166\text{Nm}$,
- (d) Tibia-4 shall be $90\text{Nm} \leq 111\text{Nm}$.

The absolute value of the maximum elongation of MCL shall be

- (a) MCL shall be $20.5 \leq 24.0\text{mm}$,
- (b) ACL shall be $8.0 \leq 10.5\text{mm}$,
- (c) PCL shall be $3.5 \leq 5.0\text{mm}$.

For all these values for the maximum bending moment and the maximum elongation, the readings used shall be from the initial impact timing to 200ms after the impact timing.

8.1.2.3.2 The instrumentation response value CFC, as defined in ISO 6487:2002, shall be 180 for all transducers. The CAC response values, as defined in ISO 6487:2002, shall be 30mm for the knee ligament elongations and 400Nm for the tibia bending moments. This does not require that the impactor itself is able to physically elongate or bend until these values.

8.1.2.4 Test procedure

8.1.2.4.1 The flexible lower legform impactor, including the flesh and skin, shall be suspended from the dynamic certification test rig $15 \pm 1^\circ$ upward from the horizontal as shown in Figure 32. The impactor shall be released from the suspended position and fall freely against the pin joint of the test rig as shown in Figure 32.

8.1.2.4.2 The knee joint center of the impactor shall be 30 ± 1 mm below the bottom line of the stopper bar, and the tibia impact face without the flesh and skin shall be located 13 ± 2 mm from the front upper edge of the stopper bar when the impactor is hanging freely as shown in Figure 32.

8.1.3 **Dynamic Certification Tests (Inverse Test)**

8.1.3.1 The assembled flexible lower legform impactor shall meet the requirements according to Paragraph 8.1.3.3. when tested as specified in Paragraph 8.1.3.4.

8.1.3.2 Certification:

8.1.3.2.1 The test facility used for the certification test shall have a stabilized temperature of $20 \pm 2^\circ\text{C}$ during the test.

8.1.3.2.2 The temperature of the certification area shall be measured at the time of certification and recorded in a certification report.

8.1.3.3 Requirements

8.1.3.3.1 When the flexible lower legform impactor is used for the test according to Paragraph 8.1.3.4., the absolute value of the maximum bending moment of the tibia at

- (a) Tibia-1 shall be $230\text{Nm} \leq 272\text{Nm}$,
- (b) Tibia-2 shall be $210\text{Nm} \leq 252\text{Nm}$,
- (c) Tibia-3 shall be $166\text{Nm} \leq 192\text{Nm}$,
- (d) Tibia-4 shall be $93\text{Nm} \leq 108\text{Nm}$.

The absolute value of the maximum elongations of

- (a) MCL shall be $17.0 \leq 21.0\text{mm}$,
- (b) ACL shall be $8.0 \leq 10\text{mm}$,
- (c) PCL shall be $4.0 \leq 6.0\text{mm}$.

For all these values for the maximum bending moment and the maximum elongation, the readings used shall be from the initial impact timing to 50ms after the impact timing.

- 8.1.3.3.2 The instrumentation response value CFC, as defined in ISO 6487:2002, shall be 180 for all transducers. The CAC response values, as defined in ISO 6487:2002, shall be 30mm for the knee ligament elongations and 400Nm for the tibia bending moments.
- 8.1.3.4 Test Procedure
- 8.1.3.4.1 The assembled flexible lower legform impactor (with the flesh and skin) shall be hung vertically and freely suspended from a test rig as shown in Figure 33. It is then impacted by the upper edge of a linearly guided aluminium honeycomb impactor, covered by a thin paper cloth with a maximum thickness of 1mm, at an impact speed of 11.1 ± 0.2 m/s. The legform shall achieve a free flight condition within 10ms after the time of first contact of the honeycomb impactor.
- 8.1.3.4.2 The honeycomb of 5052 alloy, which is attached in front of the moving ram, shall be 200 ± 5 mm wide, 160 ± 5 mm high and 60 ± 2 mm deep and shall have a crush strength of $517.1\text{kPa} \pm 10\%$ (75 pound per square inch (psi) $\pm 10\%$). The honeycomb should have cell sizes of either 4.76mm (3/16 inch) or 6.35mm (1/4 inch) and a density of 32.0kg/m^3 (2.0 pound per cubic foot (pcf)) for the 4.76mm (3/16 inch) cell size or a density of 36.8kg/m^3 (2.3 pound per cubic foot (pcf)) for the 6.35mm (1/4 inch) cell size.
- 8.1.3.4.3 The upper edge of the honeycomb face shall be in line with the rigid plate of the linearly guided impactor. At the time of first contact, the upper edge of the honeycomb shall be in line with the knee joint center line within a vertical tolerance of ± 2 mm. The honeycomb shall not be deformed before the impact test.
- 8.1.3.4.4 At the time of the first contact, the flexible lower legform impactor pitch angle (rotation around the Y-axis) and, therefore, the pitch angle of the velocity vector of the honeycomb impactor shall be within a tolerance of $\pm 2^\circ$ in relation to the lateral vertical plane. The flexible lower legform impactor roll angle (rotation around the X-axis) and, therefore, the roll angle of the honeycomb impactor shall be within a tolerance of $\pm 2^\circ$ in relation to the longitudinal vertical plane. The flexible lower legform impactor yaw angle (rotation around the Z-axis) and, therefore, the yaw angle of the velocity vector of the honeycomb impactor shall be within a tolerance of $\pm 2^\circ$.
- 8.2 **Upper legform impactor certification:**
- 8.2.1 The upper legform impactor shall meet the requirements specified in paragraph 8.2.3 when tested as specified in paragraph 8.2.4.

8.2.2 Calibration

- 8.2.2.1 The foam flesh for the test impactor shall be stored for a period of at least four hours in a controlled storage area with a stabilized humidity of 35 ± 10 per cent and a stabilized temperature of $20^\circ \pm 2^\circ\text{C}$ prior to impactor removal for calibration. The test impactor itself shall have a temperature of $20^\circ \pm 2^\circ\text{C}$ at the time of impact. The temperature tolerances for the test impactor shall apply at a relative humidity of 40 ± 30 per cent after a soak period of at least four hours prior to their application in a test.
- 8.2.2.2 The test facility used for the calibration test shall have a stabilized humidity of 40 ± 30 per cent and a stabilized temperature of $20^\circ \pm 4^\circ\text{C}$ during calibration.
- 8.2.2.3 Each calibration shall be completed within two hours of when the impactor to be calibrated is removed from the controlled storage area.
- 8.2.2.4 The relative humidity and temperature of the calibration area shall be measured at the time of calibration, and recorded in a calibration report.

8.2.3 Requirements

- 8.2.3.1 When the impactor is propelled into a stationary cylindrical pendulum the peak force measured in each load transducer shall be not less 1.20 kN and not more than 1.55 kN and the difference between the peak forces measured in the top and bottom load transducers shall not be more than 0.10 kN. Also, the peak bending moment measured by the strain gauges shall not be less than 190 Nm and not more than 250 Nm on the centre position and not less than 160 Nm and not more than 220 Nm for the outer positions. The difference between the upper and lower peak bending moments shall not be more than 20 Nm.

For all these values the readings used shall be from the initial impact with the pendulum and not from the arresting phase. Any system used to arrest the impactor or pendulum shall be so arranged that the arresting phase does not overlap in time with the initial impact. The arresting system shall not cause the transducer outputs to exceed the specified CAC.

- 8.2.3.2 The instrumentation response value CFC, as defined in ISO 6487:2002, shall be 180 for all transducers. The CAC response values, as defined in ISO 6487:2002, shall be 10 kN for the force transducers and 1000 Nm for the bending moment measurements.

8.2.4 Test procedure

- 8.2.4.1 The impactor shall be mounted to the propulsion and guidance system, by a torque limiting joint. The torque limiting joint shall be set so that the longitudinal axis of the front member is perpendicular to the axis of the guidance system, with a tolerance of $\pm 2^\circ$, with the joint friction torque set to 675 ± 25 Nm. The guidance system shall be fitted with low friction guides that allow the impactor to move only in the specified direction of impact, when in contact with the pendulum.

- 8.2.4.2 The impactor mass shall be adjusted to give a mass of 12 ± 0.1 kg, this mass includes those propulsion and guidance components which are effectively part of the impactor during impact.
- 8.2.4.3 The centre of gravity of those parts of the impactor which are effectively forward of the torque limiting joint, including the extra weights fitted, shall lie on the longitudinal centerline of the impactor, with a tolerance of ± 10 mm.
- 8.2.4.4 The impactor shall be certified with previously unused foam.
- 8.2.4.5 The impactor foam shall not be excessively handled or deformed before, during or after fitting.
- 8.2.4.6 The impactor with the front member vertical shall be propelled horizontally at a velocity of 7.1 ± 0.1 m/s into the stationary pendulum as shown in Figure 34.
- 8.2.4.7 The pendulum tube shall have a mass of 3 ± 0.03 kg, a wall thickness of 3 ± 0.15 mm and an outside diameter of 150 mm $+1$ mm -4 mm. Total pendulum tube length shall be 275 ± 25 mm. The pendulum tube shall be made from cold finished seamless steel (metal surface plating is permissible for protection from corrosion), with an outer surface finish of better than 2.0 micrometer. It shall be suspended on two wire ropes of 1.5 ± 0.2 mm diameter and of 2.0 m minimum length. The surface of the pendulum shall be clean and dry. The pendulum tube shall be positioned so that the longitudinal axis of the cylinder is perpendicular to the front member (i.e. level), with a tolerance of $\pm 2^\circ$, and to the direction of impactor motion, with a tolerance of $\pm 2^\circ$, and with the centre of the pendulum tube aligned with the centre of the impactor front member, with tolerances of ± 5 mm laterally and ± 5 mm vertically.

8.3 **Child and adult headform impactors certification**

8.3.1 Drop test

8.3.1.1 Performance Criteria

The headform impactors shall meet the requirements specified in paragraph 8.3.2. when tested as specified in paragraph 8.3.3.

8.3.2 Requirements

8.3.2.1 When the headform impactors are dropped from a height of 376 ± 1 mm in accordance with paragraph 8.3.3. the peak resultant acceleration measured by one triaxial (or three uniaxial) accelerometer (accelerometers) in the headform impactor shall be:

- (a) for the child headform impactor not less than 245 g and not more than 300 g;
- (b) for the adult headform impactor not less than 225 g and not more than 275 g.

The acceleration time curve shall be uni-modal.

8.3.2.2 The instrumentation response values CFC and CAC for each accelerometer shall be 1000 Hz and 500 g respectively as defined in ISO 6487:2002.

8.3.2.3 Temperature conditions

The headform impactors shall have a temperature of $20 \pm 2^\circ\text{C}$ at the time of impact. The temperature tolerances shall apply at a relative humidity of 40 ± 30 per cent after a soak period of at least four hours prior to their application in a test.

8.3.2.4 After complying with the certification test, each headform impactor can be used for a maximum of 20 impact tests.

8.3.3 Test Procedure

8.3.3.1 The headform impactor shall be suspended from a drop rig as shown in Figure 35.

8.3.3.2 The headform impactor shall be dropped from the specified height by means that ensure instant release onto a rigidly supported flat horizontal steel plate, over 50 mm thick and over 300 X 300 mm square which has a clean dry surface and a surface finish of between 0.2 and 2.0 micrometers.

8.3.3.3 The headform impactor shall be dropped with the rear face of the impactor at the test angle specified in paragraph 7.3.4.7. for the child headform impactor and in paragraph 7.3.5.7. for the adult headform impactor with respect to the vertical as shown in Figure 35. The suspension of the headform impactor shall be such that it does not rotate during the fall.

8.3.3.4 The drop test shall be performed three times, with the headform impactor rotated 120° around its symmetrical axis after each test.

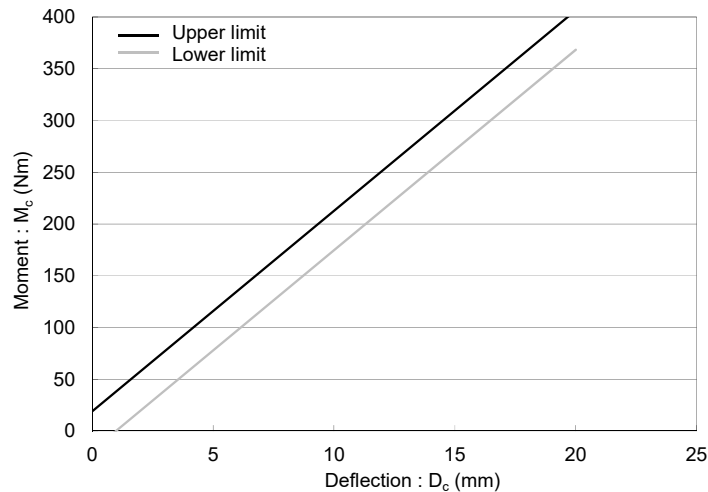

(a) Femur bending corridor

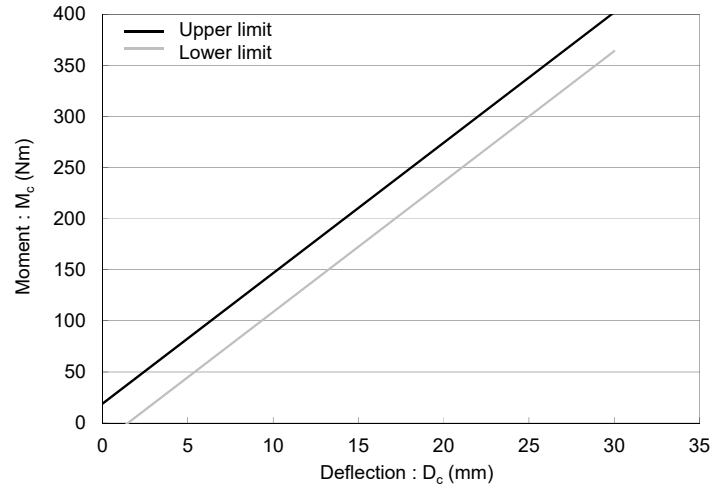

(b) Tibia bending corridor

Figure 27
Flexible lower legform impactor: Requirement corridors of the femur and the tibia in the static certification test

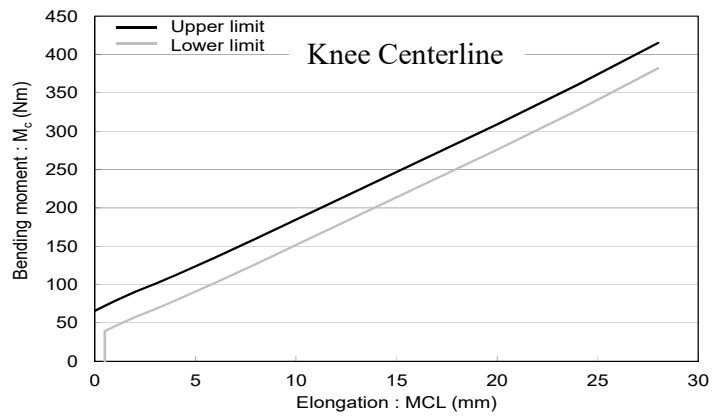

(a) for MCL

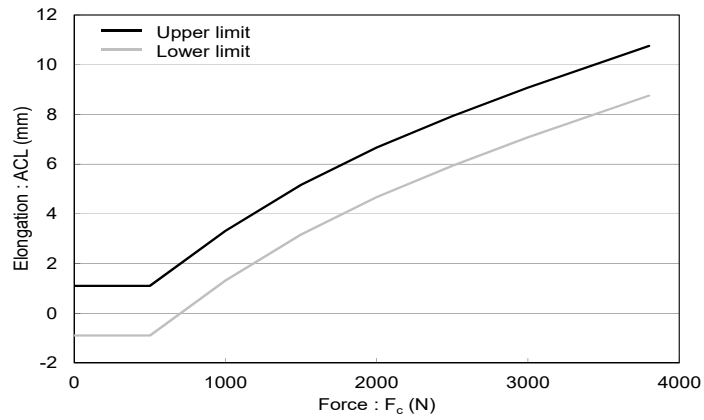

(b) for ACL

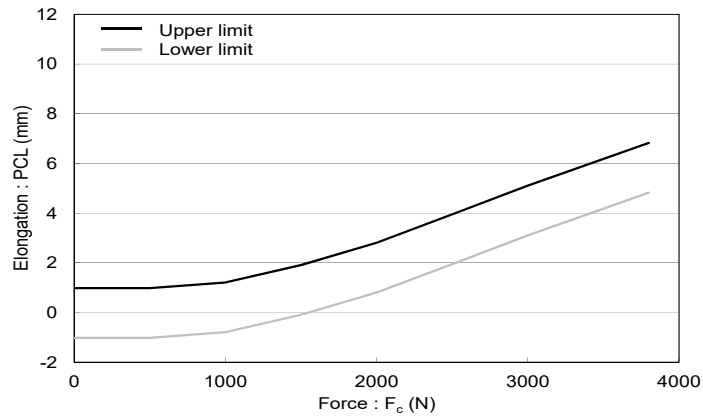

(c) for PCL

Figure 28
Flexible lower legform impactor: Requirement corridors for the knee joint in the static certification test

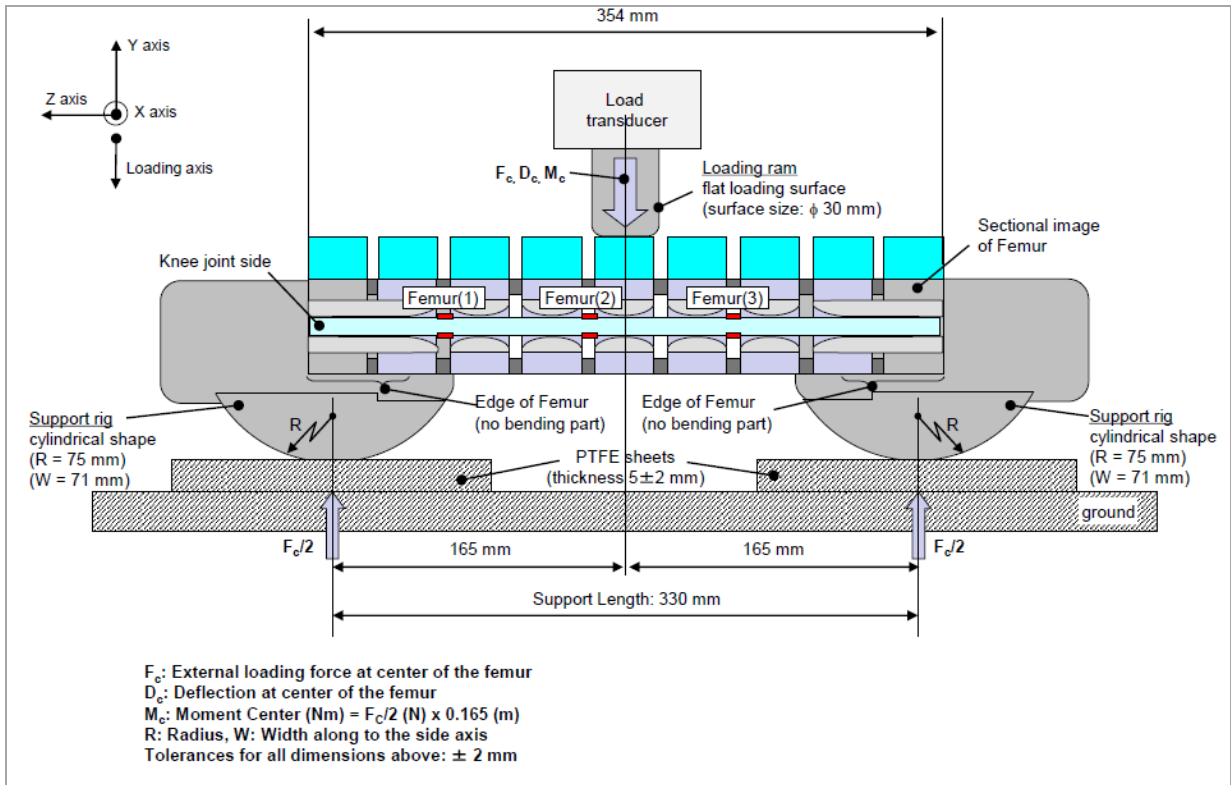

Figure 29
Flexible lower legform: Impactor test set-up for the femur in the static certification test

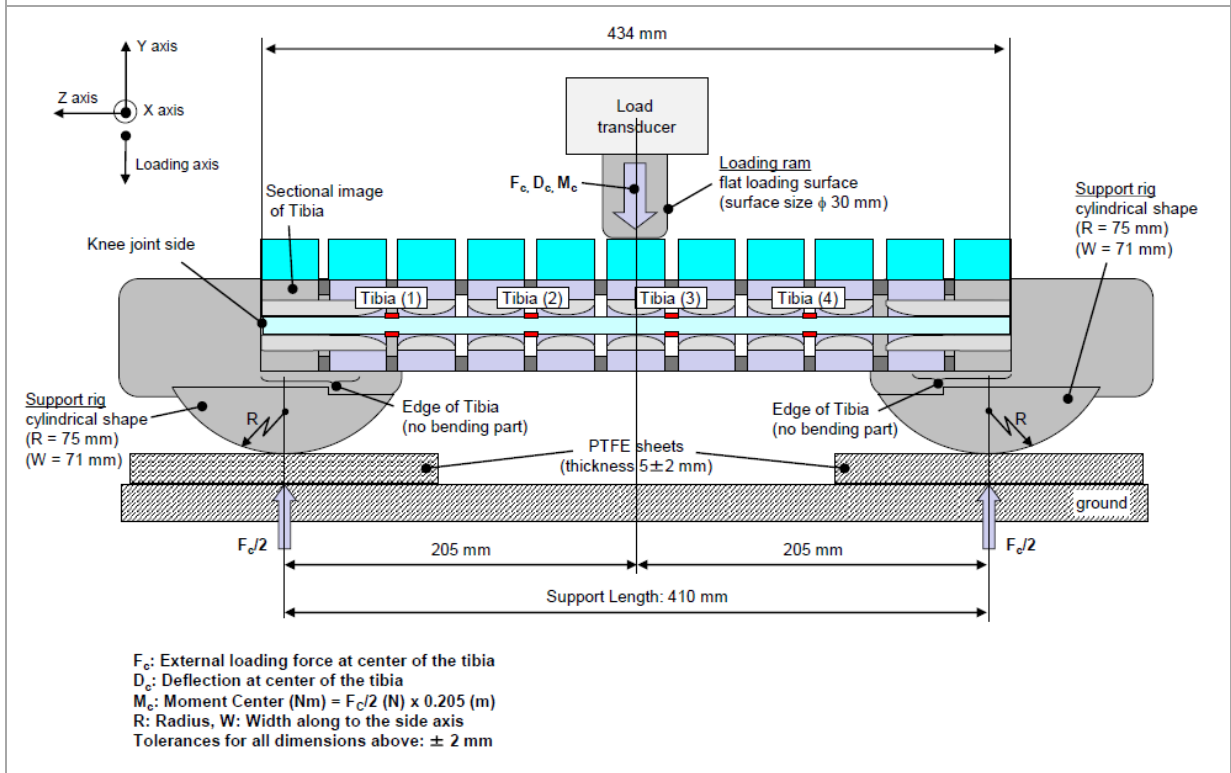

Figure 30
Flexible lower legform impactor: Test set-up for the tibia in the static certification test

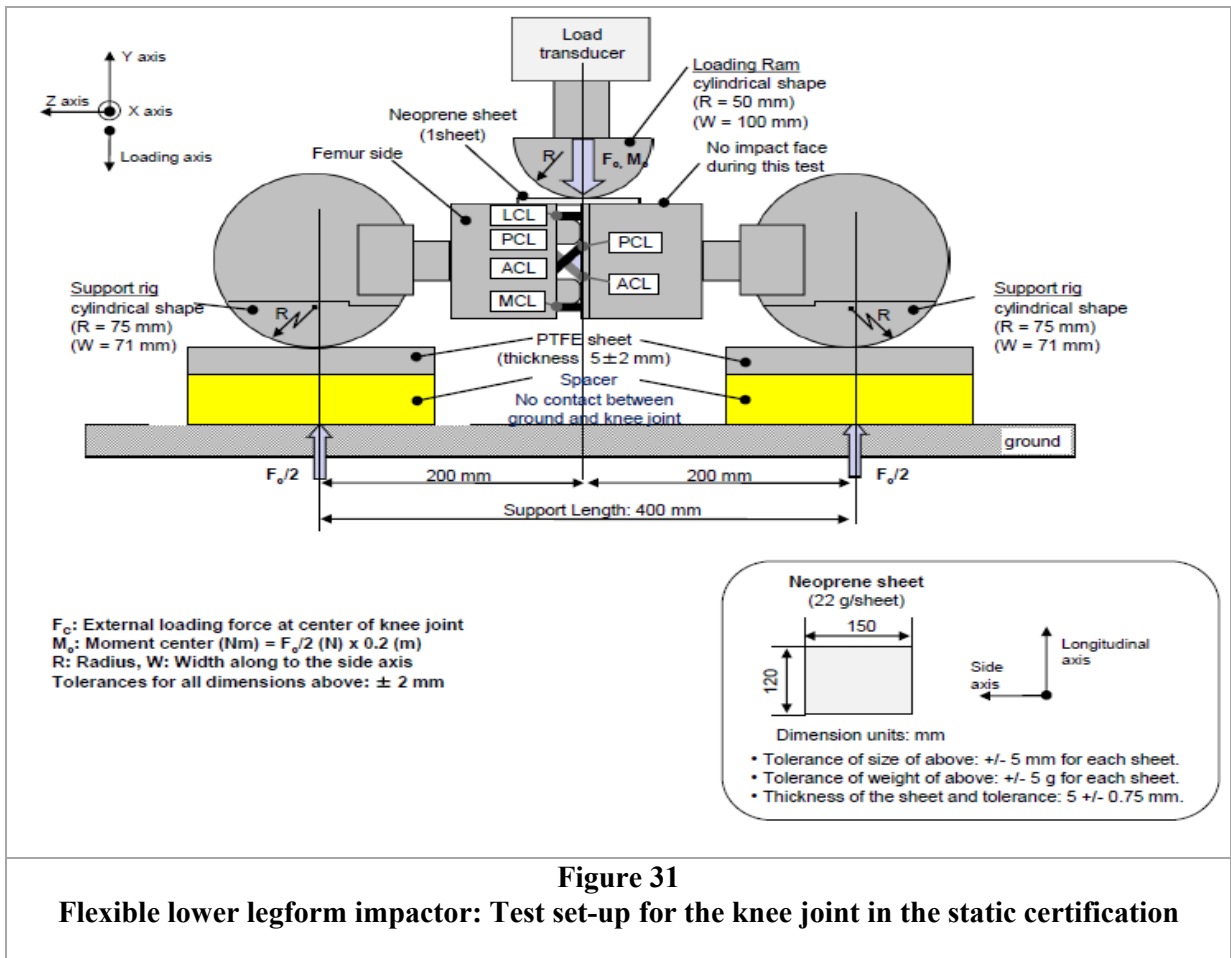

Figure 31

Flexible lower legform impactor: Test set-up for the knee joint in the static certification

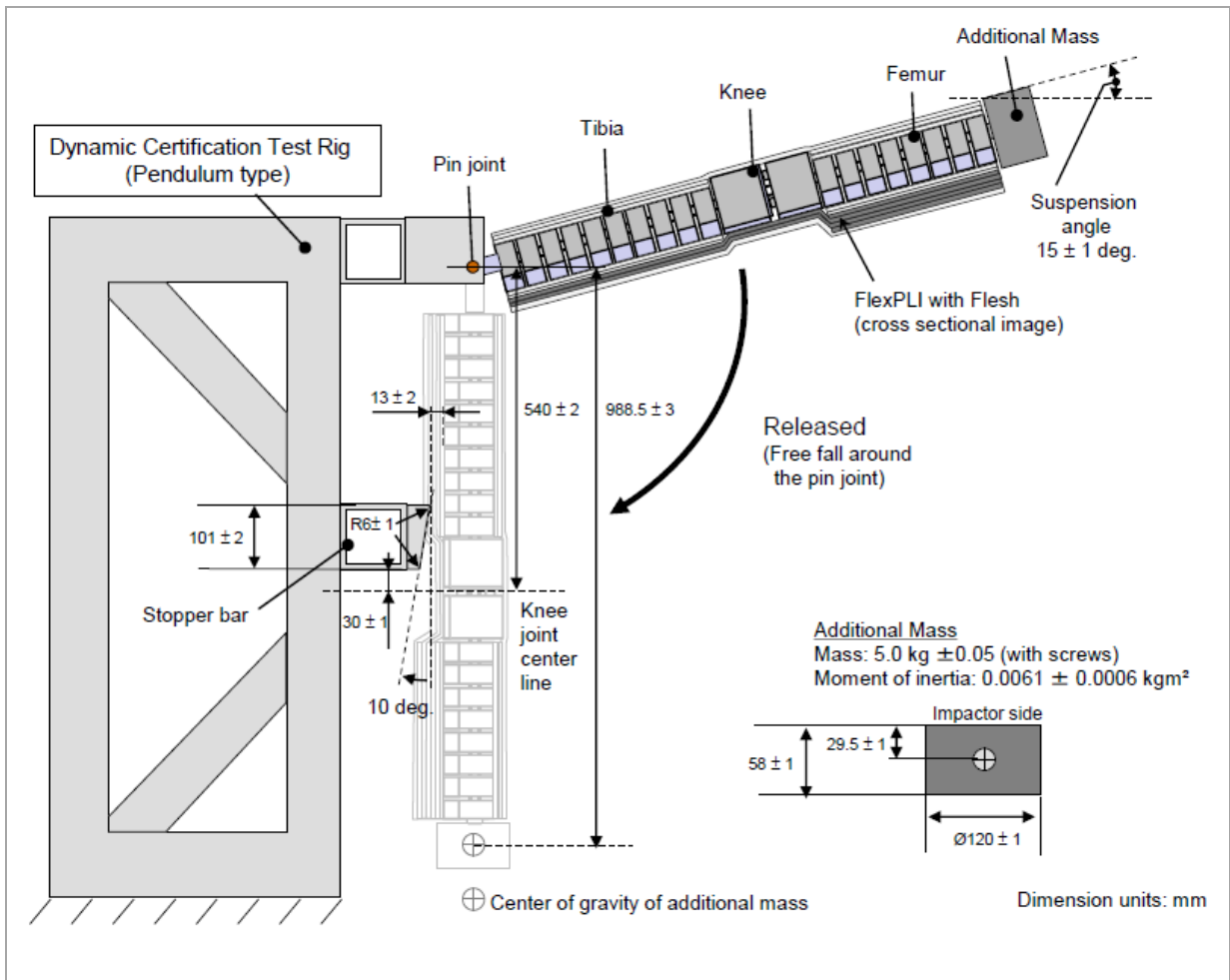

Figure 32

Flexible lower legform impactor: Test set-up for the dynamic lower legform impactor certification test – Pendulum Test

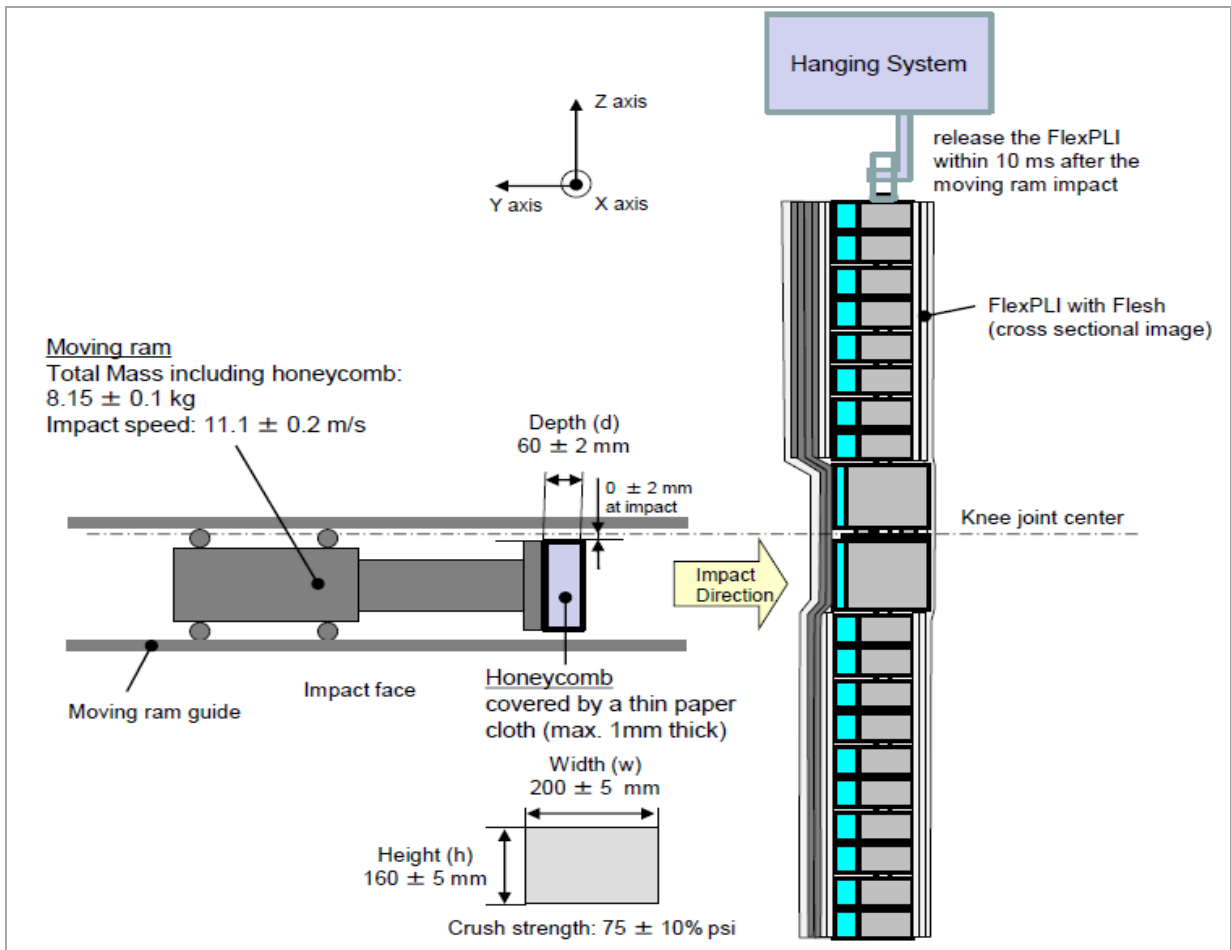

Figure 33
Flexible lower legform impactor: Test set-up for the dynamic lower legform impactor certification test – Inverse Test

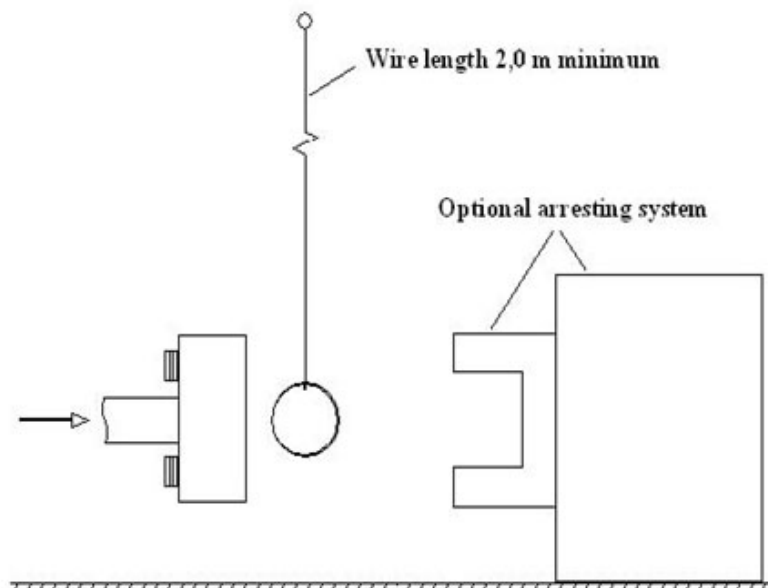

Figure 34
Test Set Up for Dynamic Upper Legform Certification Test

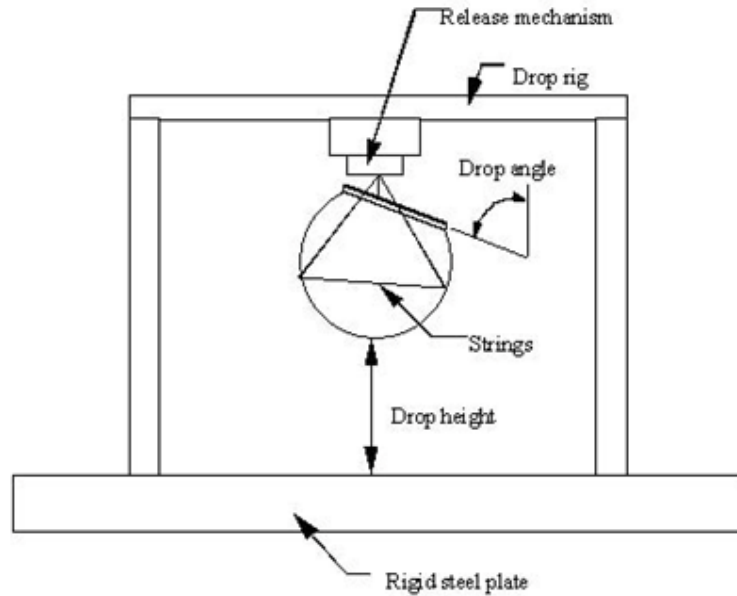

Figure 35
Test Set Up for Dynamic Headform Impactor Bio Fidelity Test

9. APPLICATION FOR APPROVAL

- 9.1 The application for approval of a vehicle type with regard to the protection of the pedestrian & vulnerable road users in the event of a collision with the motor vehicle shall be submitted by the vehicle manufacturer or by his duly accredited representative.
- 9.2 The application for approval must be accompanied with the information listed in Annex A.
- 9.3 A complete vehicle representative of the type to be approved shall be submitted to the Test Agency responsible for conducting the approval test. It should accompany sufficient quantity of the parts which would require replacements during the tests such as:
- 9.3.1 Bonnets,
 - 9.3.2 Head lamps,
 - 9.3.3 Bumpers, grills, bezels & energy absorbing structures if any,
 - 9.3.4 Windshield wiper systems,
 - 9.3.5 Engine covers,
 - 9.3.6 Affected under bonnet fitments,
 - 9.3.7 Actuators for active protection systems,

10 APPROVAL

- 10.1 If the vehicle type submitted for approval pursuant to this standard meets the requirements of Paragraph 5 above, approval of that vehicle type shall be granted.
- 10.2 In case of doubt, account shall be taken, when verifying the conformity of the vehicle to the requirements of this standard, of any data or test results provided by the manufacturer which can be taken into consideration in validating the approval test carried out by the testing agency.

11. MODIFICATIONS AND EXTENSION OF APPROVAL OF THE VEHICLE TYPE

- 11.1 Any modification of the vehicle type, with regards to protection of pedestrian in the event of a collision with a motor vehicle, shall be notified to the test agency which granted the approval. The test agency may then either:
 - 11.1.1 consider that the modifications are unlikely to have any appreciable adverse effect and that in any case the vehicle still conforms to requirements. while deciding this, guidelines explained in Annex B shall be followed;
 - or
 - 11.1.2 Require a further test report.
- 11.2 In case of 11.1.2, tests for only those parameters which are affected by the modifications shall be carried out.
- 11.3 In case of fulfillment of criteria of para. 11.1.1 or after successful results of further verification as per para 11.1.2, the approval of compliance shall be extended for the changes carried out.
- 11.4 Vehicles certified with Upper legform impactor or FlexPLI lower legform impactor and applicable headform impactors as per AIS-100 can be considered to meet the requirements of AIS-100 (Rev. 1).

12 CRITERIA FOR SELECTION OF WORST CASE AND EXTENSION OF APPROVALS

The purpose of the paragraph is to set out guidelines for selection of the worst-case configuration among the many configurations being approved within a vehicle type and to identify criteria for extensions of approval which may help the testing agency under 11.1. The guidelines are tabulated in Annex B.

- 12.1 Any other parameter can be considered as criteria for extension of approval if it is mutually agreeable to the testing agency & the vehicle manufacturer.

ANNEX A

(See 9.2)

**INFORMATION TO BE PROVIDED WITH APPLICATION FOR
TYPE APPROVAL OF A VEHICLE WITH RESPECT TO
PEDESTRIAN PROTECTION**

A.1	The following information and list of contents, if applicable, must be supplied.
A.2	If the systems, components or separate technical units have electronic controls, information concerning their performance must be supplied.
A.3	GENERAL
A.3.1	Make (trade name of manufacturer):
A.3.2	Type and general commercial description(s):
A.3.3	Category of vehicle (as per AIS-053 / IS 14272):
A.4	GENERAL CONSTRUCTION CHARACTERISTICS OF THE VEHICLE
A.4.1	Unladen Kerb mass of the vehicle & its distribution over the axles:
A.4.2	Photographs and/or drawings of a representative vehicle:
A.4.3	Position and arrangement of the engine:
A.4.4	Details of the position of references on the vehicle structure which defines the normal ride attitude of the vehicle as per the condition defined in paragraph 3.29.
A.5	BODYWORK
A.5.1	Type of bodywork:
A.5.2	Materials used and methods of construction:
A.5.3	Pedestrian protection:
A.5.4	A detailed description, including photographs and/or drawings, of the vehicle with respect to the structure, the dimensions, the relevant reference lines and the constituent materials of the frontal part of the vehicle (exterior) & mounted components shall be provided. This description should include detail of any active protection system installed.

ANNEX B

(See 11.1.1)

**GUIDELINES FOR SELECTION OF PEDESTRIAN IMPACTOR TESTS
FOR CHANGE IN THE VEHICLE TYPE**

Parameter	Change	Test not required
B.1 Bumper design	Change in the bumper material,	Headform tests
	Change in bumper profile	
	Change in the bumper cross section	
	Change in the gap behind the bumper	
B.2 Bonnet design	Change in the bonnet material	Legform tests
	Change in the underbonnet gaps beyond WAD 1000	
B.3 Change in wrap around distance lines	WAD 1000 moved rearwards more than 82.5 mm	Legform tests

ANNEX C
(See Introduction)

COMPOSITION OF AISC PANEL *
Automotive Industry Standards Sub Committee on Pedestrian safety

Panel convener	Representing
Mr. C Anilkumar	SIAM (Tata Motors Ltd.)
Members	
Mr. A. V. Mannikar	The Automotive Research Association of India
Mr. Sanjay S. Nibandhe	The Automotive Research Association of India
Mr. B. S. Yamgar	The Automotive Research Association of India
Mr. Vishal P. Rawal	The Automotive Research Association of India
Mr. Lakshman S. Shiva	The Automotive Research Association of India
Mr. Kedarnath B. Panmand	The Automotive Research Association of India
Ms. Shubhangi Dalvi	Central Institute of Road Transport
Mr. Praveen Kumar	Global Automotive Research Centre
Mr. Hariharan R	Global Automotive Research Centre
Mr. Murali	Global Automotive Research Centre
Mr. Krushna Magar	Global Automotive Research Centre
Mr. Amit Kumar	International Centre for Automotive Technology
Ms. Vijayanta Ahuja	International Centre for Automotive Technology
Mr. Ashish Kumar	International Centre for Automotive Technology
Mr. Rohit Yadav	International Centre for Automotive Technology
Mr. Ved Prakash Gautam	SIAM (Ashok Leyland Ltd.)
Mr. Satyanarayana Gupta Bolisetty	SIAM (Bajaj Auto Ltd.)
Mr. Girish S. Kodoligar	SIAM (Force Motors Ltd.)
Mr. S. Muthu Kumar	SIAM (Honda Cars R&D India Ltd.)
Mr. Satyanarayana	SIAM (Hyundai Motor India Ltd.)
Mr. P S Vatsalya	SIAM (Hyundai Motor India Ltd.)
Mr. Rahul Rijhwani	SIAM (Isuzu Motors India)
Mr. Praveen Kumar	SIAM (Isuzu Motors India)
Mr. Alauddin Ali	SIAM (Jaguar Land Rover India Ltd.)
Mr. S. Muthukumar	SIAM (Mahindra Truck & Bus Div.)
Mr. Sudhir Sathe	SIAM (Mahindra & Mahindra Ltd.)
Mr. Shailesh Kulkarni	SIAM (Mahindra & Mahindra Ltd.)
Mr. Thangaraj Karuppasamy	SIAM (Mahindra & Mahindra Ltd.)
Mr. Devinder Tangri	SIAM (Mahindra & Mahindra Ltd.)
Ms. Pushpanjali Pathak	SIAM (Mahindra & Mahindra Ltd.)
Mr. Dhotre Abhijit	SIAM (Mahindra & Mahindra Ltd)
Mr. Venkatesh G	SIAM (Mahindra & Mahindra Ltd)

Mr. Alok Jaitley	SIAM (Maruti Suzuki India Ltd.)
Mr. Gururaj Ravi	SIAM (Maruti Suzuki India Ltd.)
Mr. Amit Singh	SIAM (Maruti Suzuki India Ltd.)
Mr. Arun Kumar	SIAM (Maruti Suzuki India Ltd.)
Mr. Sumit Kumar	SIAM (Maruti Suzuki India Ltd.)
Mr. Amit Singh	SIAM (Maruti Suzuki India Ltd.)
Mr. Tarun Nagar	SIAM (Mercedes Benz India Pvt. Ltd.)
Mr. Nikhil Desai	SIAM (Mercedes Benz India Pvt. Ltd.)
Mr. Rajendra Khile	SIAM (Renault Nissan India Pvt. Ltd.)
Mr. S. Vivekraj	SIAM (Renault Nissan India Pvt. Ltd.)
Mr. Makarand Brahme	SIAM (Skoda Auto VW Ind. Pvt. Ltd.)
Mr. Aditi Deshpande	SIAM (Skoda Auto VW Ind. Pvt. Ltd.)
Mr. Milind K. Jagtap	SIAM (Skoda Auto VW Ind. Pvt. Ltd.)
Mr. Pratyush Khare	SIAM (Tata Motors Ltd.)
Mr. P. S. Gowrishankar	SIAM (Tata Motors Ltd.)
Mr. Atul A. Date	SIAM (Tata Motors Ltd.)
Mr. Vinay Maurya	SIAM (Tata Motors Ltd.)
Ms. Namrata Deb	SIAM (Tata Motors Ltd.)
Mr. Rahul Pathak	SIAM (Tata Motors Ltd.)
Mr. B. Sudarshan	SIAM (Tata Motors Ltd.)
Mr. Ganesh Gadekar	SIAM (Tata Motors Ltd.)
Mr. Raju M	SIAM (Toyota Kirloskar Motor Pvt. Ltd.)
Mr. Vijeth Gatty	SIAM (Toyota Kirloskar Motor Pvt. Ltd.)
Mr. Dinesh G. M	SIAM (Toyota Kirloskar Motor Pvt. Ltd.)
Mr. Pavan V	SIAM (Toyota Kirloskar Motor Pvt. Ltd.)
Mr. Pradeep E P	SIAM (Toyota Kirloskar Motor Pvt. Ltd.)
Mr. Tarun Bhat	SIAM (Honda Cars India Ltd.)
Mr. Mandeep	Kia India
Mr. Hitesh Sharma	MG Motors
Mr. Uday Harite	ACMA
Mr. Sivakumar Sudhachandran	ACMA (Autoliv India Pvt. Ltd.)
Mr. Boobalan Natarajan	ACMA (Autoliv India Pvt. Ltd.)
Mr. Kishor Golezar	ACMA (Nippon Audiotronix Ltd.)
Mr. Deepak M. K.	ACMA (Toyota Boshoku Auto. India (P) Ltd.)
Mr. Niladri Sekhar Samanta	Stellantis Group
Mr. Santosh Bhise	Stellantis Group
Mr. Umesh Nagraj	Valeo India

* At the time of approval of this Automotive Industry Standard (AIS)

ANNEX D
(See Introduction)

COMMITTEE COMPOSITION *
Automotive Industry Standards Committee

Chairperson	
Dr. Reji Mathai	Director, The Automotive Research Association of India
Members	Representing
Representative from	Ministry of Road Transport and Highways
Representative from	Ministry of Heavy Industries
Representative from	Office of the Development Commissioner, MSME, Ministry of Micro, Small and Medium Enterprises
Shri Shrikant R. Marathe	Former Chairman, AISC
Head TED	Bureau of Indian Standards
Director	Central Institute of Road Transport
Director	Global Automotive Research Centre
Director	International Centre for Automotive Technology
Director	Indian Institute of Petroleum
Director	Vehicles Research and Development Establishment
Director	Indian Rubber Manufacturers Research Association
Representatives from	Society of Indian Automobile Manufacturers
Representative from	Tractor and Mechanization Association
Representative from	Automotive Components Manufacturers Association of India
Representative from	Indian Construction Equipment Manufacturers' Association
Member Secretary	
Shri Vikram Tandon	The Automotive Research Association of India

* At the time of approval of this Automotive Industry Standard (AIS)