

Amendment No. 5 (08/2024)
To
AIS-093 (Revision 1):2015
Code of Practice for Construction and Approval of Truck Cabs & Truck Bodies

1.0 Section 3.0

Add following new clause 3.2.6 after clause 3.2.5

3.2.6 Wood may be permitted in the structural construction and paneling of loading platform (load body floor), provided that there exist a metal sheet for the floor panel or platform, which forms the basic floor structure of the loading platform, upon which the wooden loading platform gets mounted.

PRINTED BY
THE AUTOMOTIVE RESEARCH ASSOCIATION OF INDIA
P. B. NO. 832, PUNE 411 004
ON BEHALF OF
AUTOMOTIVE INDUSTRY STANDARDS COMMITTEE
UNDER
CENTRAL MOTOR VEHICLES RULES - TECHNICAL STANDING COMMITTEE
SET-UP BY
MINISTRY OF ROAD TRANSPORT & HIGHWAYS
(DEPARTMENT OF ROAD TRANSPORT & HIGHWAYS)
GOVERNMENT OF INDIA
7th August 2024

Amendment No. 4 (09/2019)
To
AIS-093 (Revision 1):2015
Code of Practice for Construction and Approval of Truck Cabs & Truck Bodies

1.0 Page 2/140, Clause No. 1.1.5

Substitute following text for existing text:

1.1.5 All types of Drive away chassis without cabins built by OEMs are exempted from scope this code at drive away chassis manufacturing stage till 1st April 2020. However body builders building truck cabins on this chassis shall ensure that such cabins comply with the requirements of this standard.

2.0 Page 68/140, Clause No. 5.4.4.5.2

Substitute word and figure “Section 7.0” for word and figure “Section 8.0”

3.0 Page 105/140, Clause No. 7.4.1

Substitute words and figures “Annexure 1 or Annexure 4” for word and figure “Annexure-1”

4.0 Page 105/140, Clause No. 7.4.2

Substitute word and figure “Paragraph 7.5” for word and figure “Paragraph 8.5”

5.0 Page 105/140, Clause No. 7.5.1

Substitute following text for existing text:

The criteria, using corresponding Annexure-1 or Annexure-2 or Annexure-4, must fulfill one of the following condition, subject to paragraphs 8.5

6.0 Page 106/140,Annexure-1

Substitute following title for existing title:

ROLL OVER STABILITY/ TILTABLE TEST PROCEDURE (OPTION A)

7.0 Page 114/140,

Add new Annexure-4 after Annexure-3

**Annexure 4 : ROLL OVER STABILITY/ TILTABLE TEST
PROCEDURE (OPTION B)**

1.0 C.G. Determination of Vehicle In Unladen Condition

1.1 The Center of Gravity of vehicle shall be measured as per IS 11849:1986

2.0 C.G. Determination of Vehicle in Laden Condition By Simulation

2.1 Input Required

2.1.1 Representative/Schematic 3D CAD/FE model of cab, chassis and tanker envelope.

2.1.2 Vehicle kerb mass and GVW

2.1.3 Type of liquid to be carried and its mass density

2.1.4 C.G. of vehicle in unladen condition obtained in step 1.0 of this procedure

2.2 **Simulation Procedure**

2.2.1 From the variant list, worst case for stability to be decided based on vehicle kerb weight, gross vehicle weight and capacity of tanker.

2.2.2 In the representative tanker model, adjust the mass and center of gravity of the vehicle in unladen condition as per corresponding measured values obtained in step 1.0 of this procedure.

2.2.3 In the above tanker model, distribute the mass of liquid in the volume of tanker envelope to demonstrate the laden condition.

2.2.4 Calculate the Center of Gravity (longitudinal, lateral and vertical position) of tanker under this laden condition.

2.3 The Center of Gravity so obtained in in Paragraph 2.2 of this annexure can be used for determining stability of tanker as required in paragraph 5.4.4.5.1 and stability ratio as required in 6.9.2.8.

3.0 **Determination of overturning angle**

3.1 Rotate tanker model till the C.G. of tanker in laden condition lies in vertical plane passing tire outer surface

3.2 Measure the angle of rotation.

PRINTED BY
THE AUTOMOTIVE RESEARCH ASSOCIATION OF INDIA
P. B. NO. 832, PUNE 411 004
ON BEHALF OF
AUTOMOTIVE INDUSTRY STANDARDS COMMITTEE
UNDER
CENTRAL MOTOR VEHICLES RULES - TECHNICAL STANDING COMMITTEE
SET-UP BY
MINISTRY OF ROAD TRANSPORT & HIGHWAYS
(DEPARTMENT OF ROAD TRANSPORT & HIGHWAYS)
GOVERNMENT OF INDIA
18th September 2019

AMENDMENT No. 3 (07/2018)
To
AIS-093 (Revision 1):2015
Code of Practice for Construction and Approval of Truck Cabs & Truck Bodies

Section 1- Scope and Definitions

1. Page 2/140,

Add following new clauses 1.1.4, 1.1.5 and 1.1.6 after 1.1.3:

1.1.4 Further special purpose vehicles shall be exempted from those requirements of this standard which are incompatible with the use & special function of the said vehicle.

1.1.5 All types of Drive away chassis without cabins built by OEMs are exempted from scope this code at drive away chassis manufacturing stage till 1st October 2019. However body builders building truck cabins on this chassis shall ensure that such cabins comply with the requirements of this standard.

1.1.6 This standard shall not be mandatory to vehicles manufactured for Armed Forces, para-military forces and police forces. However, these agencies may opt for procuring vehicles complying to this standard if so desired by them.

Section 2- Truck Cab Requirements

2. Page 11/140, Clause 2.1.7

Substitute following text for existing text:

2.1.7 Driver seat / Co-occupant Seat: Driver / Co-driver seat shall comply with the requirements specified in AIS-023:"Automotive Vehicles - Seats, their Anchorages and Head Restraints for Passenger Vehicles of Categories M2, M3 and Goods Vehicles of Category N - Specifications", as amended from time to time.

In case of vehicles with 1+1 configuration (i.e., 1 Driver + 1 Co-driver) and fitted with adjustable co-driver seat, It may be permitted to adjust the Co-driver seat and or back rest to meet the sleeper berth width requirements as mentioned in clause 2.1.9.3. In such case the requirement of 280 mm between co-driver seat to dashboard as mentioned in AIS 023 clause no. 4.2.2.2 need not be met.

3. Page 12/140, Clause 2.1.12

Substitute following text for existing text:

2.1.12 Steering wheel: The chassis manufacturer shall specify the position of the steering wheel with reference to the heel point. The minimum thigh clearance (i.e. the vertical distance measured between the top of seat cushion and bottom of the steering wheel – Refer 'W' in Figure - 2) shall be 170mm. The minimum distance of lower end of steering wheel from driver seat back shall be 265 mm. (Refer 'N' in Figure - 2)

4. **Page 16/140, Clause No 2.2.10**
Substitute following note below clause 2.2.10:
Note: Truck Body Manufacturer may provide relevant internal reports or a declaration for compliance for clause 2.2.10

5. **Page 16/140, Clause No 2.2.13**
Substitute following note below clause 2.2.13:
Note: Truck Body Manufacturer may provide relevant internal reports or a declaration for compliance for clause 2.2.13

6. **Page 19/140, Table below Figure 2, Sr. No.23, in fourth column**
Substitute following text for existing text:
170(min)(considering adjustment range)

7. **Page 19/140, Table below Figure 2, Sr. No.25**
Delete Sr. No. 25 and renumber subsequent Sr.Nos.

8. **Page 21/140, Table below Figure 3, Sr. No.7**
Delete Sr. No. 7 and renumber subsequent Sr.Nos.

Section 3- Truck Load Body Requirements

9. **Page 24/140, Clause No. 3.1, Categorization of truck load bodies**
Substitute following text for existing text:

3.1 Categorization of truck load bodies

The trucks are categorized on the basis of design namely rigid axle vehicles and tractor trailer combination. Trucks are further sub-categorized on the basis of truck body construction like the following.

HSD	-	High Side Deck body
LSD	-	Low Side Deck Body
FSD	-	Fixed Side Deck or Half body
DSD	-	Drop Side Deck body
FB	-	Flat Bed or Fully open body
CLB	-	Closed Body
ALC	-	Aluminium Container
STC	-	Steel container
SPB	-	Special Purpose Body including tippers & dump trucks ,Reefer Van – Closed Container with Refrigerant unit, Tanker – Closed Tanker for any non-hazardous goods like, Water, Molasses etc., Bulker – Closed Tanker for cement carrier, Fire Attender, Sky Lift, concrete mixers, Garbage Compactor, Hook carrier, Tree Transplanter, Troop carrier.

10. Page 26/140, Clause No. 3.3.3.8, Sub clause b

Substitute following text for existing text:

b) Crash guard or head board or cab rear wall: 20% of rated pay load carried, the maximum however being 5000 kgf. This force shall be applied by means of a rigid barrier covering the whole of the headboard area inside the load body with the direction of the application of force maintained parallel to longitudinal axis of vehicle.

11. Page 27/140, Clause No. 3.4.1.2

Substitute following text for existing text:

3.4.1.2 The occupants of such a vehicle shall be protected by a screen or cab rear wall or headboard capable of withstanding without breaking, a uniformly distributed static force of 200 kgf per ton of the vehicle's permissible useful load, the maximum however being 5000 kgf. This load shall be applied by means of a rigid barrier perpendicular to the longitudinal median axis of the vehicle, covering at least the whole of the cab rear wall situated above the chassis frame, and moving parallel to that axis. This shall be in accordance with the requirements specified in AIS-029.

12. Page 28/140, Clause No. 3.4.1.3.6 and 3.4.1.3.7

Substitute following text for existing text:

3.4.1.3.6 Where a power-driven vehicle or a semi-trailer is designed to carry beams, pipes, girders, sheet metal or similar loads, the protective screen or cab rear wall or headboard shall be capable of withstanding without breaking, a uniformly distributed static force of 200 kgf per ton or of the vehicle's permissible useful load, the maximum however being 5000 kgf. This shall be in accordance with the requirements specified in AIS-029.

3.4.1.3.7 Where a vehicle is equipped with a trestle or bolster behind the cab for the purpose of supporting long loads, such as steel girders or telegraphic poles, the cab rear wall or trestle or bolster must be capable of withstanding without breaking, a uniformly distributed static force of 200 kgf per ton of the vehicle's permissible useful load, the maximum however being 5000 kgf. This shall be in accordance with the requirements specified in AIS-029.

13. Page 29/140, Clause No.3.4.9 and 3.4.10

Substitute following note below clause 3.4.9 and 3.4.10:

Note: Truck Body Manufacturer may provide relevant internal reports or a Declaration for compliance for clause 3.4.9.

14. Page 35/140, Text below figure 6-Mounting of Sub frame

Substitute following text for existing text:

Mounting

The attachments and the attachment plates are fixed to chassis using suitable bolts as recommended by vehicle manufacturer. The attachments and the

attachment plates are bolted or welded to sub frame

Section 4- Requirements Of Lighting, Illumination, Electrical Equipment and Wiring

15. Page 45/140, Clause No. 4.3.3.2

Substitute following text for existing text:

Suitable connectors shall be used for external areas which are directly exposed to atmosphere to avoid water / moisture ingress during use.

Section 5- Additional Requirements for Vehicles Carrying Dangerous and Hazardous goods with regard to their specific constructional features.

16. Page 61/140,

Add following new clause 5.3.1.7.4 after clause 5.3.1.7.3

Vehicle Tracking System: Vehicles Carrying Dangerous and Hazardous goods shall be fitted with Vehicle Tracking System as per AIS-140.

17. Page 61/140, Clause No. 5.3.1.8.1.1

Substitute following text for existing text:

5.3.1.8.1.1 The seat or berth material shall comply with flammability requirements as per IS:15061-2002 or ISO Standard 3795:1989 as amended from time to time in line with stipulations given for Sl. No. 13 of Table II of GSR 1034(E) dated 2nd Nov'16.

Section 7-Working Stability of Vehicles Meant for Carriage of Hazardous Goods

18. Page 111/140, Clause G 1.1

Substitute following formula for C_{DRi} :

$$C_{DRi} = \frac{(F_{RVi} * T_{Ni}^2)}{2}$$

19. Page 111/140, Clause G 1.2

Substitute following formula for T_i :

$$T_i = \sqrt{(T_{Ni}^2 + M_A^2)}$$

20. Page 111/140, Clause G 1.2

Substitute following formula for C_{DRESi} :

$$C_{DRESi} = \frac{C_{DGMi} * C_{DRi}}{C_{DGMi} + C_{DRi}}$$

21. Page 111/140, Clause G 1.2

Add following new formula to calculate “vehicle pseudo roll angle at wheel lift” :

$$\theta_i = \frac{A_i * T_{Ni}}{2 * C_{DRESi}}$$

22. Page 135/140,

Add following new Annexure IA after Annexure I:

ANNEXURE IA			
Compliance Report to be endorsed by Testing Agency			
CMVR Certificate Reference			
AIS – 093 Clause No.	Clause Description	Test Standards	Compliance Verified (Yes/No) Report Number in case of “Yes”
2.1.5	Hand Holds	AIS:046/2005	
2.1.7	Driver and Co- driver seat	AIS: 023/2005	
2.1.8	Safety Belt	AIS: 015/2005	
2.1.10 (cab) & 3.2.4 (load body)	Mudguards & Spray Suppression devices	AIS:013/2004	
2.1.17	Heating, Cooling & Ventilation for driver	AIS:056 (Rev. 1)/2017	
2.2.1	Survival Space	AIS:029/2004	
2.2.2	Front Under Run Protective Devices (FUPD)	AIS: 069/2006	
2.2.5	Lighting and signaling devices	AIS:008(rev.1) /2010	
2.2.6	Rear view mirrors	AIS:001/2001 & AIS:002/2001	
2.2.7	Interior Fitting	AIS:047/2009	
2.2.8	Door lock & Door hinges	IS:14225-1995	
2.2.9.2 & 2.2.11	Window glass & laminated glass	IS:2553(Part- 2)-1992	
2.2.11	Wind screen and wind screen wiping system	IS:15802-2008	
3.4.5	Retro reflective marking	AIS:089/2005 & AIS:090/2005	
3.4.6	Vehicle Lateral Protection Side (VLPS)	IS:14682-2004	
3.4.7	Rear Under Run Protection Device (RUPD)	IS:14812-2005	
4.3.1	Electrical cables	ISO 6722-2006	

AIS – 093 Clause No.	Clause Description	Test Standards	Compliance Verified (Yes/No) Report Number in case of “Yes”
4.3.2	Fuse	AIS:026 (Cl. No. 12(c)) & AIS:028 (Cl. No. 4.3.3)	
3.4.3 (phase II)	External Projection	IS:13942-1994	

PRINTED BY
 THE AUTOMOTIVE RESEARCH ASSOCIATION OF INDIA
 P. B. NO. 832, PUNE 411 004
 ON BEHALF OF
 AUTOMOTIVE INDUSTRY STANDARDS COMMITTEE
 UNDER
 CENTRAL MOTOR VEHICLES RULES - TECHNICAL STANDING COMMITTEE
 SET-UP BY
 MINISTRY OF ROAD TRANSPORT & HIGHWAYS
 (DEPARTMENT OF ROAD TRANSPORT & HIGHWAYS)
 GOVERNMENT OF INDIA
 28th July 2018

Corrigendum No. 1 (05/2018)
To
AIS-093 (Revision 1):2015
Code of Practice for Construction and Approval of Truck Cabs & Truck
Bodies

1. Page 12/140, Section 2.0, Clause No. 2.1.4.1

Substitute following text for existing text:

- 2.1.4.1 The maximum height (a) from ground to top surface of first step shall be 600 mm measured on vehicle in unladen condition. However, in case of off- road vehicles this dimension shall not be more than 700 mm.

2. Page 12/140, Section 2.0, Clause No. 2.1.9.6

Substitute following text for existing text:

The minimum distance between the roof and the upper berth, measured from top face of the berth with uncompressed cushion shall be 460 mm. Refer 'I' in Figure - 2.

3. Page 16/140, Section 2.0, Clause No. 2.1.12

Substitute following text for existing text:

- 2.2.12 **Fire extinguishers:** At least one fire extinguisher with capacity of 1 kg shall be fitted for all kind of trucks. Special provisions should be made for the trucks carrying explosive materials. Halogenated hydrocarbon type of extinguisher shall not be used as extinguishant. The fire extinguishers shall be secured against tampering and shall be easily accessible to incumbent. Also the location shall be marked clearly.

4. Page 19/140, Section 2.0, Table below Figure 2, Sr.No.8 and Sr.No. 9

Substitute following text for existing text:

8	Distance between the top of Upper Berth cushion to Roof Inner, mm (Min)	I	460 mm
9	Distance between top of lower berth (cushion uncompressed) to bottom of upper berth (Min)	J	460 mm

5. Page 21/140, Section 2.0, Table with title “Guidelines on climb facility and hand holds (in unladen condition)”, column with title “Value for on-road vehicles”

Substitute figure “600” for “550”.

PRINTED BY
THE AUTOMOTIVE RESEARCH ASSOCIATION OF INDIA
P. B. NO. 832, PUNE 411 004
ON BEHALF OF
AUTOMOTIVE INDUSTRY STANDARDS COMMITTEE
UNDER
CENTRAL MOTOR VEHICLES RULES - TECHNICAL STANDING COMMITTEE
SET-UP BY
MINISTRY OF ROAD TRANSPORT & HIGHWAYS
(DEPARTMENT OF ROAD TRANSPORT & HIGHWAYS)
GOVERNMENT OF INDIA
May 2018

Amendment No. 2 28 September 2016
To
AIS-093 (Revision 1):2015
Code of Practice for Construction and Approval of Truck Cabs & Truck Bodies

Section 1 – Scope & Definitions

1. Page 5/140, Clause 1.2.5.1

Substitute following text for existing text:

1.2.5.1 **“Axle”** as defined in clause No. 3.19 of AIS-053

2. Page 5/140, Clause 1.2.5.5

Substitute following text for existing text:

1.2.5.5 **“Two-axle group”** means an axle as defined in clause No. 3.22 of AIS-053

“Tri-axle group” means an axle as defined in clause No. 3.23 of AIS-053. **“Solo axle”** means an axle as defined in clause No. 3.21 of AIS-053.

3. Page 5/140, Clause 1.2.5.6

Substitute following text for existing text:

1.2.5.6 **“Axle-lift device”** means a device as defined under CMV Rule 93(6) (C)(ii), 1989.

4 Page 5/140, Clause 1.2.5.7

Substitute following text for existing text:

1.2.5.7 **“Retractable axle”** means an axle as defined under CMV Rule 93(6) (C)(i), 1989.

PRINTED BY
THE AUTOMOTIVE RESEARCH ASSOCIATION OF INDIA
P. B. NO. 832, PUNE 411 004
ON BEHALF OF
AUTOMOTIVE INDUSTRY STANDARDS COMMITTEE
UNDER
CENTRAL MOTOR VEHICLES RULES - TECHNICAL STANDING COMMITTEE
SET-UP BY
MINISTRY OF ROAD TRANSPORT & HIGHWAYS
(DEPARTMENT OF ROAD TRANSPORT & HIGHWAYS)
GOVERNMENT OF INDIA

28 September 2016

AMENDMENT No. 1 4 May 2016

To

AIS-093 (Revision 1):2015

Code of Practice for Construction and Approval of Truck Cabs & Truck Bodies

Section 1 – Scope & Definitions

1. Page 2/140, Clause 1.1.2 (vi)

Substitute following text for existing text:

Special Purpose Vehicles including tippers and dump trucks

2. Page 2/140, Clause 1.2.4.2

Substitute following text for existing text:

Cab: The space intended for the driver and co-driver's use and contains driver seat, co-driver seat, steering wheel, controls, instruments and other necessary devices for driving or operating the vehicle. Different types of cabs are,

3. Page 5/140, Clause 1.2.6

Substitute following text for existing text:

1.2.6 Axle configuration means Axle configurations permitted / notified under CMVR.

Section 2- Truck Cab Requirements

4. Page 9/140,

Substitute words "Driver & Co-Driver Seat" for words "Driver & Co-passenger Seat" wherever it appears in this section.

5. Page 12/140, Clause No. 2.1.4.4, Line 5

Substitute following text for existing text

Minimum step clearance including step depth (e) shall be 120 mm

6. Page 12/140, Clause No. 2.1.9.4

Substitute following text for existing text:

The edges of the berth may be rounded to radii not exceeding 270 mm. The space measured above the berth shall be measure for the maximum of 300 mm of birth width from outer surface of berth.

7. Page 12/140, Clause No. 2.1.9.5

Substitute following text for existing text:

In case twin berth have been one above the other, the minimum pitch between the two berths (measured from top face of the lower berth with uncompressed cushion and lower face of the upper berth) shall be as follows (Refer J in Figure-2) –

In case the upper berth is folding type - 460 mm

In case the upper berth is fixed type - 770 mm

8. Page 14/140, Clause No. 2.2.4.3

Substitute following text for existing text:

2.2.4.3 **Cab construction material:** Wood shall not be permitted to be used in the structural parts of cabin construction. Composite materials that meet the functional requirements may be used.

9. Page 15/140, Clause No. 2.2.7

2.2.7 Interior Fitting: Drivers work area shall meet the requirement of interior fittings in accordance with AIS-047, as amended from time to time and as notified under Rule 124 of the Central Motor Vehicles Rules, 1989

Section 3-Truck Load Body – General, Technical and Safety Requirements

10. Page 24/140, Clause No. 3.2.2

Substitute following text for existing text:

Clearances/gaps as recommended by vehicle manufacturer should be ensured in respect of tyre, wheel arch, fuel/oil checking and filling, cab (where applicable). In the case of cab and load body, the body shall be separated from cab by at-least 50mm in case of N3 and 25 mm in case of N2 category of vehicles behind as shown in Figure-4.The gap may be covered with gap seal for better aerodynamics.

11. Page 25/140, Clause No. 3.3.1

Substitute words and figures “Section-7” for figure and figures “Section-8”

12. Page 26/140, Clause No. 3.3.3.5

3.3.3.5 The sub-frame shall be angled, 'C' Section, curved or forked in the front as shown in Figure-5.

13. Page 26/140, Clause No. 3.3.3.8

Substitute following text for existing text:

3.3.3.8 The side walls and crash guard shall be constructed to bear a part of load carried on the vehicle in case of braking, turning, travel on slopes etc. as given below, which can also be proved by FEM analysis.

- a) Side walls: 15% of rated pay load carried. This force shall be applied by means of a rigid barrier covering the whole of the sidewall inside the load body with the direction of the application of force maintained perpendicular to longitudinal axis of vehicle.
- b) Crash guard or head board: 20% of rated pay load carried, the maximum however being 5000 kgf. This force shall be applied by means of a rigid barrier covering the whole of the headboard area inside the load body with the direction of the application of force maintained parallel to longitudinal axis of vehicle.
- c) Rear wall or tail gate: 15% of rated pay load carried. This force shall be applied by means of a rigid barrier covering the whole of the headboard area inside the load body with the direction of the application of force maintained parallel to longitudinal axis of vehicle.

3.3.3.8.1 During the above tests, the component under test (viz., rear wall, headboard or sidewall) may deform or crack but shall not separate from the rest of the load body.

14. Page 27/140, Clause No. 4.1.1.3

Substitute following text for existing text:

3.4.1.3.2 In height, it shall be at least 800 mm for N3 category vehicles and may be 800 mm for N2 category vehicles.

Section 4-Requirements of Lighting, Illumination, Electrical Equipment and Wiring

15. Page 43/140, Clause No. 4.1.1.3

Substitute following text for existing text:

4.1.1.3 Inspection lamp or battery operated Torch may be provided in the driver compartment. This is optional for vehicles with tiltable cab.

16. Page 43/140, Clause No. 4.1.3.1

Substitute following text for existing text:

4.1.3.1 Cab lamp or courtesy lamp on left and right hand sides shall be placed, preferably above the head level of the occupant. Alternately, one lamp in the center of the cab roof or on rear side above head level of the occupant may be provided.

17. Page 43/140, Clause No. 4.1.3.2

Substitute following text for existing text:

4.1.3.2 Exit lamps for the driver and co-driver side to enable easy entry and egress in to and out of the cabin, may be provided.

18. Page 44/140, Clause No. 4.1.4.3

Substitute following text for existing text:

- 4.1.4.3 The following lamp assemblies may be illuminated by appropriate lamps,
- Cab lamp or courtesy lamp

19. Page 45/140, Clause No. 4.3.3.2

Substitute following text for existing text:

- 4.3.3.2 Weatherproof connectors shall be used for external areas which are directly exposed to atmosphere to avoid water /moisture ingress during use.

20. Page 45/140, Clause No. 4.3.3.5

Substitute following text for existing text:

- 4.3.3.5 In case of trailers and towing vehicles the 7-pin connector according to ISO 7638, 12- pin connector -----.

21. Page 46/140, Clause No. 4.6.1

Substitute following text for existing text:

- 4.6.1 The number of lamps, their position, type and wattage used in the vehicle shall be type approved.

Section 5.0- Additional Requirements For Vehicles Carrying Dangerous And Hazardous Goods With Regard To Their Specific Constructional Features

22. Page 59/140, Clause No. 5.3.1.2.1

Substitute following text for existing text:

- 5.3.1.2.1 The size of conductors shall be large enough to avoid overheating. Conductors shall be adequately insulated. All circuits shall be protected by fuses or automatic circuit breakers. However, the following cases may be exempted

- a) from the battery to cold start and stopping systems of the engine
- b) from the battery to the alternator
- c) from the battery to the starter motor
- d) from battery to tachograph, if fitted
- e) from the battery to the power control housing of the endurance braking system, if this system is electrical or electromagnetic
- f) from the battery to the electrical lifting mechanism for lifting the bogie axle

23. Page 65/140, Clause No. 5.3.2.3

Substitute following text for existing text:

5.3.2.3 EX/II vehicles: The vehicles shall be designed, constructed and equipped so that the explosives are protected from external hazards and the weather.

24. Page 65/140, Clause No. 5.3.2.4

Substitute following text for existing text:

5.3.2.4 EX/III vehicles: In these vehicles cargo area shall be closed. The loading surface, including the front wall, shall be continuous.

25. Page 65/140, Clause No. 5.3.1.8.1.1

Substitute following text for existing text:

5.3.1.8.1.1 “-----This provision will be deemed to be met if, in accordance with the procedure specified in ISO Standard 3795:1989/IS 15061: 2002/ or any other equivalent standard, samples of the following cab components-----”

Section 8.0-Type Approval and CoP Procedure

26. Page 65/140, Clause No. 8.1.2

Substitute following text for existing text:

8.1.2 ----- It will not apply to the fully built vehicles by OEM and body builder / chassis manufacturers who are currently under the type approval and CMVR certification system within the scope of this procedure.

27. Page 119/140, Annexure I

Delete Sr. Nos 8.4,8.4.1,8.4.2,9.2,9.11,9.12,9.14,9.14.1,9.14.2,9.16,9.17,9.18, 14.0,14.1,14.2,22.0,22.1,22.2,22.3,22.4,25.0,25.1,33.2

28. Page 119/140, Annexure I, Sr. No. 31.3

Substitute following text for existing text

31.3 Co-driver seat

29. Page 128/140, Annexure I, Sr. No. 41.0 to 54.0

Substitute following text for existing text:

41.0	Head lamp
41.1	Main beam
41.1.1	Make
41.1.2	Type of lens (Glass / Plastic)

41.1.3	Identification: TAC No. / BIS License No. / E- Marking
41.1.4	Number and Colour of Lens
41.2	Dipped beam
41.2.1	Make
41.2.2	Type of lens (Glass / Plastic)
41.2.3	Identification: TAC No. / BIS License No. / E- Marking
41.2.4	Number and Colour of Lens
41.3	Head Lamp cleaning device provided (Yes / No) (For Headlamps having intensity more than 2000 lumen)
41.3.1	Cleaner Type as per AIS-083
41.3.1.1	Make
41.3.2	A list, specifying the parts which constitute the headlamp cleaner and drawings thereof, (e.g. pumps, nozzles, valves, motors and wipers);
41.3.3	A brief technical description indicating the length of the cleaning period, the consumption of cleaning fluid during the cleaning period and the minimum capacity of the container provided;
41.3.4	Capacity class of the fluid container: 25/50
41.3.5	Drawings showing the installation to a vehicle
41.3.6	Drawings showing the relative attachment between the headlamp(s) and the wiper(s), nozzle(s), or corresponding parts,
41.3.7	Drawings showing the cleaning principle employed
41.3.8	where appropriate, the part of the illuminating surface of the headlamp relevant to the cleaner shall also be shown
41.4	Bend Lighting , provided (Yes / No)
41.4.1	Cornering Lamp (if provided)
41.4.2	Make
41.4.3	Identification: TAC No. / BIS License No. / E- Marking
41.4.4	Type of lens (Glass / Plastic)
41.4.5	Number and Colour of Lens
41.5	Day Time Running Lamp (if provided)
41.5.1	Make
41.5.2	Identification: TAC No. / BIS License No. / E- Marking
41.5.3	Type of lens (Glass / Plastic)
41.5.4	Number and Colour of Lens
42.0	Front Fog Lamp
42.1	Make
42.2	Type of lens (Glass / Plastic)

42.3	Identification: TAC No. / BIS License No. / E- Marking
42.4	Number and Colour of Lens
43.0	Rear Fog Lamp
43.1	Make
43.2	Identification: TAC No. / BIS License No. / E- Marking
43.3	Number and Colour of Lens
44.0	Side Marker lamps
44.1	Make
44.2	Identification: TAC No. / BIS License No. / E- Marking
44.3	Number and Colour of Lens
45.0	Registration Plate lamp
45.1	Make
45.2	Identification: TAC No. / BIS License No. / E- Marking
45.3	Number and Colour of Lens
46.0	Position lamp / Parking Lamp – Front
46.1	Front Position Lamp
46.1.1	Make
46.1.2	Identification: TAC No. / BIS License No. / E- Marking
46.1.3	Number and Colour of Lens
46.2	Front Parking Lamp
46.2.1	Make
46.2.2	Identification: TAC No. / BIS License No. / E- Marking
46.2.3	Number and Colour of Lens
47.0	Position lamp / Parking Lamp – Rear
47.1	Rear Position Lamp
47.1.1	Make
47.1.2	Identification: TAC No. / BIS License No. / E- Marking
47.1.3	Number and Colour of Lens
47.2	Rear Parking Lamp
47.2.1	Make
47.2.2	Identification: TAC No. / BIS License No. / E- Marking
47.2.3	Number and Colour of Lens
48.0	Stop lamp (S1 / S2)
48.1	Make
48.2	Identification: TAC No. / BIS License No. / E- Marking
48.3	Number and Colour of Lens

49.0	Reversing lamp
49.1	Make
49.2	Identification: TAC No. / BIS License No. / E- Marking
49.3	Number and Colour of Lens
50.0	Direction indicator Lamp
50.1	Front
50.1.1	Make
50.1.2	Identification: TAC No. / BIS License No. / E- Marking
50.1.3	Number and Colour of Lens
50.2	Rear
50.2.1	Make
50.2.2	Identification: TAC No. / BIS License No. / E- Marking
50.2.3	Number and Colour of Lens
50.3	Side
50.3.1	Make
50.3.2	Identification: TAC No. / BIS License No. / E- Marking
50.3.3	Number and Colour of Lens
50.4	Flasher for Direction Indicators
50.4.1	Flashing Frequency (No of flashes / minute)
51.0	Hazard warning signal
51.1	Front
51.1.1	Make
51.1.2	Identification: TAC No. / BIS License No. / E- Marking
51.1.3	Number and Colour of Lens
51.2	Rear
51.2.1	Make
51.2.2	Identification: TAC No. / BIS License No. / E- Marking
51.2.3	Number and Colour of Lens
51.3	Side
51.3.1	Make
51.3.2	Identification: TAC No. / BIS License No. / E- Marking
51.3.3	Number and Colour of Lens
52.0	Reflector
52.1	Front
52.1.1	Make
52.1.2	Type

52.1.3	Identification: TAC No. / BIS License No. / E- Marking
52.1.4	Number and Colour of Lens
52.1.5	Reflective surface Area
52.1.6	Shape (Square / rectangular / circular / elliptical /other)
52.2	Rear
52.2.1	Make
52.2.2	Type
52.2.3	Identification: TAC No. / BIS License No. / E- Marking
52.2.4	Number and Colour of Lens
52.2.5	Reflective surface Area
52.2.6	Shape (Square / rectangular / circular / elliptical /other)
52.3	Side
52.3.1	Make
52.3.2	Type
52.3.3	Identification: TAC No. / BIS License No. / E- Marking
52.3.4	Number and Colour of Lens
52.3.5	Reflective surface Area
52.3.6	Shape (Square / rectangular / circular / elliptical /other)
53.0	End-outline marker lamp (Top light)
53.1	Front
53.1.1	Make
53.1.2	Type of lens (Glass / Plastic)
53.1.3	Identification: TAC No. / BIS License No. / E- Marking
53.1.4	Number and colour of Lens
53.2	Rear
53.2.1	Make
53.2.2	Type of lens (Glass / Plastic)
53.2.3	Identification: TAC No. / BIS License No. / E- Marking
53.2.4	Number and colour of Lens
41.0 to E 53.0 - Installation details.	Diagram of vehicle indicating location, reference axis, mark of apparent surface, contour of vehicle parts limiting geometric visibility of all lights and light signaling devices, location of extreme outer edges and longitudinal median plane of vehicle including following dimensions in mm. Along width of vehicle- horizontal distance between inner illuminating surfaces, distance between inner illuminating surfaces and outer most part of vehicle and distance between nearest point of illuminating surfaces of indicators and dipped-beam head lamp. Along length

	of vehicle (where applicable) – distance between the transverse plane corresponding to the longitudinal rearmost extremity to center of reference of rear indicators. Heights of highest and lowest point of illuminating surfaces.
54.0	Automotive bulbs
54.1	Head lamp bulb (main beam)
54.1.1	Make
54.1.2	Category as per AIS-034
54.1.3	Identification: TAC No. / BIS License No. / E- Marking
54.1.4	Head lamp bulb (Dipped beam)
54.1.5	Make
54.1.6	Category as per AIS-034
54.1.7	Identification: TAC No. / BIS License No. / E- Marking
54.2	Parking Lamp bulb – Front
54.2.1	Make
54.2.2	Category as per AIS-034
54.2.3	Identification: TAC No. / BIS License No. / E- Marking
54.3	Parking Lamp bulb – Rear
54.3.1	Make
54.3.2	Category as per AIS-034
54.3.3	Identification: TAC No. / BIS License No. / E- Marking
54.4	Direction indicator lamp bulb - front
54.4.1	Make
54.4.2	Category as per AIS-034
54.4.3	Identification: TAC No. / BIS License No. / E- Marking
54.5	Direction indicator lamp bulb - rear
54.5.1	Make
54.5.2	Category as per AIS-034
54.5.3	Identification: TAC No. / BIS License No. / E- Marking
54.6	Direction indicator lamp bulb - side
54.6.1	Make
54.6.2	Category as per AIS-034
54.6.3	Identification: TAC No. / BIS License No. / E- Marking

54.7	Front Position Lamp bulb
54.7.1	Make
54.7.2	Category as per AIS-034
54.7.3	Identification: TAC No. / BIS License No. / E- Marking
54.8	Rear Position Lamp (tail lamp)Bulb
54.8.1	Make
54.8.2	Category as per AIS-034
54.8.3	Identification: TAC No. / BIS License No. / E- Marking
54.9	Stop lamp bulb
54.9.1	Make
54.9.2	Category as per AIS-034
54.9.3	Identification: TAC No. / BIS License No. / E- Marking
54.10	Number plate lamp bulb
54.10.1	Make
54.10.2	Category as per AIS-034
54.10.3	Identification: TAC No. / BIS License No. / E- Marking
54.11	End out Marker bulb
54.11.1	Make
54.11.2	Category as per AIS-034
54.11.3	Identification: TAC No. / BIS License No. / E- Marking
54.12	Reversing lamp bulb
54.12.1	Make
54.12.2	Category as per AIS-034
54.12.3	Identification: TAC No. / BIS License No. / E- Marking
54.13	Stop Lamp Bulb (S3)
54.13.1	Make
54.13.2	Category as per AIS-034
54.13.3	Identification: TAC No. / BIS License No. / E- Marking
54.14	Front Fog Lamp Bulb
54.14.1	Make
54.14.2	Category as per AIS-034
54.14.3	Identification: TAC No. / BIS License No. / E- Marking
54.15	Rear Fog Lamp Bulb
54.15.1	Make
54.15.2	Category as per AIS-034
54.15.3	Identification: TAC No. / BIS License No. / E- Marking

54.16	Side Marker Lamp Bulb
54.16.1	Make
54.16.2	Category as per AIS-034
54.16.3	Identification: TAC No. / BIS License No. / E- Marking
54.17	Cornering lamp bulb (if provided)
54.17.1	Make
54.17.2	Designation Category as per AIS-034
54.17.3	Identification: TAC No. / BIS License No. / E- Marking
54.18	Day time Running lamp bulb (if provided)
54.18.1	Make
54.18.2	Designation Category as per AIS-034
54.18.3	Identification: TAC No. / BIS License No. / E- Marking
54.19	Bending lamp bulb (if provided)
54.19.1	Make
54.19.2	Designation Category as per AIS-034
54.19.3	Identification: TAC No. / BIS License No. / E- Marking

PRINTED BY
THE AUTOMOTIVE RESEARCH ASSOCIATION OF INDIA
P. B. NO. 832, PUNE 411 004

ON BEHALF OF
AUTOMOTIVE INDUSTRY STANDARDS COMMITTEE

UNDER
CENTRAL MOTOR VEHICLE RULES - TECHNICAL STANDING COMMITTEE

SET-UP BY
MINISTRY OF ROAD TRANSPORT & HIGHWAYS
(DEPARTMENT OF ROAD TRANSPORT & HIGHWAYS)
GOVERNMENT OF INDIA

4 May 2016

AUTOMOTIVE INDUSTRY STANDARD

**Code of Practice for
Construction and Approval of
Truck Cabs & Truck Bodies**

(Revision 1)



PRINTED BY
THE AUTOMOTIVE RESEARCH ASSOCIATION OF INDIA
P.B. NO. 832, PUNE 411 004

ON BEHALF OF
AUTOMOTIVE INDUSTRY STANDARDS COMMITTEE

UNDER
CENTRAL MOTOR VEHICLE RULES – TECHNICAL STANDING COMMITTEE

SET-UP BY
MINISTRY OF ROAD TRANSPORT and HIGHWAYS
(DEPARTMENT OF ROAD TRANSPORT and HIGHWAYS)
GOVERNMENT OF INDIA

October 2015

INTRODUCTION

The trucking industry is a significant lifeline of the country's economic activity. Over three million trucks traverse the length and breadth of our country, contributing immensely to movement of commodities, expansion of commerce and enhancement of the GDP. An important facet of this industry is its highly diversified character of ownership. About 90 per cent of vehicles are owned and operated by individual operators having 1 to 3 vehicles in their fleet. Also, over 70 per cent of them are owner-drivers directly depending on trucking for livelihood. There is a compelling and long-felt need to upgrade this segment in the country to enhance its efficiency as well as the safety standards.

Last two decades have witnessed phenomenal increase in economic activity in India and to keep pace with the development, there is a necessity to accommodate higher levels of transportation. Equally important is the safety of these transportation modes and means. A large majority of the truck cabs, truck bodies and trailers are constructed by units in semi-organized / unorganized sectors spread over the country. There is considerable scope to improve the design of their products and process controls. Ensuring conformity of production to type approved designs would be beneficial to the end-user and society at large.

The OE vehicle manufacturers have a large role to play to assist this segment by giving design recommendations on interface aspects, wherever necessary, in order to ensure the safety and performance levels of their vehicles after body building and when used on the road. Various aspects related with the design of the truck with respect to the cab, the load body, requirements for hazardous goods vehicles, containers and their requirements for mounting, handling and securing, requirements for trailers etc. need to be addressed in the right perspective.

A sub-committee of the CMVR - Technical Standing Committee looked into all the related aspects and formulated the “**Code of Practice for Construction & Approval of Truck Cabs, Truck Bodies**”. This sub-committee was chaired by Mr. B. Bhanot, the then Chairman of CMVR - Technical Standing Committee.

The work of the Sub-committee of the CMVR-Technical Standing Committee, was identified and respective areas were allotted to different co-ordinators from the Industry and ARAI. The subject co-ordinators had the privilege and freedom to involve as many experts in their group discussions so as to arrive at the final recommendations. The technical co-ordination work of all the groups and the secretarial work for the sub-committee was carried out by Mr. A. Akbar Badusha of ARAI.

The Automotive Industry Standards Committee (AISC) responsible for approval of this standard is given in Annexure III

The following was the scope of work handled by the individual subject coordinators.

Scope of Work	Subject Co-ordinators
Scope and Definitions	<ul style="list-style-type: none"> • A. Akbar Badusha, ARAI, • C.B.S.Menon, M/s. Ashok Leyland Ltd., • P. K. Kamat, M/s. Tata Motors Ltd.
Truck Cab requirements	<ul style="list-style-type: none"> • B. L.Thareja, M/s. Eicher Motors Ltd., • Rakesh Grover , M/s. Eicher Motors Ltd., • R. Devarajan, M/s. Ashok Leyland Ltd
Truck Load Body Requirements	
Electrical - Lighting and Illumination Requirements	<ul style="list-style-type: none"> • S.V.Suderson, Daimler India Commercial Vehicles Pvt. Ltd. • A. Akbar Badusha, ARAI
Requirements for Hazardous Goods Vehicles	
Requirements for Container Mounting, Handling & Securing	<ul style="list-style-type: none"> • C.B.S. Menon, M/s. Ashok Leyland Ltd., • P.K. Kamat, M/s. Tata Motors Ltd.
Working Stability of Vehicles	<ul style="list-style-type: none"> • A. Akbar Badusha , ARAI, • S.V.Suderson, Daimler India Commercial Vehicles Pvt. Ltd.
Type Approval & Conformity of Production	<ul style="list-style-type: none"> • A. Akbar Badusha, ARAI
Technical Specifications	<ul style="list-style-type: none"> • A. Akbar Badusha, ARAI

The sub-committee had about seven rounds of discussion on the subject to finalise the recommendations. Sufficient guidelines have been drawn from the European regulations on respective areas where ever they exist. The sincere efforts put in by the subject co-ordiinators and all other experts in the making of this detailed document is greatly appreciated. This Code would give proper guidelines for the industry to follow and make necessary changes in design and construction of vehicles to improve safety on roads.

Subsequently a panel meeting was held with all the stake holders on 29th April 2014 for discussions certain amendments which are mostly editorial. It was discussed that since these amendments more in number and that the trailer provisions have already been separated into a separate Code, it is appropriate to have this considered as Revision -1.

The Automotive Industry Standards Committee (AISC) responsible for preparation of this standard is give in Annexure-III

**Code of Practice for Construction and Approval of
Truck Cabs and Truck Bodies**

CONTENTS

Section	Details	Page No.
Section - 1	Scope and Definitions	1/139
Section - 2	Truck Cab Requirements	10/139
Section - 3	Truck Load Body Requirements	24/139
Section - 4	Electrical - Lighting and Illumination Requirements	42/139
Section - 5	Requirements for Hazardous Goods Vehicles	56/139
Section - 6	Requirements for Container Mounting, Handling & Securing	73/139
Section - 7	Working Stability of Vehicles meant for the carriage of Hazardous Goods	102/139
Section - 8	Type Approval & Conformity of Production	114/139
Annexure - I	Technical Information on Truck Cab, Load Body & Related Technical Features	118/139
Annexure - II	Technical Information of Vehicles Carrying Hazardous Goods	134/139
Annexure - III	Automotive Industry Standards Committee Composition	139/139

SECTION - 1.0
SCOPE AND DEFINITIONS
LIST OF CONTENTS

1.1	Scope
1.2	Definitions
1.2.1	Vehicle and their Categories.
1.2.2	Chassis
1.2.3	Weights
1.2.4	Driver's Cab and related areas
1.2.5	Axle and Types
1.2.6	Axle Configuration
1.2.7	Truck Trailer and Types
1.2.8	Seats and their related areas
1.2.9	Lighting and Illuminations
1.2.10	Components of Body Structure

1.1 SCOPE

1.1.1 The provision of the code shall be applicable to trucks of Gross Vehicle Weight (GVW) above 3.5 tonnes. The requirements shall not apply to the special purpose vehicles of the following categories as defined in CMVR, except in respect of those provisions, which are not compatible with the intended use and function of these vehicles.

- (i) Category N2
- (ii) Category N3

1.1.2 The requirement of this code shall apply to the following types of truck bodies used in conjunction with the categories of trucks referred in Para1.1.1.

- (i) Flat Bed or Full Open Body
- (ii) Semi Open or Half Body
- (iii) High Side Deck Body
- (iv) Closed Body
- (v) Bodies for Carrying ISO Tankers
- (vi) Special Purpose Vehicles.

1.1.3 In respect of those provisions which are exclusively meant for the use and function of special purpose vehicles, the requirements shall be notified separately by the appropriate authorities.

1.2 DEFINITIONS

The definitions stated here shall apply only for this code. These are the definitions that may commonly apply to all the chapters of the code.

1.2.1 Vehicle and their Categories

1.2.1.1 **“Articulated vehicle”** means a vehicle, which consists of two or more rigid sections, which articulate relative to each other, a coupling interconnects the tractor and the super structure of trailer or the superstructures of truck and the trailer or superstructure of trailers. The rigid sections are permanently connected and can only be separated by an operation involving facilities, which are normally found in a workshop.

1.2.1.2 **“Combination vehicle”** means motor truck or tractor coupled to one or more trailer including semi-trailers.

1.2.1.3 **“Tractor”** means a motor vehicle designed primarily for drawing Truck trailers and constructed so as to carry part of the weight and load of a semi-trailer

1.2.2 Chassis

1.2.2.1 **“Drive away chassis vehicle”** means the basic operating motor vehicle including engine, frame, and other essential structural and mechanical parts, but exclusive of cab and body or body and all appurtenances for

the accommodation of driver, property or passengers, appliances, or equipment related to other than control.

- 1.2.2.2 **“Ladder type chassis”** means the chassis frame of the vehicle and is the main load-bearing element. The general construction of ladder frame consists of side long members and cross members. The side long members and cross members are connected with special gusset sections or pressed cross member sections. The junctions are riveted, bolted or welded.
- 1.2.2.3 **“Monocoque construction”** means a type of truck body structure where the cab, body and base frame are joined together either by welding or by other methods to form an integral structure. These structural elements may consist of pressed grid type of support elements and rectangular sections.
- 1.2.2.4 **“Cab & chassis”** means an incomplete vehicle, with a completed occupant compartment, that requires only the addition of cargo carrying and load bearing components to perform its intended functions.
- 1.2.2.5 **“Cowl & chassis”** means an incomplete vehicle, with the fitment of a front end structure with or without the windshield that requires the building of the complete cab and the cargo carrying or load bearing components to perform its intended functions.
- 1.2.2.6 **“Truck body”** means the structure or fixture specially provided to contain, or support, the load to be transported on a motor truck or a trailer.

1.2.3 Weights

- 1.2.3.1 **“Unladen kerb weight”** means weight of vehicle with cab and body, fitted with all electrical equipment & auxiliary equipments necessary for normal operation of the vehicle plus weight of the elements which the vehicle manufacturer provides as a standard or option equipment which shall be specified in list plus mass of the following elements
- a) lubricants
 - b) coolant (if needed)
 - c) fuel (tank filled at least 90% of capacity specified by manufacturer)
 - d) standard tool kit
 - e) standard spare parts
 - f) spare wheel and
 - g) fire extinguisher.
 - h) warning triangles
 - i) wheel chocks
- 1.2.3.2 **“Gross vehicle weight”** means technically permissible maximum weight declared by the manufacturer of the vehicle.
- 1.2.3.3 **“Gross combined vehicle weight”** means total weight of the truck and trailer or tractor and trailer or semi-trailer with payload.

1.2.3.4 **“Weight distribution on truck”** means the distribution of the body and payload and the relationship with respect to the permissible load on the axles.

1.2.3.5 **“Cubic capacity”** means the usable internal load carrying space as related to closed bodies, van trailers ,bulk trailers, tank trailers, containers etc.

1.2.4 **Driver’s Cab and related areas**

1.2.4.1 Cab designs are generally classified into following two types

1.2.4.1.1 **“Cab over engine (COE) or forward control (FC) cab”** : This means a vehicle in which all or substantial part of its engine is located under the cab i.e. below driver and co-driver. Also in case of cab over engine vehicles, the steering system is positioned right at the front of the vehicle.

1.2.4.1.2 **“Cab behind engine (CBE) or normal control (NC) cab or conventional cab”** : In cab-behind-engine vehicles, the engine transmission assembly is mounted ahead of the cab.

1.2.4.2 **“Cab or driver compartment”** : The space intended for the driver's exclusive use and contains driver seat, steering wheel, controls, instruments and other devices necessary for driving or operating the vehicle. Different types of cabs are,

1.2.4.2.1 **“Short conventional cab”** : When compared to the normal conventional cab, the short conventional cab has a shortened hood and front fenders and the engine extends into the cab area.

1.2.4.2.2 **“Sleeper cab”** : Truck with a sleeping compartment in the cab and the cab is incorporating with the sleeper berth for the driver/co-driver.

1.2.4.2.3 **“Tilt cab”**: Vehicle designed with the engine beneath the cab and having provision for tilting the cab forward to provide easy access to the engine.

1.2.4.2.4 **“Cab to axle of the frame (CA)”**: The dimension from the back of the cab to the centerline of the rear axle. For the tandem axle trucks, the distance from back of the cab to the centerline of the tandem cylinder.

1.2.4.2.5 **“Cab to end of the frame (CE)”**: The dimension from the back of the cab to the rear of the standard frame.

1.2.4.2.6 **“Door”** means a sub system of a Truck cab body that permits boarding and alighting for the driver and crew members.

1.2.4.2.7 **“Window”** means an aperture in the side or rear of the truck cab to let in light / air.

1.2.4.2.8 **“A pillar”** means a structural member integrating the floor, waist rail (bottom of windscreen panel) and roof

1.2.5 **Axle and Types**

1.2.5.1 “**Axle**” for the purpose of defining a vehicular wheel arrangement may be composed of either:

- (i) One beam extending across the vehicle and mounting at each end either a single wheel, a pair of dual disc wheels, or a demountable rim type wheel with dual rims; or
- (ii) Two separate and independently suspended beams located transversely across the vehicle and each mounting one of the aforementioned wheel arrangements. In either case, two single wheels or two dual wheel arrangements are considered the complement of any axle depending on whether single or dual tires are used.

1.2.5.2 “**Non-powered axle**” means an axle designed to support the portion of the vehicle weight but does not transmit a driving force to the wheels.

1.2.5.3 “**Powered axle**” means an axle designed to support a portion of the vehicle weight and to transmit a driving torque / force to wheels.

1.2.5.4 “**Steering axle**” means an axle through which directional control of the vehicle is applied. A steering axle may be powered or non-powered.

1.2.5.5 “**Two-axle group**” means a tandem axle and a “**Tri-axle group**” means a tridem axle. By convention a solo axle is considered as a group of one axle.

1.2.5.6 “**Axle- lift device**” means a device permanently fitted to a vehicle for the purpose of reducing or increasing the load on the axle(s), according to the loading conditions of the vehicle:

- Either by raising the wheels clear off the ground / lowering them to the ground, or
- Without raising the wheels off the ground, (e.g., in the case of air suspension systems, or other systems),

In order to reduce the wear on the tyres, when the vehicle is not fully laden, and /or makes starting (moving off) on slippery ground easier for motor vehicles or vehicle combinations, by increasing the load on the driving axle.

1.2.5.7 “**Retractable axle**” means an axle which can be raised / lowered by the axle lift device in accordance with 1.2.5.6, first indent.

1.2.6 Axle configuration

(Figures indicate the number of load-bearing wheels times the number of driving wheels)

1.2.6.1 4x2 Tandem-axle truck with drive on one rear axle.

1.2.6.2 4x4 Tandem-axle truck with drive on two axles.

- 1.2.6.3 6x2 Tri-axle truck with drive on one rear axle.
- 1.2.6.4 6x2/4 Tri-axle truck with drive on one rear axle and one tag axle, with steered wheels in front of the driving axle.
- 1.2.6.5 6x2/4 Tri-axle truck with drive on one rear axle and one tag axle, with steered wheels behind the driving axle.
- 1.2.6.6 6x4 Tri-axle truck with drive on two rear axles.
- 1.2.6.7 6x6 Tri-axle truck with drive on three axles.
- 1.2.6.8 8x2 Four-axle truck with twin front axles and with drive on one rear axle.
- 1.2.6.9 8x2/4 Four-axle truck with drive on one rear axle and one tag axle, with steered wheels in front of the driving axle.
- 1.2.6.10 8x2/6 Four-axle truck with twin front axles and drive on one rear axle and one tag axle, with steered wheels behind the driving rear axle.
- 1.2.6.11 8x4 Four-axle truck with twin front axles and with drive on two rear axles.
- 1.2.6.12 8x8 Four-axle truck with drive on four axles.

1.2.7 Truck Trailer and Types :

- 1.2.7.1 **“Truck trailer”** means a vehicle with or without auxiliary motive power designed to be drawn by a motor truck or truck tractor.
- 1.2.7.2 **“Semi-trailer”** means a truck trailer equipped with one or more axles, and so constructed that the front end and a substantial part of its own weight and that of its load rest upon another vehicle.
- 1.2.7.3 **“Full trailer”** means a truck trailer constructed so that all its own weight and that of its load rest upon its own wheels.
- 1.2.7.4 **“Load dividing dolly”** is coupled between a Truck Tractor and semi-trailer to reduce the load imposed by the semi-trailer on the truck tractor. It is a truck trailer with one or more axles equipped with a fifth wheel, drawbar, and other parts necessary for its use.
- 1.2.7.5 **“Trailer converter dolly”** means a truck trailer with one or more axles equipped with a fifth wheel, a draw bar, and other parts necessary to convert a semi-trailer to a full trailer

1.2.8 Seats and their related areas : All the related definitions for seats and their areas defined in AIS-023 shall be applicable

1.2.9 Lighting and Illumination :

- 1.2.9.1 **“Cab lamp or courtesy lamp”** are lamps situated above the head of the driver lighting up the dash board area and inside of the cab. This is meant for operation while the vehicle is stationary. The cab lamp shall be capable of being operated only for a momentary duration while the

vehicle is in motion.

- 1.2.9.2 **“Instrument lighting”** are lights that light up individual instruments. These can be connected to a single control through a rheostat or any other suitable means. By varying the control, the strength of the instrument lighting can be regulated by the driver while driving in the dark to avoid glare from instrument lighting.
- 1.2.9.3 **“Control unit lamps”** are similar to instrument lighting. However, these lamps illuminate individual controls discreetly to assist driver for identifying the controls.
- 1.2.9.3.1 **“Locker lamps”** are lamps to light up the inside of the locker when the door to the locker is opened, illuminating the interior of the locker.
- 1.2.9.4 **“Electrical distribution panel lamps”** are lamps meant to light up electrical distribution panel when the cover to the distribution center is opened for checking and maintenance purposes.

1.2.10 Components of Body Structure :

- 1.2.10.1 **“Cross bearers”** are structural members mounted on the chassis frame or to the long member through ‘U’ Bolts, gussets or out rigger brackets. The cross bearers transmit the body load to the chassis or to through the long member and also withstand the forces induced during the normal operation of the vehicle.
- 1.2.10.2 **“Vertical pillars”** (body pillar) are structural members that support the side structure are connected to the cross bearers through gussets. The side pillars transmit load to the cross bearers and also withstand the forces induced during the normal operation of the vehicle.
- 1.2.10.3 **“Long member”** are structural members that support the cross bearers and helps to transmit the load from cross bearers to the chassis.
- 1.2.10.4 **“U bolts”** are fasteners used for fastening the cross bearers to the chassis frame.
- 1.2.10.5 **“Outrigger”** Members are provided to transfer load of Body structure members. These are fixed to the chassis side members.
- 1.2.10.6 **“Rear gate(s) (*Rear doors/tail gate*)”** are structural members that are provided for protecting the load and also act as load bearing members to support the load. The rear doors also transmit load to the load and also withstand the forces induced during the normal operation
- 1.2.10.7 **“Head board (also called crash guard or front wall)”** are structural members that are provided for supporting the load and act as load bearing members. (Headboard, can be treated as part of the load restraint system)
- 1.2.10.8 **“Floor board”** (Platform) are structural members that are provided for supporting the load and act as load bearing members and are capable of withstanding a vertical forces acting on it during normal operation.

- 1.2.10.9 **“Side board”** (Side gates) are structural members that are provided for supporting the load and act as load bearing members and are capable of withstanding a horizontal forces(Side thrust) induced on it during normal operation. Side boards also transmit roof load in case of closed body or containers.
- 1.2.10.10 **“Bolster”** Rigid support base commonly used to support logs.
- 1.2.10.11 **“Blocking”** Material, usually timber, placed between the load and the vehicle structure, used to prevent movement of the load. (Also Baulking - “blocking”)
- 1.2.10.12 **“Chocks”** Blocks, normally wedge shaped, used to prevent movement of the truck wheels.
- 1.2.10.13 **“Dunnage”** Packing placed between the base of the load and the surface of the vehicle’s load platform. See also **“blocking”**.
- 1.2.10.14 **“Frail”** A frame for holding sheets of glass during transport.
- 1.2.10.15 **“Lashings”** Fastening devices, chains, cables, ropes or webbing used to restrain loads.
- 1.2.10.16 **“Load binder”** A device fitted to a chain or lashing used to tighten (tension) the restraint. An over-centre locking action is incorporated.
- 1.2.10.17 **“Shackle”** A metal coupling link closed by a bolt, which can be used for connecting chains to anchor points. The two principal shapes are “D” and “bow”.
- 1.2.10.18 **“Shoring bar”** Metal or wooden load-carrying beam or fabricated truss section used to restrain or transmit a load from one frame, column, post, wall or bearing point to another. It may be adjustable and also can be known as a shoring pole.
- 1.2.10.19 **“Thimble”** A metal liner, usually pear-shaped and concave on the outside which is fitted into the eye of a rope to prevent chafing and to distribute the load.
- 1.2.10.20 **“Turnbuckle”** A type of coupling fitted between the ends of a lashing or between two lashings used primarily for adjusting or regulating the tension in lashings. It consists of a loop or sleeve with a screw thread on one end and a swivel at the other. Alternatively, it has an internal screw thread at each end.
- 1.2.10.21 **“Twist lock”** A locking device designed to fasten containers to the vehicle on which they are being transported.
- 1.2.10.22 **“Crew members”** means any person(s) assigned to support the operation of the vehicle.

Note: In case if any of the above mentioned definitions are at variance with the notified definitions under Central Motor Vehicle Rules, 1989, the later shall be considered to have the final standing for all technical and administrative purposes.

SECTION - 2.0
TRUCK CAB REQUIREMENTS
LIST OF CONTENTS

2.1	General requirements of truck cab design
2.1.1	Overall Dimensions
2.1.2	External Projections
2.1.3	Driver Door
2.1.4	Climb Facility
2.1.5	Hand Holds
2.1.6	Window on Cab Door
2.1.7	Driver Seat / Co-Passenger Seat
2.1.8	Safety Belt Assemblies and Anchorages
2.1.9	Sleeper Berth
2.1.10	Mudguards / Spray suppression devices
2.1.11	Driver Work Area
2.1.12	Steering Wheel
2.1.13	Placement of Instrument Panel
2.1.14	Position of Controls
2.1.15	Stowage Space
2.1.16	First Aid Box
2.1.17	Heating, Cooling and Ventilation for Driver
2.2	Truck Cab – Technical and Safety Requirements
2.2.1	Truck Cab Structural Strength
2.2.2	Front Under run Protective Device (FUPD)
2.2.3	Cab Mounting Arrangement and Strength Requirements
2.2.4	Protection of the Occupants in the Event of a Lateral Collision
2.2.5	Lighting and signaling devices
2.2.6	Rear view mirror
2.2.7	Driver’s Work Area
2.2.8	Door Locks & Hinges
2.2.9	Window
2.2.10	Ingress of dust and rain water
2.2.11	Wind Screen and Wind Screen Wiping System
2.2.12	Fire extinguishers
2.2.13	Guidelines for Corrosion Protection

2.1 General requirements of truck cab design

2.1.1 Overall dimensions: The overall dimensions of the truck cab shall comply with the provisions laid down in Rule 93 of the Central Motor Vehicle Rules, 1989 as amended from time to time

2.1.2 External projections: The cab shall comply with the external projection requirements as per IS 13942:1994, as laid down in Rule 124 of the Central Motor Vehicles Rules, 1989, as amended from time to time.

2.1.3 Driver door

2.1.3.1 All truck cabs shall be provided with minimum two entries one for the driver and one for the co-passenger, on either sides of vehicle.

2.1.3.2 The driver and co-passenger doors shall be hinged from A-Pillar.

2.1.3.3 All doors shall be hinged at the front and shall open minimum by 65°. An opening of 650 mm minimum must be available from 'B'-Pillar, in the fully open condition.

2.1.3.4 The minimum height of the door aperture (clear opening) measured from floor to the top shall not be less than 1050 mm. In case of floor with hump, the minimum height shall be measured as clear max opening. (Refer Q in Figure - 2).

2.1.3.5 The minimum width of the door aperture measured from A Pillar to B Pillar shall be 650 mm. (Refer P in Figure - 2)

2.1.4 Climb facility: The requirements of Climb facility are as given in the table under Figure-3.

2.1.4.1 The maximum height (a) from ground to top surface of first step shall be 650 mm measured on vehicle in unladen condition. However, in case of off- road vehicles this dimension shall not be more than 700 mm.

2.1.4.2 The vertical distance (b) between top surfaces of subsequent steps shall not be more than 400 mm. The vertical distance between two subsequent steps shall not vary by more than 50 mm. The last requirement shall not apply to the distance between the uppermost step and the cab floor. For off-road vehicles, this latter value may be increased up to 100 mm and the dimension (b) shall not be more than 500 mm.

2.1.4.3 The lowest step may be designed as a rung, if this is necessary for reasons relating to construction or use, and in the case of off road vehicles. The rung thickness (t) shall be at least 20 mm or it shall be capable of withstanding minimum 140 kgf load. Rungs of round cross section are not permitted.

2.1.4.4 In addition, the following geometrical specifications shall be fulfilled:

Minimum step width (f) shall be 200 mm.

Minimum step width (g) for lower step shall be 100mm

Minimum step depth (d) shall be 80 mm.

Minimum step clearance including step depth (e) shall be 150 mm

Minimum height of uppermost step to floor (s) shall be 120 mm

2.1.4.5 Other requirements shall be as per the table under Figure - 3.

2.1.4.6 Steps need be provided with anti-slip surface, as per the relevant AIS as and when notified. In addition, steps exposed to weather and dirt during driving shall have adequate run off (draining surface).

Note: In case if there are any contradictory requirements between the requirements stated in this code and that of AIS-046, the requirements stated in AIS-046 may be considered as final and standing.

2.1.5 Hand holds

2.1.5.1 The handhold requirements shall comply with AIS-046 as amended from time to time.

2.1.5.2 Figure - 3 may be referred for guidelines.

2.1.6 Window on cab door

2.1.6.1 The window panes shall be winding type for all trucks

2.1.6.2 The minimum width of the window aperture (clear vision zone) shall be 450 mm. (Refer R in Figure - 2) and the minimum height of the window aperture (clear vision zone) shall be 400 mm. (Refer S in Figure - 2). Alternatively, the total area of the aperture shall not be less than 1800 sq. cm.

2.1.7 Driver seat / Co-occupant Seat: Driver / Co-driver seat shall comply with the requirements specified in AIS-023:"Automotive Vehicles - Seats, their Anchorages and Head Restraints for Passenger Vehicles of Categories M2, M3 and Goods Vehicles of Category N - Specifications", as amended from time to time.

2.1.8 Safety belt assemblies and anchorages: Safety belt assemblies and anchorages shall comply with the requirements laid in IS: 15140-2003 and IS: 15139-2002 respectively as and when notified separately under CMVR.

2.1.9 Sleeper berth

2.1.9.1 The sleeper berth (wherever provided) shall be located within the cab. No sleeper berth shall be permitted in the cargo area.

2.1.9.2 The sleeper berth shall be so constructed as to provide minimum length of 1750 mm measured along the longitudinal median axis of the berth. Figure - 2 of the section may be referred.

- 2.1.9.3 The sleeper berth shall have minimum width of 500 mm at least over the length of 1200 mm and 400 mm for the remainder. (Refer K in Figure -2).
- 2.1.9.4 The edges of the berth may be rounded to radii not exceeding 270 mm.
- 2.1.9.5 In case twin berth have been one above the other, the minimum pitch between the two berths (measured from top face of the lower berth with uncompressed cushion and lower face of the upper berth) shall be as follows (Refer J in Figure-2) –
- | | | |
|---|---|--------|
| In case the upper berth is folding type | - | 490 mm |
| In case the upper berth is fixed type | - | 770 mm |
- 2.1.9.6 The minimum distance between the roof and the upper berth, measured from top face of the berth with uncompressed cushion shall be 490 mm. Refer ‘I’ in Figure - 2.
- 2.1.10 Mudguards / Spray suppression devices:** The tyres of motor vehicles shall be enveloped with effective mudguards. The mudguards may be mounted on cab floor or sides or any part of the chassis frame. In addition, the vehicles shall be fitted with spray suppression devices in accordance with AIS-013, relevant for the categories of vehicles specified therein.
- 2.1.11 Driver’s work area**
- 2.1.11.1 **Reference system for dimensions:** The intersection point (co-ordinate origin) of all the three planes corresponds to the vehicle projected at the heel point of the accelerator pedal. Figure 1 may be referred.
- 2.1.11.2 **Heel point:** Heel point shall be located at a minimum distance of 300 mm from the inner face of the bulkhead. (Refer ‘Z’ in Figure-2)
- 2.1.11.3 **Reference point:** The “H” Point (Reference Point) shall be specified by the chassis manufacturer. The minimum distance of driver partition from the driver seat shall be 15 mm from the rearmost point of the driver seat in its rearmost position with seat back reclined backwards to an angle of 12 degrees. The minimum distance from H – point to roof top measured along the backrest at 12 degree angle shall be 900 mm.(Refer ‘Y’ in Figure-2(a))
- 2.1.12 Steering wheel:** The chassis manufacturer shall specify the position of the steering wheel with reference to the heel point. An adjustment range of minimum 60 mm shall be provided for the thigh clearance (i.e. the vertical distance measured between the top of seat cushion and bottom of the steering wheel – Refer ‘W’ in Figure - 2). This may be provided by way of adjustment in Seat Position or Steering Wheel position or combination of both. A minimum thigh clearance of 170mm shall be achievable in the adjustment range provided. The minimum distance of lower end of steering wheel from driver seat back shall be 265 mm. (Refer ‘N’ in Figure - 2)

- 2.1.13 Placement of instrument panel:** The placement of instrument panel shall be such that the primary instruments and controls are visible unobstructed while viewed from the driver seat. A view of driver information layout is shown in Figure- 4 for reference. The instrument panel shall be non-metallic, fire resistant, energy absorbing material and so constructed that in the event of a collision it shall cause minimum injury to the driver.
- 2.1.14 Position of controls :** The position of the controls such as accelerator, clutch, gear lever, service brake, parking brake etc. shall be specified by the vehicle manufacturer and should not be altered by the body builder.
- 2.1.15 Stowage Space :** Storage space, for keeping driver/ co-passenger personal belongings and utility items like tarpaulin, manila rope, assorted tools etc. may be provided in any part of the vehicle or load body. A safe box / cash box may be provided within the cab area for keeping cash and other vehicle related documents. Space for tools and emergency repair items / spare parts may be provided within the Cab.
- 2.1.16 First aid box:** First Aid kit containing items notified under Rule 138(4) (d) of Central Motor Vehicle Rules, 1989 shall be provided in the truck cab.
- 2.1.17 Heating, cooling and ventilation for driver:** The driver's work area shall be provided with blowers / ventilators or other suitable devices to ensure proper climate control. The guidelines specified in AIS-056, may be referred for this purpose.
- 2.2 Truck Cab – Technical and safety requirements**
- 2.2.1 Truck cab structural strength:** The truck cab shall meet the requirement of survival space as per AIS-029 as amended from time to time. In the case of non-OE built cabs, local body builders shall use type approved cab designs and / or parts only.
- 2.2.2 Front under - run protective devices (FUPD):** The front under-run protective devices fitted on the vehicles shall be in accordance with AIS-069 as amended from time to time and as notified under Central Motor Vehicle Rules, 1989.
- 2.2.3 Cab mounting arrangement and strength requirements:** The mounting arrangement for cab shall ensure adequate rigidity of cab with chassis against lateral / transverse movement of cab in case of braking or sudden acceleration or while driving on slopes. Mountings shall be:
- Made of round holes and suitable bolts with the least possible play, at least at the foremost and rearmost attachment points. Self locking fasteners may be used to prevent loosening due to vibrations. The fasteners used must be of suitable strength and shall ensure safety of cab against vibrations due to road irregularities.

- Of shock and vibration dampening type. The joint between the cab and chassis frame shall be provided with rubber cushions or any suitable arrangement.

2.2.3.1 **Fixed cabs:** The cab mountings shall be supported with rubber cushions and/or leaf spring with adequate lateral and longitudinal stiffness. When “U” bolts are employed to secure the cab to the chassis frame, spacers / stiffeners shall be used between the flanges of side-members to prevent buckling.

2.2.3.2 **Tiltable cabs - Tilting mechanism, locking requirements:** Suitable locking arrangement shall be provided to hold the cab in the tilted condition either automatically or by means of a retaining device. The provision shall have stopper along with locking arrangement, which can be disengaged with manual intervention only. The stopper shall be able to hold the weight of loaded cab with adequate safety margin. In case where the effort required to lift the cab is high, suitable arrangements shall be provided to assist the lifting. Additional assistance may be provided through hydraulic or mechanical means or any such suitable arrangement. In the case of locally built cabs, OE approved designs and parts shall be used or else the locally developed designs shall be type approved by the authorised agency. Vehicle manufacturer shall provide details of recommended practices for cab mounting including list of approved parts. In any of these cases, no part of chassis shall be altered so as to affect its stability or any other safety aspects including wiring harness, brake circuits etc.

2.2.4 Protection of occupants in the event of lateral collision

2.2.4.1 **Doors:** The doors shall be hinged at “A” Pillar. The door hinges, in case of hinged doors and locking mechanism shall be type approved by authorised agencies. External projections of doors shall comply with CMVR requirements. Door shall be fitted with weather resistant rubber material like EPDM rubber seals of suitable design to avoid dust and water ingress.

2.2.4.2 **Vehicle seats - design and strength requirements:** All seat designs and seat anchorage designs shall meet the requirements of standard AIS-023 as amended from time to time. All seat designs shall be type approved as per AIS-023. No part of the seat or seat anchorage shall be altered by the local body builder, whenever cabs are made outside the control of the vehicle manufacturer.

2.2.4.3 **Cab construction material:** Wood shall not be permitted to be used in the cab construction until and unless no other suitable material is available. Composite materials that meet the functional requirements may be used.

2.2.4.4 **Panels (exterior and interior):** The exterior and interior panel surfaces of cab shall be protected against corrosion. If suitable material is not available then the surfaces shall be coated with corrosion preventing paint.

- 2.2.4.5 **Roof luggage carrier:** No luggage shall be permitted to be carried on the roof of the cab. If any provision is to be made, the mounting of the same shall not be provided on the cab. If, for any reason the luggage carrier is made on cab roof, it shall not rest on the roof. It shall be supported on channels that get linked to the “A” and “B” pillars. Any such structure shall meet the following strength requirements.
- Uniformly distributed static load of 150 kgf / m².
 - Inertia forces equivalent of 2.5 g.
 - Shear force equivalent to 1.5 g.
- Further, the maximum load capacity of such a stowage space shall be specified on a plate fitted outside the stowage space. At any point of time, load shall not be transferred to the cab.
- 2.2.5 **Lighting and signaling devices:** The lighting and signaling devices on the truck cab shall meet the requirements specified in AIS-008 and as amended from time to time. Only type approved parts or recommended parts and Installation shall be used when the cab is made by local body builders.
- 2.2.6 **Rear view mirrors:** The rear view mirrors shall be provided and shall meet the requirements specified in AIS-001 and AIS-002 as amended from time to time.
- 2.2.6.1 **Interior rear view mirror:** The location, make, type and size of the interior rear view mirror, if fitted, shall be the one which is approved by the test agency.
- 2.2.7 **Driver’s work area:** No part of the vehicle’s fixed components shall intrude into the Driver’s Work Area.
- 2.2.8 **Door locks and hinges:** Door components such as door locks and hinges shall meet the requirements specified in IS: 14225-1995, under Rule 124 of the Central Motor Vehicles Rules, 1989, as amended from time to time.
- 2.2.9 **Window**
- 2.2.9.1 **Window type:** Cab windows on doors shall be of winding type. Other windows may be sliding type, fixed type or with partial opening type.
- 2.2.9.2 **Window glass:** The window glass shall be made of safety glass as specified in IS: 2553 (Part 2) and shall readily break on impact (such as a stroke of a hammer) in the event of an accident.
- 2.2.9.3 **Thickness of glass:** The minimum glass thickness shall be 3.5 mm for windows.
- 2.2.9.4 **Edges of glazing:** The edge shall be crown edge, satin finish for all the exposed edges that is likely to come in touch with the person’s body. This edge specification corresponds to Edge No. 1 specified in SAE J673.

- 2.2.9.5 **Window frames for other than door windows:** The glazing may be mounted on frame; constructed from aluminum extrusions or formed steel / coated sections. Alternately directly, sliding on flocked rubber channels supported by aluminum/steel section. The window frames shall be mounted such that distortions and change of aperture dimensions due to forces on the structure does not deform the guide way. The window glass/glass and frame shall slide smoothly when subjected to normal pull force (50 to 75N).
- 2.2.10 **Ingress of dust and rain water :** All doors, windows and hatches should be so constructed such that it does not permit ingress of rain water, in the fully closed condition. It is recommended that the Truck body builders carry out their own internal assessment test to check water proofing as per IS: 11865–1992. All doors, windows and hatches should be so constructed such that it does not permit ingress of dust, in the fully closed condition. It is recommended that the Truck body builders carry out their own internal assessment test to check dust ingress as per IS: 11739-1997. Drain holes shall be provided in the window frame such that water shall flow outward and does not flow into the structure cavity or into the passenger compartment.
- 2.2.11 **Wind screen and wind screen wiping system:** Wind Screen to be made of laminated glass meeting the requirements stated in Indian Standard IS: 2553-1992. Wind screen must be provided with windscreen washing and wiping system. The wind screen wiping system shall meet the requirements specified in IS: 15802-2008 as amended from time to time.
- 2.2.12 **Fire extinguishers:** Provision of at least one fire extinguisher shall be made for all kind of trucks. Special provisions should be made for the trucks carrying explosive materials. Halogenated hydrocarbon type of extinguisher shall not be used as extinguishant. The fire extinguishers shall be secured against tampering and shall be easily accessible to incumbent. Also the location shall be marked clearly.
- 2.2.13 **Guidelines for corrosion protection:** The quality of the surface treatment shall be tested according to the test methods specified in JIS: D0202 or any equivalent Indian / International standards. The minimum quality requirements in table below may be met for test criteria specified in Para. 4 of JIS D0202.

Item		Quality
Surface Condition –Appearance		There must be no surface roughness, pin holes or other harmful defects.
Corrosion Resistance	Iron Phosphate treatment	72 (Hrs)
	Zinc Phosphate treatment	96 (Hrs)
Water and moisture	Iron Phosphate treatment	36 (Hrs)

Resistance	Zinc Phosphate treatment	48 (Hrs)		
Oil Resistance (40 Deg. 24 hrs)h		No swelling, flaking, peeling, cracking, film softening nor appreciable change in lustre or colour		
Volatile Oil Resistance (Gasoline) (24 hrs)		No swelling, flaking, peeling, cracking, film softening nor appreciable change in lustre or colour		
Pencil Scratch Test		Shall resist HB or Harder		
Checker Mark : No of sections in which film remains intact (without peeling off) Grade 3 shall apply only to Copper and copper alloy bases, Aluminum and aluminum alloy bases and Zinc and Zinc alloy bases		Grade 1	Grade 2	Grade 3
		100	90 or more	60 or more

REFERENCE SYSTEM FOR DIMENSIONS

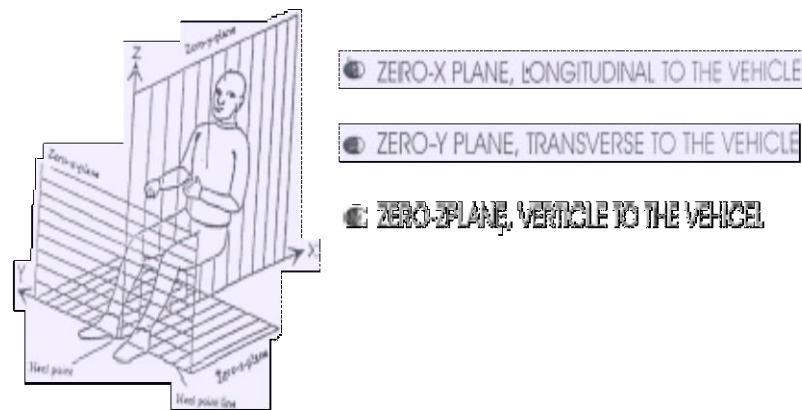

Figure - 1
Reference System for Dimensions

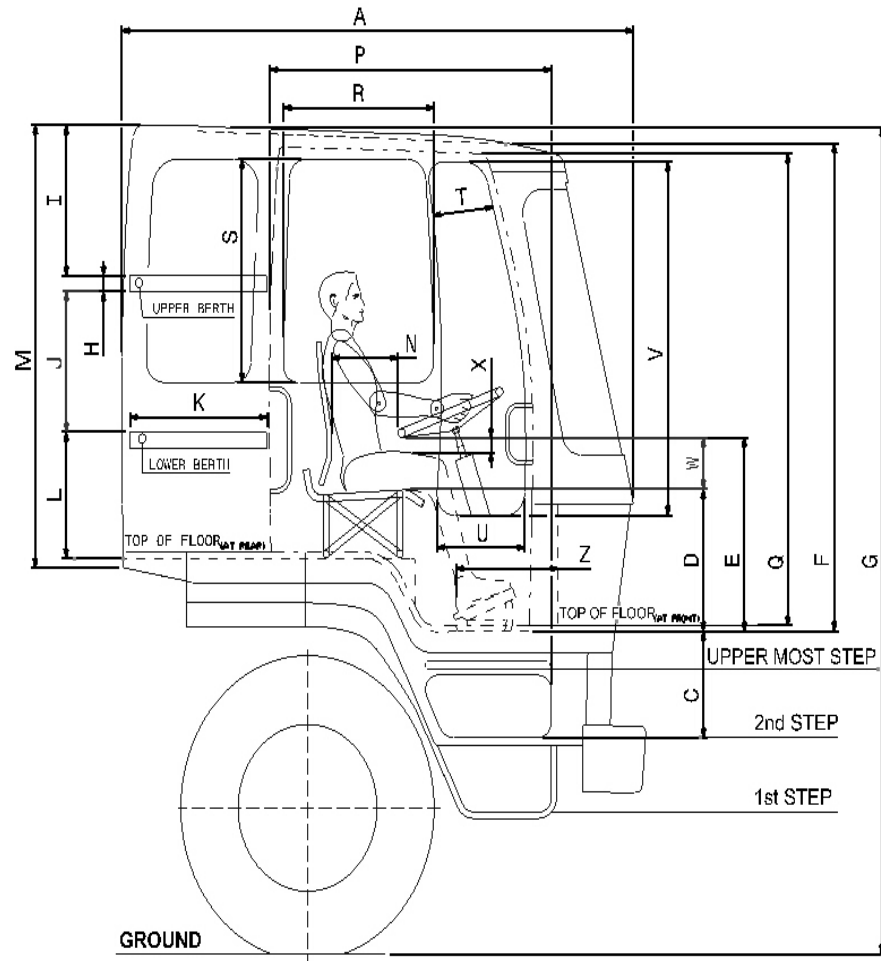
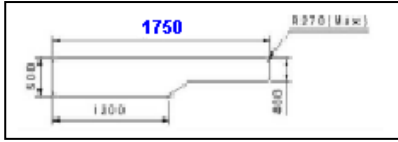

Figure - 2
Driver’s Work Area and Sleeper Berth requirements in Vehicle Unladen Condition
 (Refer Annexure-I, clause 17.0 and the Table on next page.)

Driver Work and sleeper Berth Requirements (In Unladen Condition)			
Sl. No.	Details of CAB specifications	Symbol	Value on-road vehicles
1	Overall Length of the CAB, mm	A	*
2	Height of floor from top of 2 nd Foot Step	C	
3	Distance from Top of Floor to the Top of cushion of driver’s seat ,mm (Cushion Uncompressed)	D	
4	Distance from Top of the floor to the bottom of the steering wheel, mm	E	
5	Distance from Top of the floor to the Roof Inner, mm	F	

6	Height of the CAB from ground, mm	G	
7	Thickness of the berth, mm	H	
8	Distance between the top of Upper Berth cushion to Roof Inner, mm (Min)	I	490 mm
9	Distance between top of lower berth (cushion uncompressed) to bottom of upper berth (Min)	J	490 mm
10	Berth width 	K	400-500 (500 for at least 1200 length)
11	Height of Lower berth from top of floor at rear, mm (Cushion Uncompressed)	L	*
12	Height of CAB at rear, mm	M	
13	Distance between Back rest of driver seat (At Maximum Thickness) to edge of steering wheel	N	265 Min
14	Width of the door (Min)	P	800
15	Height of the door, mm (Min)	Q	1050
16	Width of Window, mm (Min)	R	450
17	Height of Window, mm (Min)	S	400
18	Width of observation window (On door) at top, mm	T	
19	Width of observation window (On door) at bottom, mm	U	*
20	Height of observation Glass, mm	V	
21	Minimum length of the sleeper berth measured along the longitudinal median axis of the berth (Left to Right)	----	1750
22	Minimum distance from H point to roof measured along the back rest at 12 degree angle, mm (head room)	Y	900 mm (min)
23	Thigh clearance for the driver - The vertical distance measured from top of the seat cushion of driver's seat to the bottom of steering wheel, mm	W (E-D)	170(min) (considering adjustment range of min 60 mm)

24	Heel point - Minimum distance from inner face of bulk head, mm	Z	300
25	Adjustment range for the thigh clearance, mm	X	60 (min)
*Note: These dimensions are design specific varies with manufacturer			

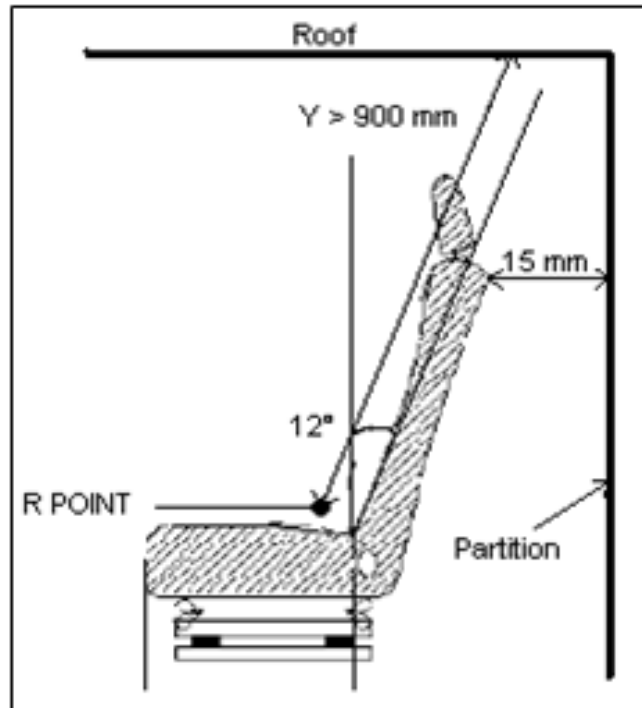

Figure- 2(a)

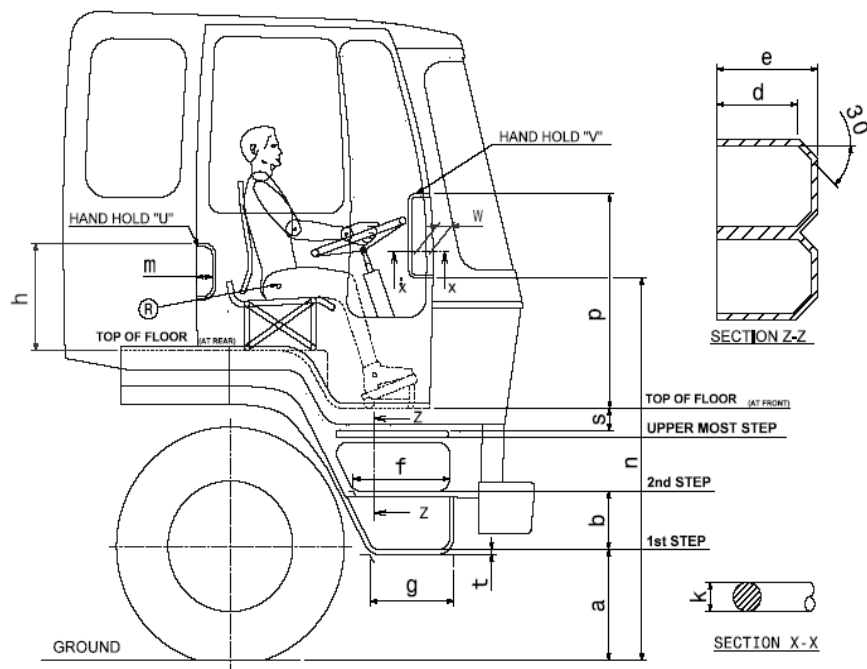

Figure 3

Guidelines on climb facility and hand holds (in unladen condition)				
S. No	Description	Symbol	Value for on-road vehicles	Value for off-road vehicles
1	Maximum height from ground to surface of first step, mm	a	550	700
2	Maximum vertical distance between top surface of subsequent steps, mm	b	400	500
3	Minimum step depth, mm	d	80	80
4	Minimum step clearance including step depth, mm	e	150	150
5	Minimum step width (other than first step) , mm	f	200	200
6	Minimum step width for lower step, mm	g	100
7	Reference point specified by chassis manufacturer (SGRP) , mm	r
8	Cross section of handle, mm	k	20 Min and 38 Max	
9	Hand clearance to the mounting surface (i.e, the gap for inserting palm) for grab handle on "B pillar", mm	m	30 Min	30 Min
10	Hand clearance to the mounting surface (i.e, the gap for inserting palm) for grab handle on "A pillar", mm	w	30 Min	30 Min
11	First hand hold/ hand rail height from ground level (max) , mm	n	1850	1950
12	Minimum thickness of the foot step, mm	t	20	20
13	Minimum height of the upper most step to floor, mm	s	120	120

1ST GENERATION
DRIVER INFORMATION MANAGEMENT SYSTEM

FREE AIR FLOW

FREE AIR FLOW

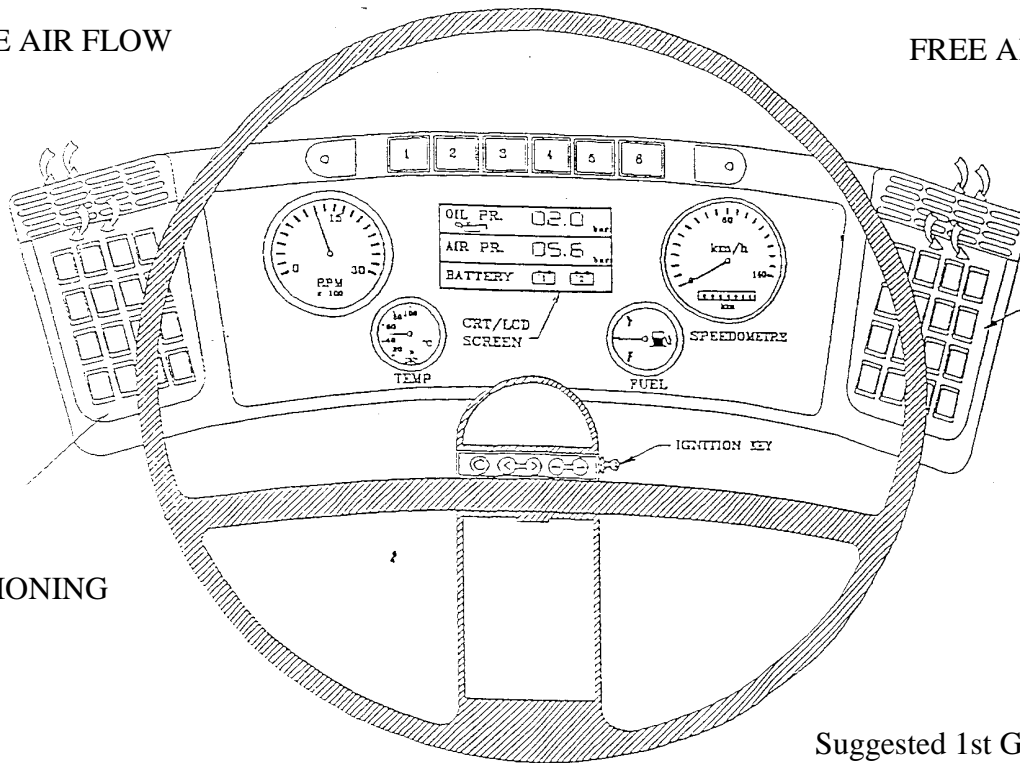

SPACE FOR
CHASSIS &
AIR CONDITIONING
SWITCHES

1. LOW PRESSURE, RED
2. EXHAUST BRAKE ON, RED
3. PARKING BRAKE, RED
4. DRAIN FUEL WATER SEPARATOR, AMBER
5. HAZARD WARNING
6. ANY OTHER REQUIRED AS PER APPLICATION

Figure-4

Suggested 1st Generation Practices

No. of Gauges: 04

No. of Indicators: 06

No. of Switches: AS REQUIRED

For chassis, internal
/external lighting
and A.C. controls.

SECTION - 3.0
TRUCK LOAD BODY –
GENERAL, TECHNICAL AND SAFETY REQUIREMENTS
LIST OF CONTENTS

3.1	Categorisation of Truck Load Bodies
3.2	General Requirements
3.2.1	Overall Dimensions
3.2.2	Cab and Body gap
3.2.3	Stowage Space/ Luggage Carrier
3.2.4	Mudguards / Spray Suppression Devices
3.2.5	Rope Hooks and other Provisions
3.3	Technical Requirements
3.3.1	Working Stability
3.3.2	Mounting of the Body or Load Platform of Commercial Vehicles
3.3.3	Body Construction requirements
3.4	Safety Requirements
3.4.1	Protection of the Occupants of Goods-carrying Power-driven Vehicles against the Shifting of Loads
3.4.2	Securing the Load on the Load body
3.4.3	External Projection
3.4.4	Lighting and Signaling devices
3.4.5	Retro-Reflective Markings for Heavy and Long Vehicles
3.4.6	Lateral Protective device
3.4.7	Rear Under run Protective Device (RUPD)
3.4.8	Modification of Chassis and / or Chassis related Components
3.4.9	Guidelines for Corrosion Protection
3.4.10	Closed Type Load Bodies

3.1 **Categorization of truck load bodies**

The trucks are categorized on the basis of design namely rigid axle vehicles and tractor trailer combination. Trucks are further sub-categorized on the basis of truck body construction like the following.

HSD – High Side Deck body

FSD – Fixed Side Deck or Half body

DSD – Drop Side Deck body

FB – Flat Bed or Fully open body

CLB – Closed Body

ALC – Aluminium Container

STC – Steel container

SPB – Special Purpose Body including tippers & dump trucks

3.2 **General requirements**

3.2.1 **Overall dimensions**

The overall dimensions of the load body shall comply with the provisions laid down in Rule 93 of the Central Motor Vehicle Rules, 1989 as amended from time to time.

3.2.2 **Cab and body gap**

Clearances / gaps as recommended by vehicle manufacturer should be ensured in respect of tyre, wheel arch, fuel / oil checking and filling, cab (where applicable). In the case of separate cab and load body, the body shall be separated from cab by at-least 50mm behind as shown in Figure-4. The gap may be covered with gap seal for better aerodynamics.

3.2.3 **Stowage space / luggage carrier**

Stowage space for keeping utility items like tarpaulin, manila rope, assorted tools etc. may be provided in any part of the vehicle or load body. If the same is provided over the load body, it shall meet the following requirements

- Uniformly distributed static load of 150 kg/m^2
- Inertia forces equivalent of 2.5 g.
- Shear force equivalent to 1.5g.

Further, the maximum load capacity of such a stowage space shall be specified on a plate fitted outside the stowage space.

3.2.4 **Mudguards / Spray suppression devices**

The tyres of motor vehicles shall be enveloped with effective mudguards. The mudguards may be mounted on body floor or any part of the chassis frame. Non-rigid flap (metallic or non-metallic)

shall be provided at rear of mudguards to prevent splashing of water, dust or muck over the vehicles coming from behind. In addition, the vehicles shall be fitted with spray suppression devices in accordance with AIS-013, relevant for the categories of vehicles specified therein.

3.2.5 Rope hooks and other provisions

The load bodies shall be so constructed to allow use of covers, wherever required. Rope hooks or any such feature may be provided on sides, front, rear or base of the load body to facilitate spreading and fastening of covers over the body. Sufficient space must be provided on sides of body to depict vehicle related details as specified by National or State Transport Rules.

3.3 Technical requirements

3.3.1 Working stability: The vehicles meant for carrying dangerous and / or hazardous goods shall meet the working stability requirements stated in Section -8 of this Code.

3.3.2 Mounting of the body or load platform of commercial vehicles

3.3.2.1 The mounting arrangement for load body shall ensure adequate rigidity of body with the chassis.

3.3.2.2 The mountings shall ensure adequate resistance against lateral / transverse movement of load body in case of braking or sudden acceleration or cornering or while driving on slopes. The recommendations of the OEM's shall be taken as guidelines.

3.3.2.3 For mountings, use shall be made of round holes and suitable bolts with the least possible play, at least at the foremost and rearmost attachment points.

3.3.2.4 Suitable compressible packing (such as rubberised ballatta duck, or wood) may be used between the chassis and body frame. Thickness of such packing shall be selected to ensure uniform load distribution over chassis frame even in case of minor waviness or twist in the chassis frame / sub-frame.

3.3.2.5 The sub-frame shall be mounted on chassis by means of attachment plates or out-rigger brackets or directly on chassis to prevent longitudinal movement of load body in case of braking and sudden acceleration as shown in Figure – 1. Wherever, the U-bolts are used for clamping (in addition to positive mountings as stated above), they shall be used in conjunction with stiffeners to prevent chassis frame from buckling, as shown in Figure – 2.

3.3.2.6 In case of load bodies not made by OEM or as per OEM designs, the mounting arrangement for the load body or platforms shall be as per recommendations provided by the vehicle manufacturers. Details of recommended practices for load body mounting including list of approved parts to be provided by vehicle manufacturer. OE

developed and type approved designs may be used by local body builders.

3.3.3 Body construction requirements

3.3.3.1 In constructing the body or load platform, all practicable steps shall be taken to keep the centre of gravity of the vehicle as low as possible.

3.3.3.2 The construction of the body or load platform shall be such as not to impair the soundness and functioning of the wiring and braking circuits.

3.3.3.3 The load body shall be constructed over a sub-frame to distribute the load evenly on the chassis frame and also to create gap between body and tyre / chassis for wheel articulation.

3.3.3.4 The material used for sub-frame construction shall be steel or aluminum alloy or any composite material with adequate strength to bear impact loads.

3.3.3.5 The sub-frame shall be angled, curved or forked in the front as shown in Figure-5.

3.3.3.6 The sub-frame shall be mounted on chassis by means of attachment plates or out-rigger brackets or directly on chassis to prevent longitudinal movement of load body in case of braking and sudden acceleration. The number and size of hardware used for attaching shall be determined by the payload carried on the vehicle. Self-locking or “Anti-vibration” hardware shall be used for fastening. Some other typical arrangements for mounting the sub-frame and the recommendatory guidelines are as shown in Figure - 6 to Figure -11.

3.3.3.7 The floor, head board (also called crash guard or front wall) and side walls are the main load bearing elements of the body. The floor shall be rigidly supported on the sub-frame. The section of floor and floor supports in the sub-frame shall be pitched / spaced to achieve distributed loads even in case of concentrated loads such as steel coils or fork lifts etc.

3.3.3.8 The side walls and crash guard shall be constructed to bear a part of load carried on the vehicle in case of braking, turning, travel on slopes etc. as given below, which can also be proved by FEM analysis.

- Side walls : 30 % of rated pay load carried
- Crash guard or head board : 40% of rated pay load carried, the maximum however being 5000 kgf
- Rear wall or tail gate : 25% of rated pay load carried

3.3.3.9 Where the cab and bodywork are integral, account shall be taken of

the flexibility of the cab mounting.

- 3.3.3.10 In the case of tank-vehicles, where outrigger brackets are used to fasten the tank to the chassis of the vehicle, the vertical face of the brackets shall not be less in height than the depth of the chassis frame to which they are attached.
- 3.3.3.11 In the case of tipping vehicles, where there is no supplementary under-frame, to distribute the load, the pivot brackets for rearward tipping bodies shall be located as near as possible to the rear spring brackets to minimize additional bending stresses on the chassis frame during tipping.
- 3.3.3.12 In the case of bodies tipping rearwards only, guide plates shall be provided to control the lateral movement of the body when lowered onto the chassis frame.
- 3.3.3.13 In the case of tipping bodies, steps shall be taken to prevent excessive noise caused by the bodywork of the vehicle when it is unladen.

3.4 Safety requirements

3.4.1 Protection of the occupants of goods-carrying power-driven vehicles against the shifting of loads

- 3.4.1.1 The equipment of vehicles shall be in conformity with provisions calculated to reduce the risks run by the driver and the other occupants of goods-carrying vehicles in the event of a forward shift of the load on sudden braking.
- 3.4.1.2 The occupants of such a vehicle shall be protected by a screen or headboard capable of withstanding without breaking, a uniformly distributed static force of 200 kgf per ton of the vehicle's permissible useful load. This load shall be applied by means of a rigid barrier perpendicular to the longitudinal median axis of the vehicle, covering at least the whole of the cab rear wall situated above the chassis frame, and moving parallel to that axis. This shall be in accordance with the requirements specified in AIS-029.
- 3.4.1.3 This protective screen or headboard may be detachable. It must meet the following requirements.
 - 3.4.1.3.1 It's width (measured at right angles to the longitudinal median axis of the vehicle) must be at least equal to the width of the space provided for the occupants and where there is a separate cab, at least equal to the width of the cab.
 - 3.4.1.3.2 In height, it must match at least 800 mm for N3 category vehicles and may be at least 800 mm for N2 category vehicles.
 - 3.4.1.3.3 It must be secured directly to the chassis or to the front of the loading platform.

- 3.4.1.3.4 If it is secured to the loading platform or, where appropriate, to the body, the anchorage of that platform to the chassis must be capable of withstanding the thrust transmitted.
- 3.4.1.3.5 In cases where the cab is integral with the body, the protective screen or headboard may be secured to, or form part of, the body structure.
- 3.4.1.3.6 Where a power-driven vehicle or a semi-trailer is designed to carry beams, pipes, girders, sheet metal or similar loads, the protective screen or headboard must have a resistance at least equal to that of steel plate not less than 3 mm thick.
- 3.4.1.3.7 Where a vehicle is equipped with a trestle or bolster behind the cab for the purpose of supporting long loads, such as steel girders or telegraphic poles, the trestle or bolster must be capable of withstanding the combined effect of two forces, each of 600 daN per ton of permissible load, acting forwards and downwards on the top of the trestle.
- 3.4.1.3.8 This rule shall not apply to tank-lorries and special-purpose vehicles for the carriage of containers, or to special-purpose vehicles for the carriage of indivisible objects, where the latter vehicles and their operation are subject to special regulations

3.4.2 Securing the load on the load body

The friction between the load body and the load is not sufficient to prevent movement of load in case of braking, sudden acceleration and during cornering. In fact higher the load, the greater are the chances of shifting of load. It is therefore essential to provide positive lashing of goods being carried in the load body. The body manufacturer shall provide provision for lashing by means of ropes, chains etc.

The rope hooks provided below the loading platform shall be considered as anchorage for lashing provided the same are type approved to carry a load of at-least 500 kg. Each anchorage on the body and hook provided on rope / chain for lashing shall be designed and marked to carry a specified load. The lashing points should comply with British Standard BS-EN-12640:2001 or any other equivalent Indian or International standard. The number of hooks to be used shall be determined by the load to be carried and the capacity of the hook. Typical configurations for lashing of goods are shown in Figure - 3.

3.4.3 External projection

The external projection of the load body shall meet the requirements of IS :13942 as amended from time to time as specified at Sl. No. 11 of Table under Rule 124 of the Central Motor Vehicles Rules, 1989.

3.4.4 Lighting and signaling devices

The Lighting and signaling devices if provided on the load body shall meet the requirements of AIS-008 as amended from time to time. Only type approved parts or recommended parts shall be used.

3.4.5 Retro reflective markings for heavy and long vehicles

Retro-reflectors and side marker lamps shall be provided as per the requirements stated in AIS-008, as amended from time to time. For heavy and long vehicles, the reflective markings shall meet the requirements stated in AIS-089 or AIS-090 as applicable, amended from time to time and as notified under Central Motor Vehicle Rules, 1989.

3.4.6 Lateral protective device

The lateral protective device shall be as per requirements of IS: 14682, as amended from time to time. The device may be mounted on the load body or the chassis. No other vehicular safety part or the system shall be attached to the lateral protection device. In case of locally built bodies recommended installations and parts shall be used. Recommended installation details and parts shall be supplied by the vehicle manufacturer. Vehicle manufacturer may provide detailed part drawings (including material specifications) of the approved parts for fabrication by the local body builder.

3.4.7 Rear Under-run Protective Device (RUPD)

The rear under-run protection device shall meet the requirements of IS:14812. as amended from time to time. Vehicle manufacturer shall provide the RUPD as integral part of the fully built-up vehicle. In case of drive-away chassis or incomplete vehicles the RUPD shall be provided by vehicle manufacturer. The local body builder shall not alter the fitment of the rear under-run device at any point of time.

3.4.8 Modification of chassis and / or chassis related components

Unauthorized alterations shall not be permitted on the chassis or any of its aggregates or components. No part of the braking system, electrical system, steering system or suspension system shall be altered, when the body is made outside the vehicle manufacturer facilities. No part of chassis shall be altered which affects the stability of the vehicle. Any unauthorised modification shall call for fresh type approval of the design and the prototypes.

3.4.9 Guidelines for Corrosion protection

The quality of the surface treatment shall be tested according to the test methods specified in JIS D0202 or equivalent Indian / International standard (General rules of coating films for automotive parts or equivalent standards). The minimum quality requirements in

table below shall be met for test criteria specified in Para. 4 of JIS D0202.

3.4.10 Closed type load bodies

All the sides of the load bodies should be preferably of the closed type, except the Special Purpose Bodies viz., tippers and dumpers. Typical closed body types are as shown in Figure - 12.

Item		Quality		
Surface Condition – Appearance		There must be no surface roughness, pin holes or other harmful defects.		
Corrosion Resistance	Iron Phosphate treatment	72 (Hrs)		
	Zinc Phosphate treatment	96 (Hrs)		
Water and moisture Resistance	Iron Phosphate treatment	36 (Hrs)		
	Zinc Phosphate treatment	48 (Hrs)		
Oil Resistance (40 Deg. 24 hrs)h		No swelling, flaking, peeling, cracking, film softening nor appreciable change in lustre or colour		
Volatile Oil Resistance (Gasoline) (24 hrs)		No swelling, flaking, peeling, cracking, film softening nor appreciable change in lustre or colour		
Pencil Scratch Test		Shall resist HB or Harder		
Checker Mark : No of sections in which film remains intact (without		Grade 1	Grade 2	Grade 3

peeling off) Grade 3 shall apply only to Copper and copper alloy bases, Aluminum and aluminum alloy bases and Zinc and Zinc alloy bases	100	90 or more	60 or more
--	-----	------------	------------

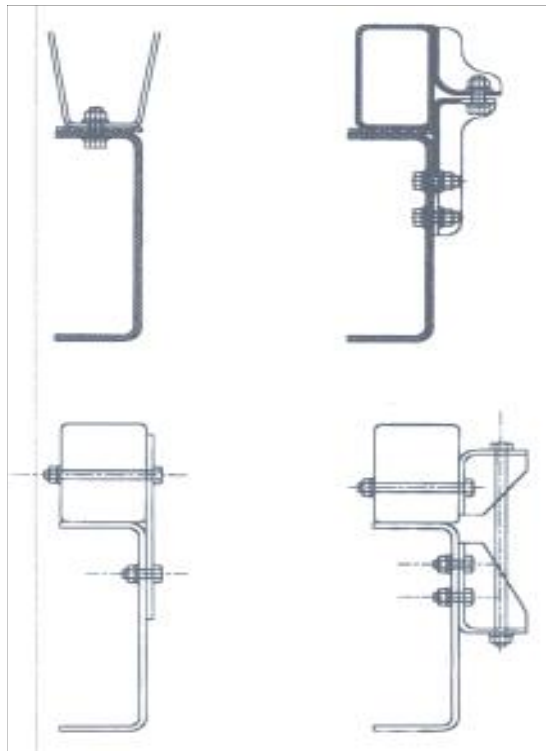

Figure -1
Chassis and Body Frame Mounting

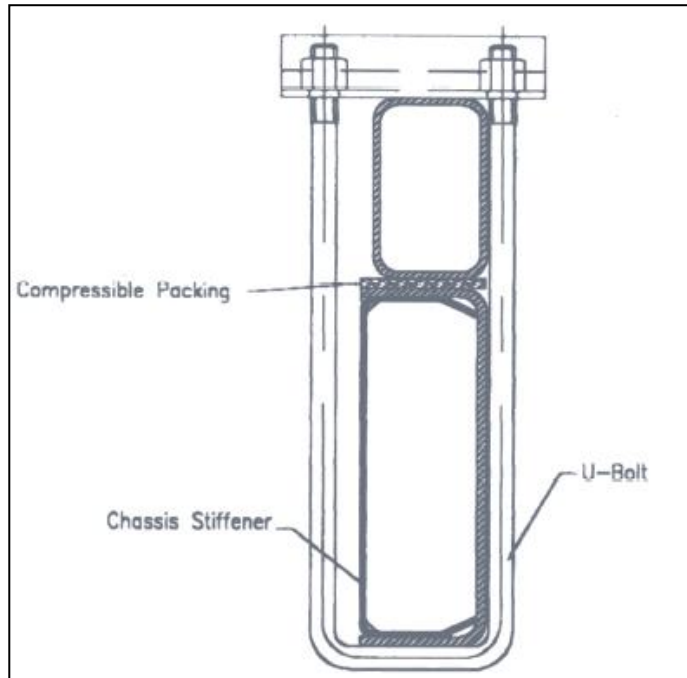

Figure - 2
Typical Load Body Mounting using U-Bolts

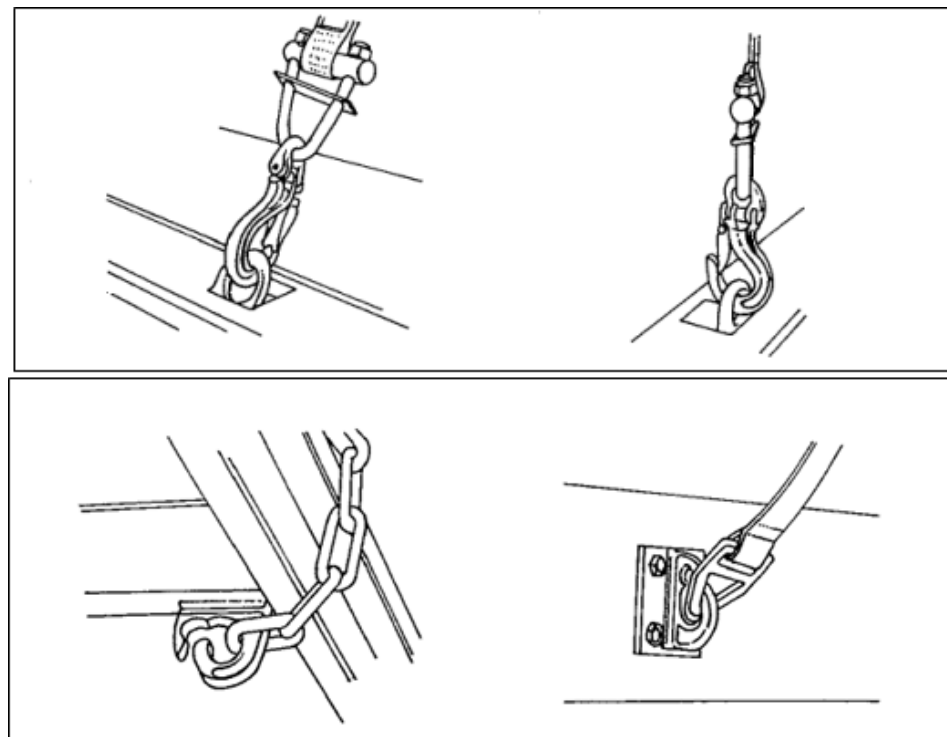

Figure - 3
Typical Hook Configuration for Lashing of Goods

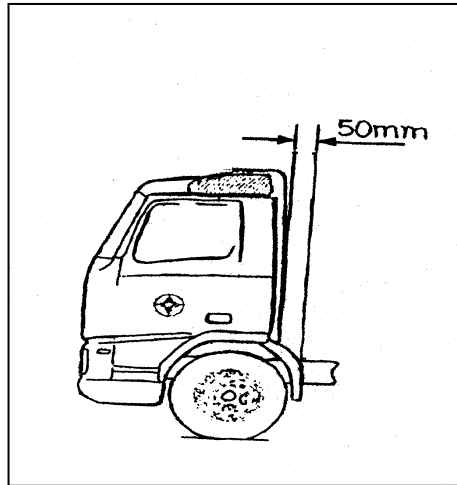

Figure – 4
Cabin and Body Gap

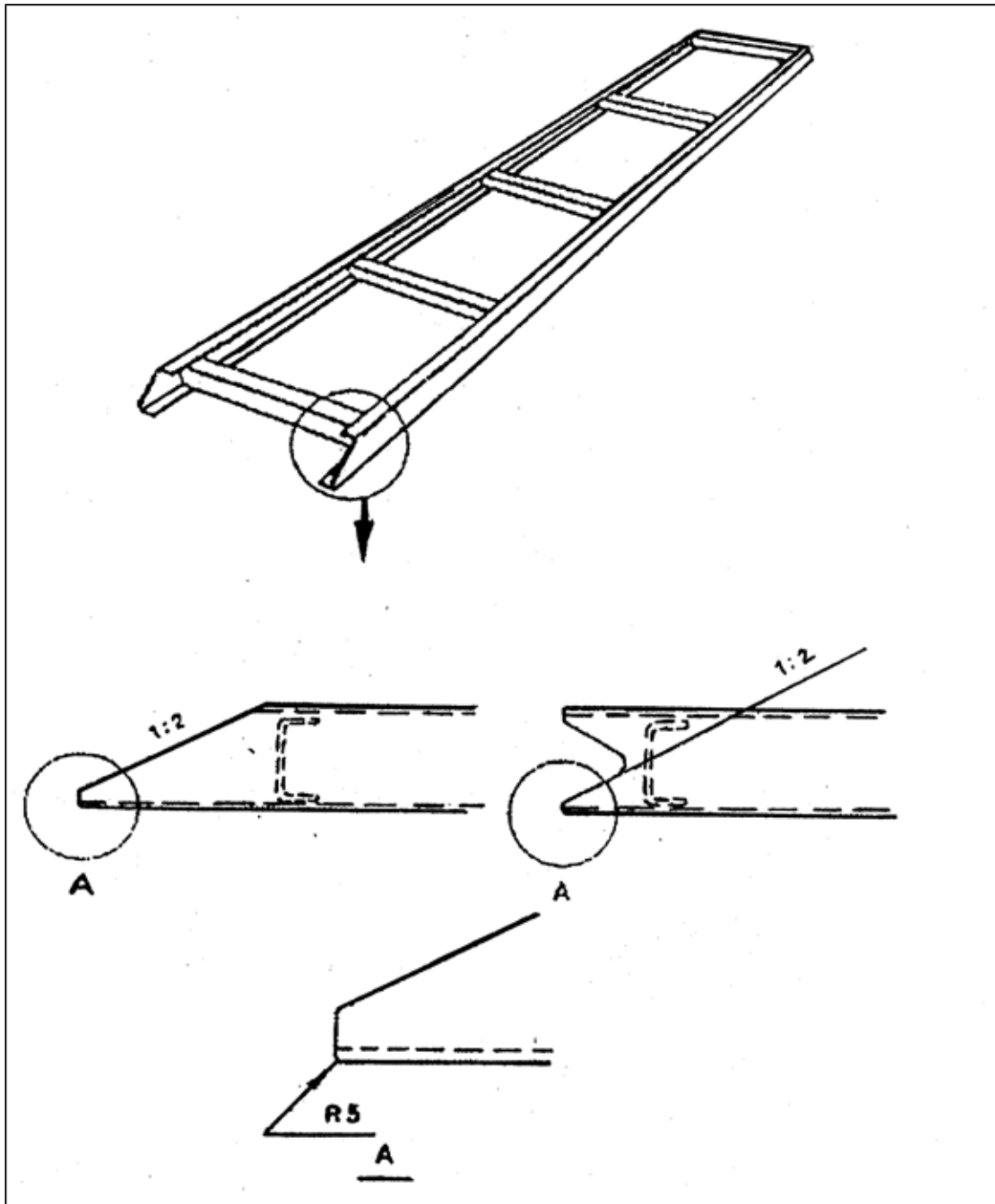

Figure - 5

Front End Configuration of Sub-Frame

Subframe

General

The subframe is the marriage point between the bodywork and the chassis.

- A part of the bodywork
- Adapted attachments
- Mounting

The subframe itself has low strength requirements and must therefore have flexible attachments at the front. Torsion sensitive bodywork also require a suitable body-front design.

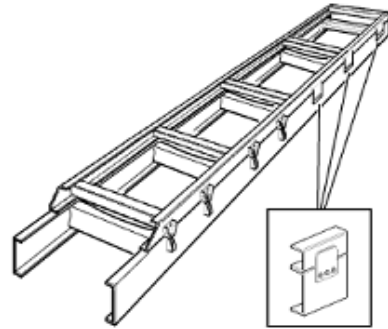

T9007477

A part of the bodywork

The subframe distributes the load on the chassis and gives sufficient strength to the bodywork. The subframe is part of the bodywork and does not reinforce the chassis.

Adapted attachments

Depending on the bodywork and driving conditions, the front section of the subframe is secured to the chassis by means of various kinds of jointed fasteners (pivoted, one way flexible etc.) The rear part of the subframe is secured by attachment plates.

Mounting

The attachments and the attachment plates are fixed to the chassis using M14 bolts. The attachments or attachment plates are bolted or welded to the subframe.

Figure - 6
Mounting of Sub-frame

Body attachments, general

The lower front body attachments from the factory will be selected as a function of body stiffness and driving conditions. Five types of attachments are used for securing bodywork:

- Pivoted (two types)
- Flexible one-way
- Elastic one-way
- Elastic two-way

The flexible one-way attachment is a pivoted joint using diaphragm springs. The elastic one-way is a pivoted attachment with a coil spring.

Pivoted	Pivoted	Elastic one-way
		
Elastic two-way	Standard attachment plate (Welded)	Medium attachment plate (Stronger, bolted)
		
Standard attachment plate (Bolted)	Strong attachment plate (Reinforced, plug-welded)	Medium attachment plate (Stronger, plug-welded)
		

Figure-7
Body attachments

Distance between attachment units

Below is the recommended distance between hole groups, depending on the vehicle's attachment unit.

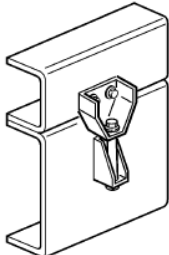
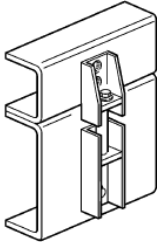
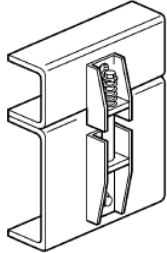
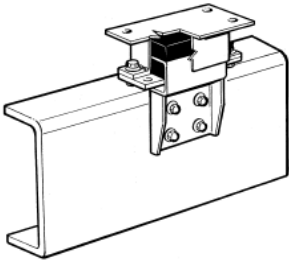
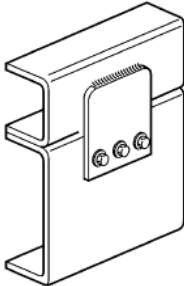
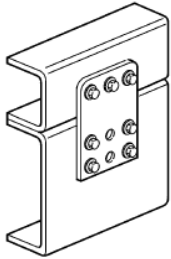
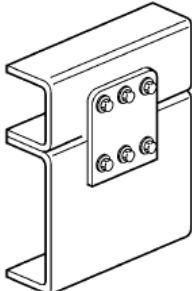
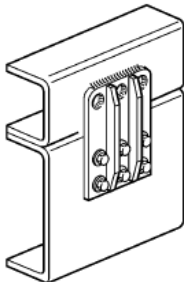
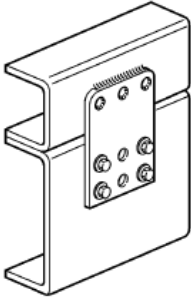
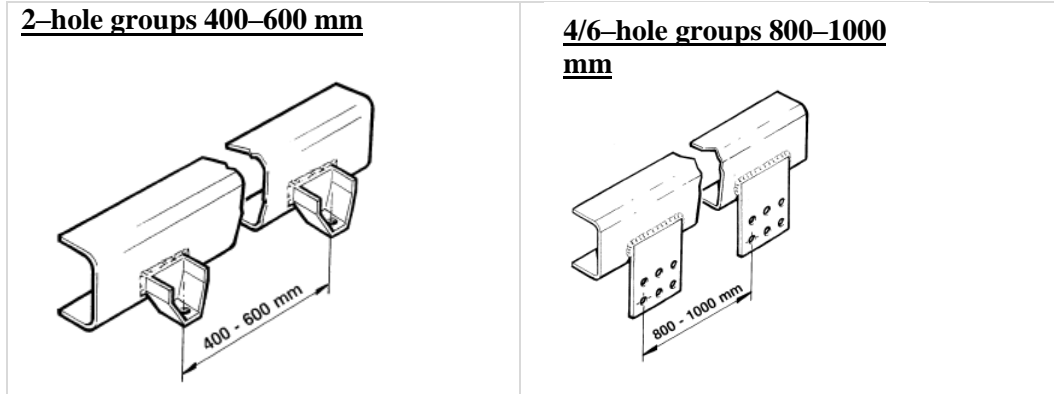

Upper part of attachment

The upper part of the pivoted attachments should be fitted to the sub frame so that the lower edge overlaps the chassis frame by:

- 30 ± 1 mm for frames with a height of 300 mm (see illustration).
- 23 ± 1 mm for frames with a height of 266 mm.

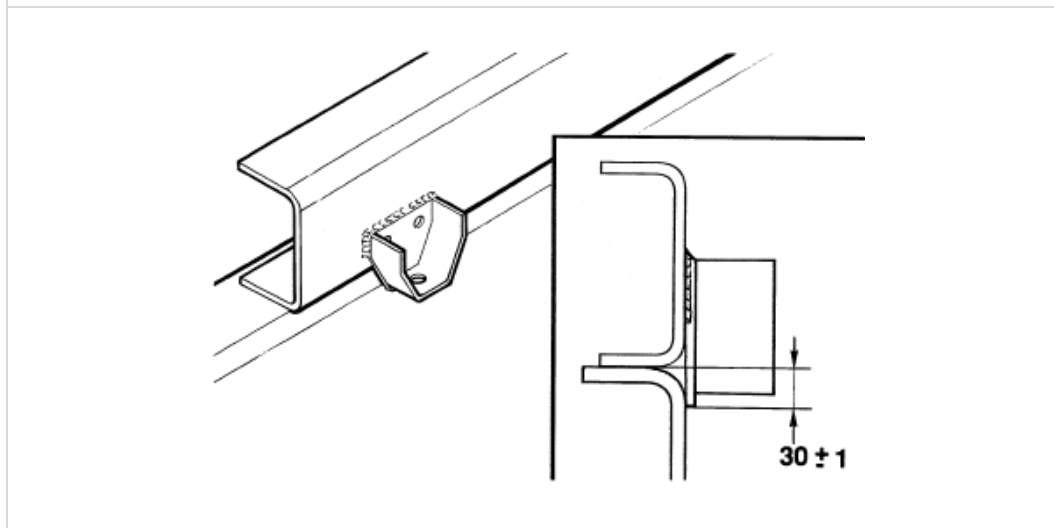

Figure - 8

Distance between Attachment Units

Elastic two-way attachment

The best way to allow upward and downward movements of torsionally stiff structures is to use the two rubber cushions. This is essential as a tank structure has an exceptional torsional rigidity and therefore has great difficulty in following the chassis as it flexes and twists. It may be recommended that each attachment allows a vertical movement of the chassis frame of at least:

- 5 mm upwards, suitable rubber hardness 70 shore.
- 15 mm downwards, suitable rubber hardness 45 shore.
- Suitable type of rubber EPDM.

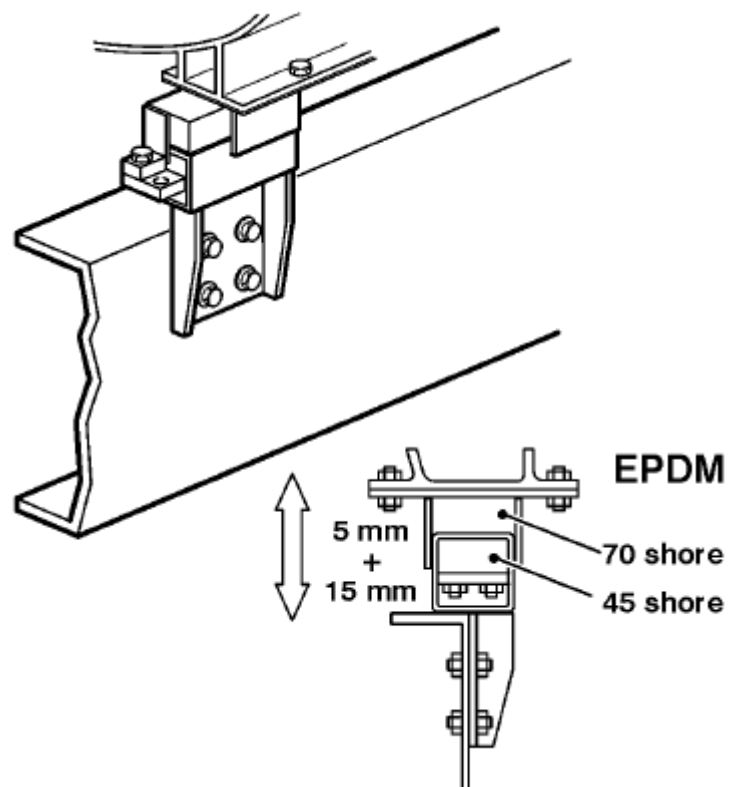
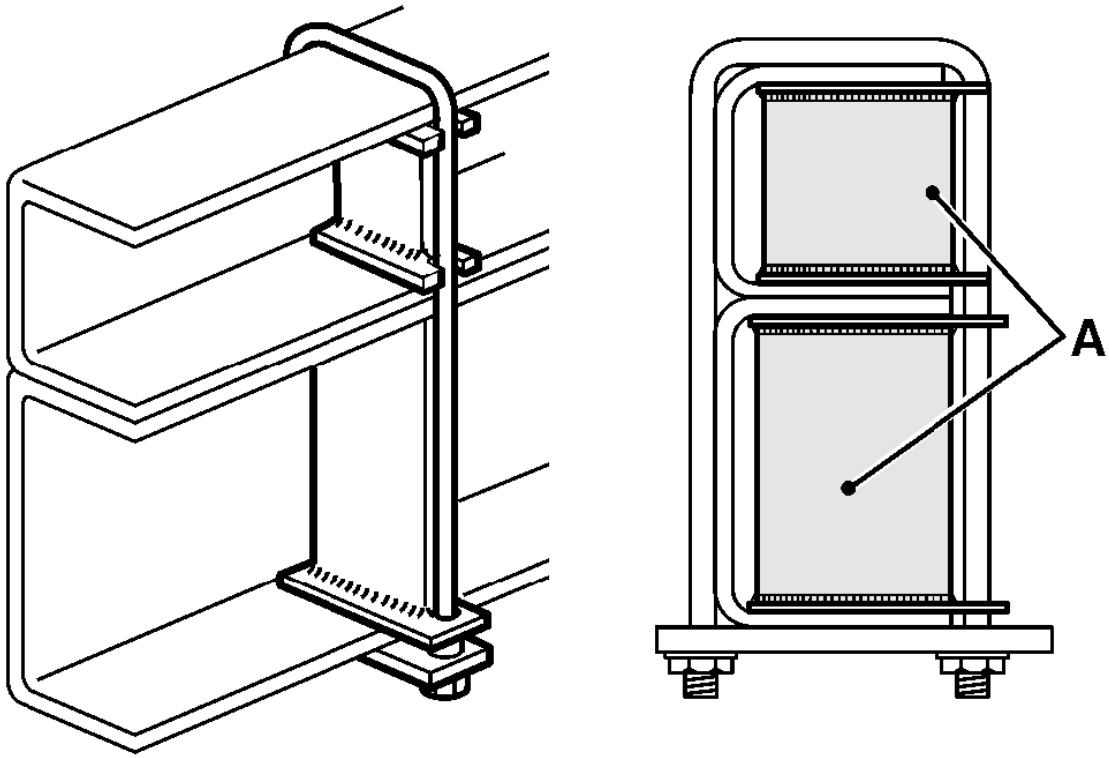

Figure – 9
Elastic Two-way Attachment

Clamps can place high bending forces in the chassis flanges. Spacers (A) **must always** be fitted between the chassis/sub/helper-frame flanges, if clamps are used.



Recommended attachments Bodywork must be secured so that the complete vehicle:

- has good driving characteristics.
- has sufficient stability and strength.
- is capable of carrying out the transport work safely. Twisting and sideways movements are more common behind the cab but diminish the further back along the truck one goes. In addition, lengthways and sideways forces must be absorbed by the attachments. Along the front part of the sub frame / helper-frame, the attachments should be pivoted as much as possible so as to allow maximum chassis movement in relation to the road/ground. For the most rigid bodywork, flexible two-way attachments are used along the whole length of the frame. The bodywork must have the freedom to move in relation to the chassis frame. The more rigid the bodywork, the greater the movement in the attachment is required. With the exception of the most rigid bodywork, attachment plates are used along the rear section of the sub frame/helper-frame.

Figure - 10

Clamps and Recommended Attachments

Bodywork Torsionally flexible	Attachment			
	Front section		Rear section	
	RC-SMOOT	RC-ROUGH/VROUG	RC-SMOOT	RC-ROUGH/VROUG
Concrete mixer Tip Rigid platform Load changer Flat bed with tilt	Pivoted	Flexible one-way	Standard plate	First position pivoted Medium thickness or heavy plate
Timber bank Timber and sugar cane platform Timber bed Lift dumper Concrete pumps Skip lifter	Pivoted	Flexible one-way	Standard plate	First position pivoted Medium thickness or heavy plate
Concrete pumps Box (very stiff) Refuse collection body (side and front mounted)	Flexible one-way	Elastic one-way	Standard plate	First position pivoted Medium thickness or heavy plate
Bulk carrier Refuse truck (i.e. rear end loader)	Elastic two-way	Elastic two-way	Flexible one-way and/or Medium thickness or heavy plate	Elastic two-way
Bodywork Torsionally stiff				
Slurry tanker Tank	Elastic two-way	Elastic two-way	Elastic two-way	Elastic two-way

RC-SMOOT = Road conditions, smooth conditions

RC-ROUGH/VROUG = Road conditions, rough/very rough conditions

Note: For some of the positions shown in the table above, a choice of attachments can be made. This choice is dependent on the type of bodywork and bogie used.

Note: The above table specifies the minimum requirements. More flexible anchorages or stronger plates can also be selected.

Figure - 11
Body Work and Recommended Attachments



Figure - 12
Typical Types of Closed Bodies.

SECTION - 4.0**REQUIREMENTS OF LIGHTING, ILLUMINATION,
ELECTRICAL EQUIPMENT AND WIRING****LIST OF CONTENTS**

4.1	Lighting, Signalling and Indicating Systems
4.1.1	External
4.1.2	Internal
4.1.3	Position of illumination devices
4.1.4	Type of Bulbs for lamp Assemblies
4.2	Driver Cab lighting
4.3	Electrical Equipment and Wiring
4.3.1	Electrical cables
4.3.2	Fuse
4.3.3	Terminals, Connectors and Elements
4.4	Safety requirements
4.5	Batteries
4.6	Type Approval

4.1 Lighting, Signalling and Indicating Systems

4.1.1 External

4.1.1.1 External lighting, signalling and indicating systems of the truck shall comply with the Rules laid down of the Central Motor Vehicle Rules, 1989, and as amended from time to time.

4.1.1.2 Lighting and signalling equipment fitted shall be as type approved. This shall be checked at the time of registration and subsequently during annual fitness certification by the registering authority.

4.1.1.3 Inspection lamp shall be provided in the engine compartment. This is optional for vehicles with tiltable cab.

4.1.2 Internal

4.1.2.1 Lighting, signalling and indicating systems shall provide adequate illumination inside the truck for the safe operation by the driver and the co-driver, during darkness and other conditions of reduced visibility.

4.1.3 Position of illumination devices

4.1.3.1 Cab lamp or courtesy lamp on left and right hand sides shall be placed, preferably above the head level of the occupant. Alternately one lamp in the center of the cab roof may be provided.

4.1.3.2 Exit lamps for the driver and co-driver side may be placed for illumination below the seat level

4.1.3.3 The following optional lamps are to be placed inside the compartment / unit/control.

4.1.3.3.1 Locker lamp

4.1.3.3.2 Electrical distribution centre lamp - Instrument lighting

4.1.3.3.3 Control unit lamps

4.1.4 Type of bulbs for lamp assemblies

4.1.4.1 The following lamp assemblies can be illuminated either by incandescent bulbs or L.E.D, fluorescent lamps or other types

- Tell-Tale lights
- Instrument lights
- Control unit lamp

4.1.4.2 The following lamp assemblies may be illuminated by incandescent bulbs,

- Electrical distribution centre lamp
- Locker lamp

- 4.1.4.3 The following lamp assemblies may be illuminated by incandescent bulbs or fluorescent bulbs,
- Entrance lamps
 - Cab lamp or courtesy lamp
 - Passenger area lamp
- 4.1.4.4 Photometric Requirements
- 4.1.4.4.1 Lighting requirements of the lighting, signalling and indicating systems for the following sub groups,
- Dash Board Tell-Tale Lighting/Control Lighting
 - Driver Cab Lighting
 - Other Area Lighting
- 4.1.4.4.2 Dash Board Tell -Tale Lighting/Control Lighting
- 4.1.4.4.2.1 Lamps falling in this category -
- Instrument lighting
 - Tell-Tale lighting
 - Control unit lamps
- 4.1.4.4.2.2 The illumination by lighting devices lighting up dash board instruments, tell tales and controls shall be discreet and shall not disturb the driver when driving in the dark.
- 4.1.4.4.2.3 The regulation of the intensity of illumination of instrument lighting shall be optional. If available, the strength of the instrument lighting shall be capable of regulation through a rheostat or any other suitable means.
- 4.2 Driver cab lighting**
- 4.2.1 The following lamps fall in this category,
- Cab lamp or courtesy lamp
 - Locker lamp
 - Electrical distribution lamp
- 4.2.2 The illumination by lighting devices lighting up the cab interior should be sufficient enough to clearly distinguishing component part of the cab. Driver should be in a position to read signage written on the walls, door of the cab. He should also be in position to read any instructions printed on paper
- 4.3 Electrical Equipment and Wiring**
- 4.3.1 **Electrical cables**
- 4.3.1.1 All cables used shall be compliant with IS/SAE/JIS/DIN/JASO/ISO or any equivalent standards. Copper conductors with fire retardant PVC insulation and able to withstand working temperatures.

4.3.1.2 All the cables shall be ducted and secured at suitable places in such a manner that during normal use of vehicle the cables are not subjected to any tension, stretching, nicking, cutting, abrasion, or chaffing. Some examples are as given in Figure 1 and Figure 2.

4.3.2 **Fuse**

4.3.2.1 Every electrical circuit shall be provided with fuse designed for the circuit. In case of multiple circuits a common fuse may be permitted.

4.3.3 **Terminals, Connectors and Elements :**

4.3.3.1 **End terminations:** All the ends shall be suitably crimped with lugs / soldered or fixed so as to withstand vehicle vibrations. The interconnection shall be through couplers / junction boxes/ terminal blocks. Some of the correct and incorrect methods of clamping are as indicated in Figures - 1, 2 and 3.

4.3.3.2 Weatherproof connectors shall be used for external areas to avoid water/ moisture ingress during use.

4.3.3.3 All wiring must be anchored to the chassis at intervals of not more than 600 mm along its length. (Refer Figures 4, 5 and 7)

4.3.3.4 All wiring must be insulated at joints and also wiring must be located in such a position that it can neither become overheated nor contact moving parts. Some example of wiring on the cab and body of the vehicle areas indicated in Figures 4 to 7.

4.3.3.5 In case of trailers and towing vehicles the 7-pin connector, 12- pin connector or 15-pin connector as indicated in Figures - 8, 9, 10 & 11, shall be used. Guidelines for electrical connections between towing vehicles and trailers may be drawn from IS: 13460, IS: 13461, IS: 13491 and IS: 13499.

4.4 Safety requirements

4.4.1 Use of relays and other electrical elements shall be adopted where the current rating of the switches is not adequate.

4.4.2 The additional circuits shall not draw current more than specified by the manufacturer.

4.4.3 Where the voltage exceeds 100 Volts RMS (Root Mean Square) in one or more electrical circuit, a manually operated isolation switch, which is capable of disconnecting the circuit(s) from the main electrical supply, shall be provided and shall be located inside the vehicle in a location easily accessible to the driver. Alternatively battery cut off switch may be provided.

4.4.4 The electrical circuit provided by the vehicle manufacturer which is type approved shall not be modified. However, additional circuits may be made with the concurrence of OEM or as per the recommended practice of OEM. Provisions for tapping / socket / connector be provided for enabling use of external inspection lamp.

This will be useful for repairs if the vehicle is stranded on road.

4.4.5 Electrical cables shall be located such that no part can make contact with any fuel line or exhaust system subjected to excess heat. Suitable special insulation shall be provided where such electrical circuits are necessary.

4.5 Batteries

4.5.1. All batteries shall be well secured and easily accessible.

4.5.2 The battery compartment shall be separated from the driver’s compartment and be preferably located outside the cab. It shall be well ventilated.

4.5.3 Battery terminals shall be protected against short circuit risk.

4.5.4 **Isolation switch:** A manually or electrically operated isolation switch, which is capable of disconnecting the battery terminal from the electrical circuit, shall be provided.

4.6 Type Approval

4.6.1 The electrical layout, the number of lamps, their position, type and wattage used in the vehicle shall be type approved.

4.6.2 All the above information shall be incorporated in the technical specification submitted for the type approval.

4.6.3 The Table below shows the different standards related to the cables used in truck body wiring. These are recommendatory standards provided as guidelines for the vehicle / body manufacturer to select or any other International standard may also be complied.

Table: Different Standards for Cables

Description	Standard Ref.
Cables for motor vehicles	IS 2465: 1984
Cable Termination for Automobile Wiring Blade Type Connectors	IS 8395: 1977 Part I
Cable Termination for Automobile Wiring Bullet & Tube Type Connectors	IS 8395: 1977 Part II
Low Voltage Fuses	IS 13703 : 1993 Part I
Colour Code of Electrical Wiring	IS 13313 : 1991
Cartridge Fuse links for Automobiles	IS 2577 : 1974
Porcelain (Molded) Fuse links for Automobiles	IS 7528:1974
Fuses for Automobiles	IS 4063 : 1982
Selection of Conductor Size	JASO D0609-75 AV
Piano key type switches for use in automobiles	IS 9433: 1980
Automobile Lamps	IS 1606:1979
Electrical Circuits	IS 14381 : 1996

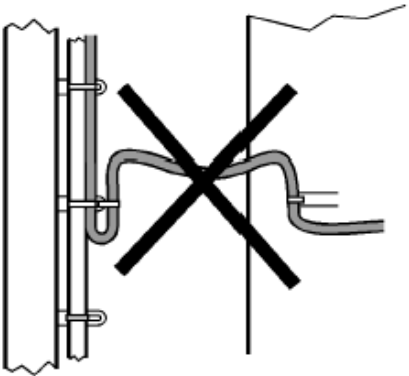
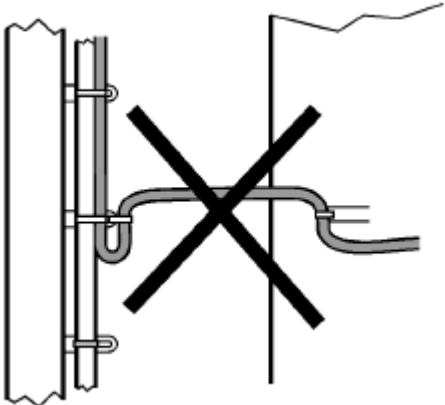
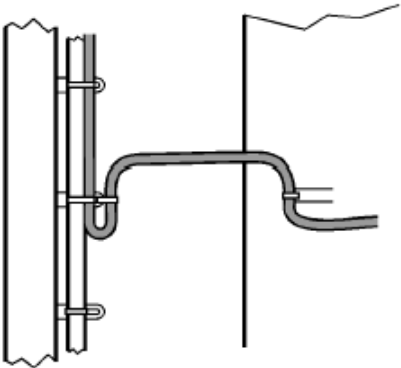
	<p>Cable too long</p>
	<p>Cable too short</p>
	<p>Cable correctly clamped</p>
<p>Figure -1 Clamping and Length of Cables</p>	

Correct clamping

- Cables which are too long should be clamped together to form a single coil with free ends. The cables are thus still there and can be re-used as necessary.

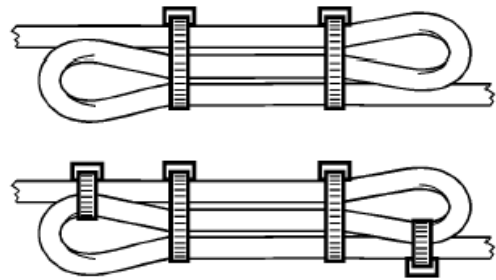

Faulty clamping

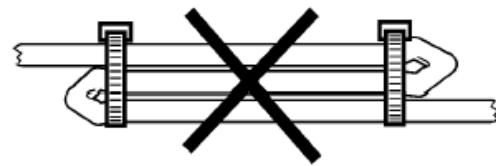

Clamping of cables to solenoid valves and cable joints

- When cables are clamped to components, a loop should be formed. The loop allows components to be changed and stops water from being led into the component via the cable. Make sure that the strip clamp ends up on the protective sheath of the cable. The exception is cables with a corrugated sheath, the so-called "Schlemmer hoses".

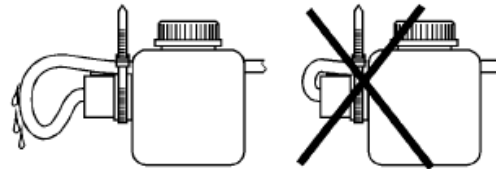

TS007079

Clamping of cables to solenoid valve

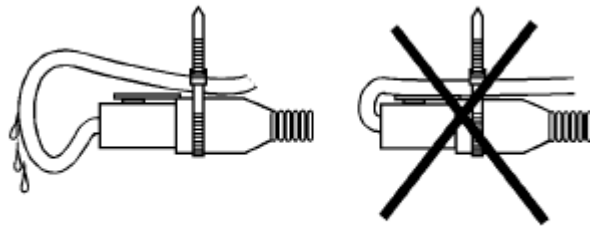

TS007080

Clamping of cable joints

Figure 2
Clamping and joints

Clamping of cables with a corrugated sheath

- Clamping of cables with a corrugated sheath, the so-called "Schlemmer hoses" shall be done as in the illustrations below

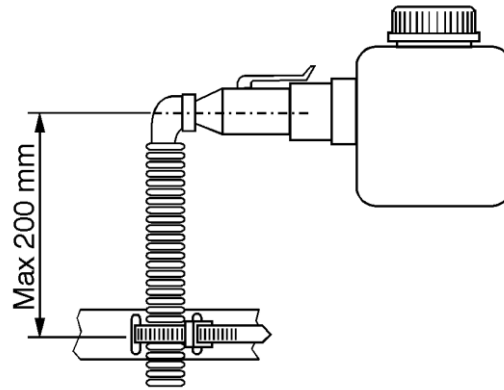
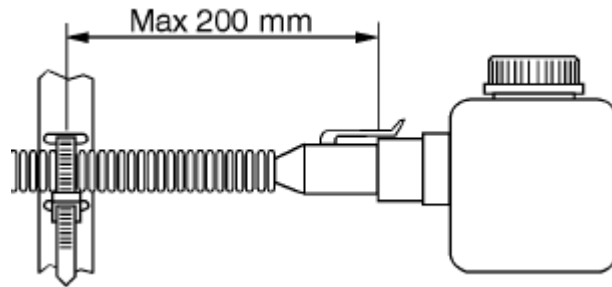

Figure 3

Clamping with Corrugated Sheath

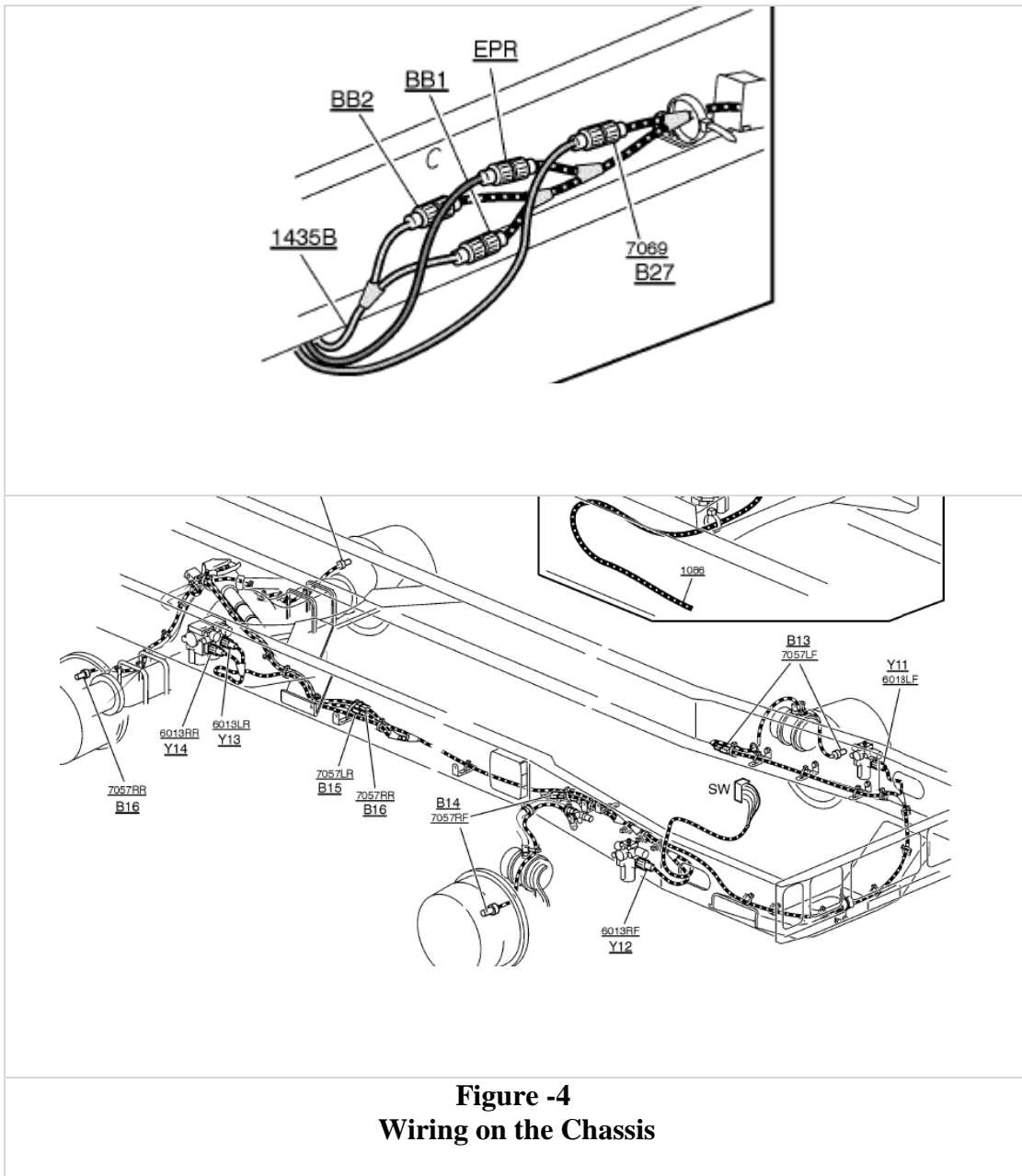

Figure -4
Wiring on the Chassis

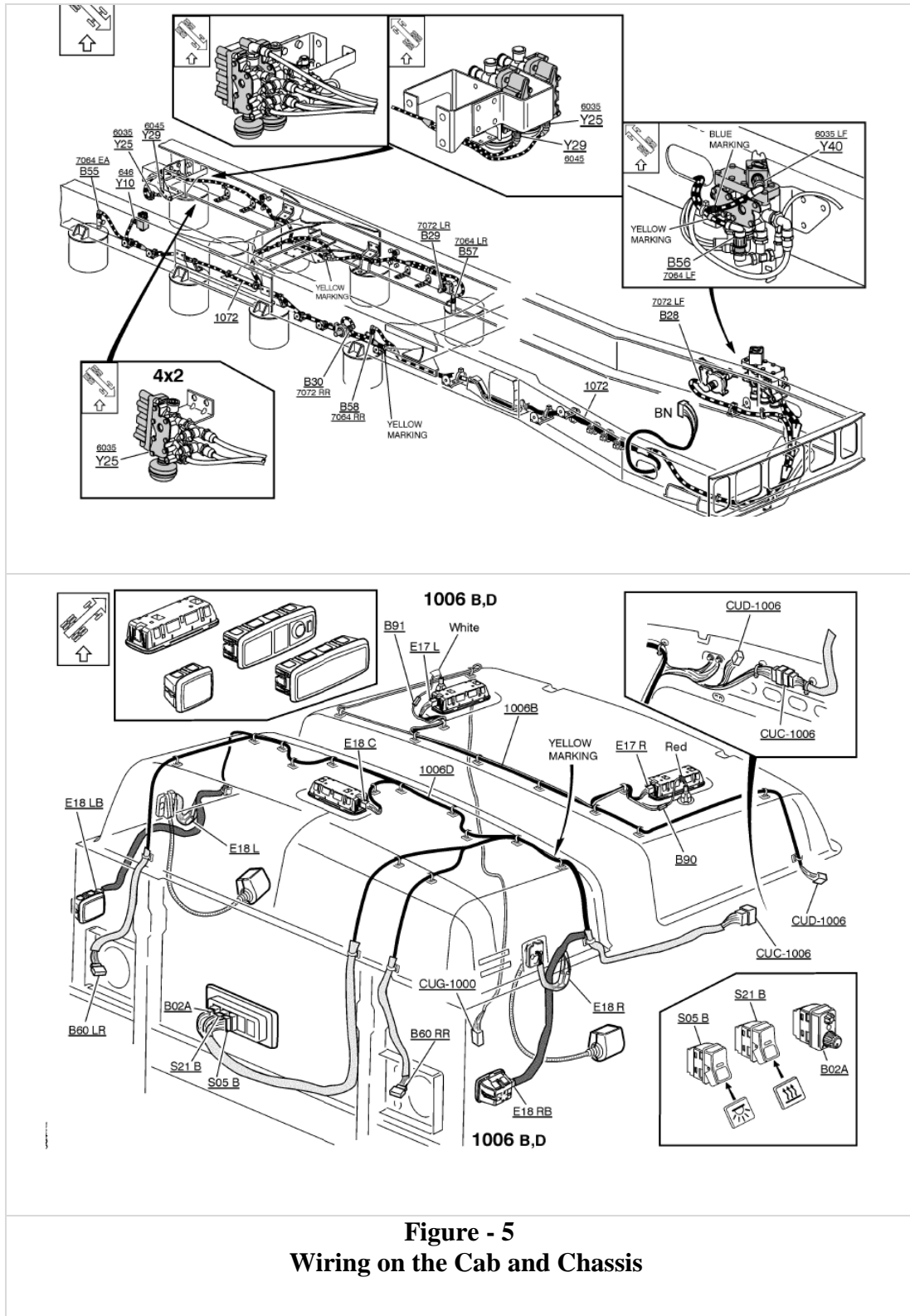

Figure - 5
Wiring on the Cab and Chassis

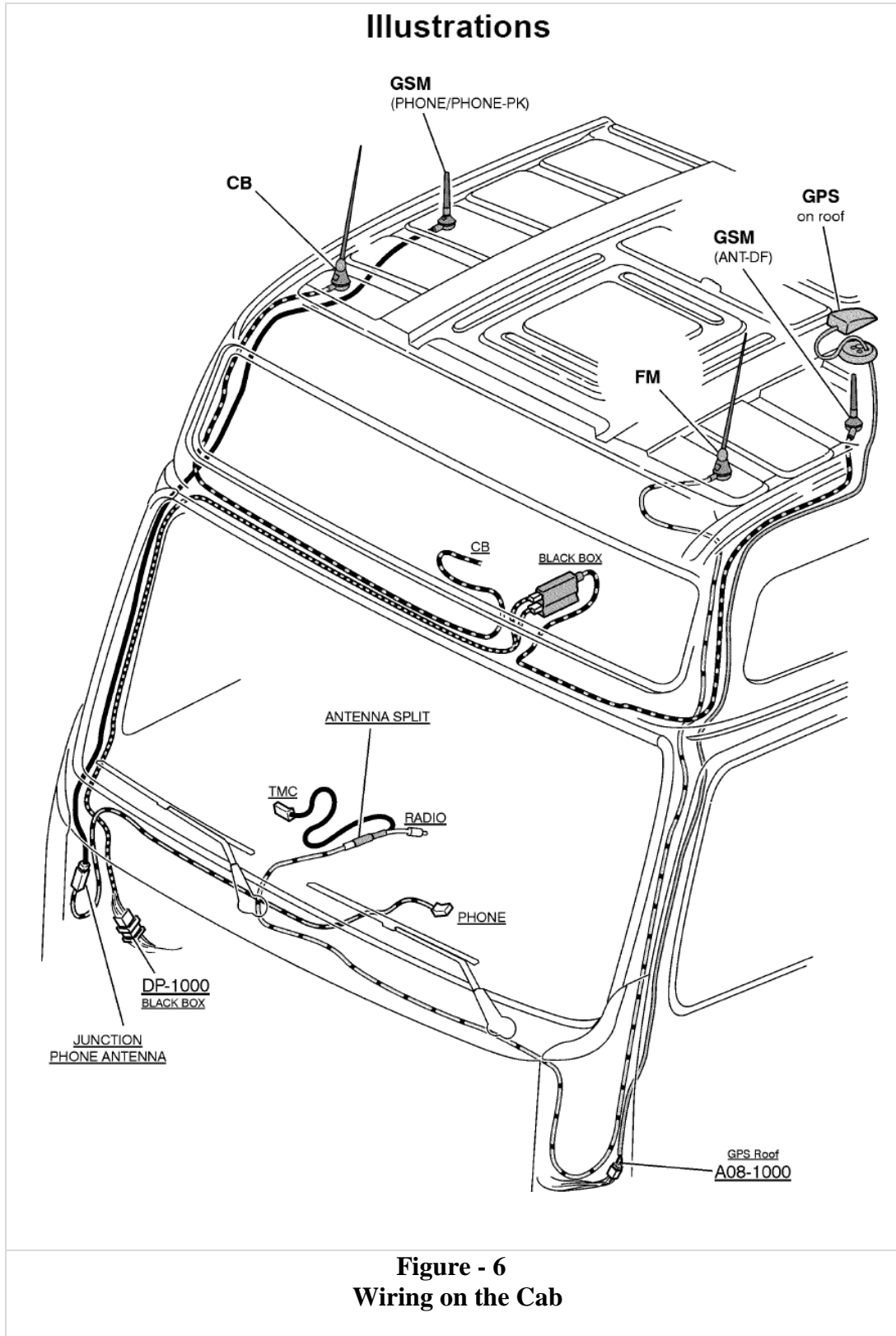

Figure - 6
Wiring on the Cab

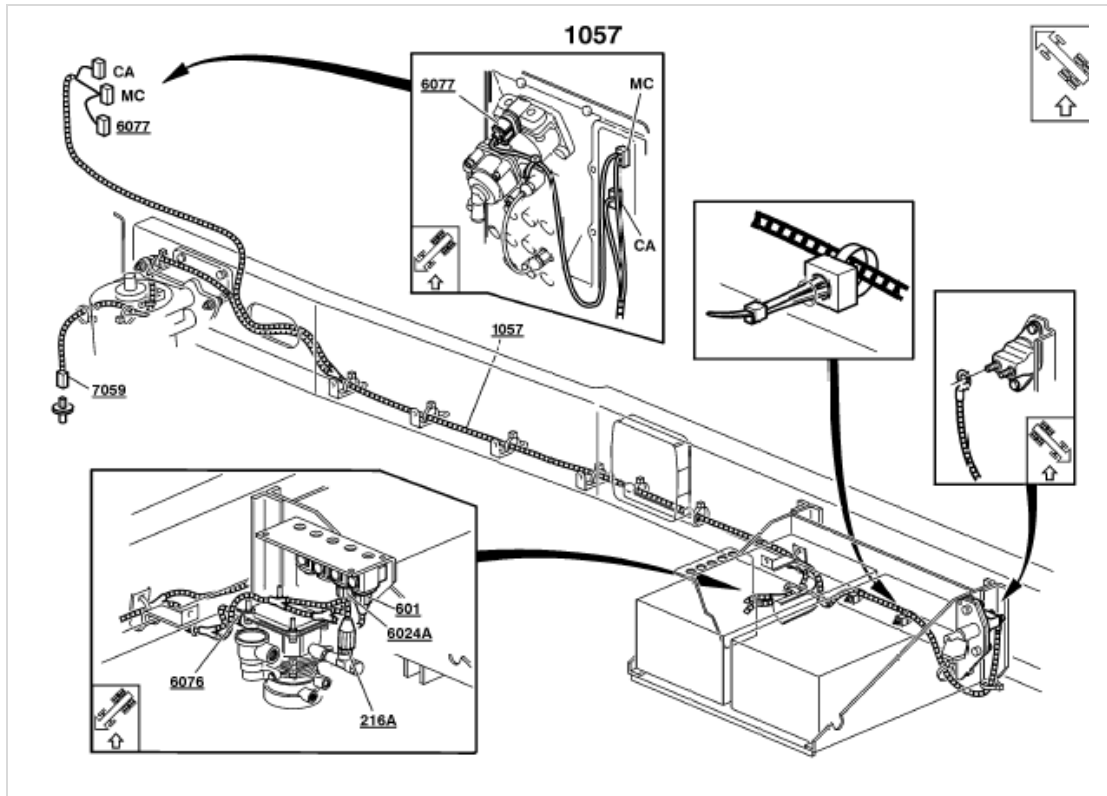

Figure - 7
Wiring on the Chassis

Trailer connectors

There are two different 7-pin trailer connectors, one for trailer connection and the other for auxiliary equipment on the trailer. The appearance of pin 1 differs, please refer to the adjacent illustrations.

Connector 24N (component number 77 in the wiring diagram in the service literature, group 37) ISO1185, is used for trailer connection. The pins are intended for:

- 1 Earth, kl.31.
- 2 Tail lamp, left, 58L, Max 8 A, fuse 34.
- 3 Indicator, left, L, Max 3 x 21 W.
- 4 Brake lamp, 54, Max 6 A, fuse 6.
- 5 Indicator, right, R, Max 3 x 21 W.
- 6 Tail lamp, right, 58R, Max 8 A, fuse 36.
- 7 Unused pin. Cable, marked 54G, connected to the coachbuilder's distribution box, as in the adjacent illustration.

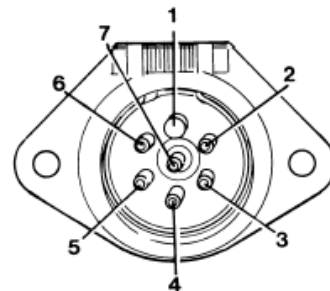

T3006274

Connector 24S (component number 78 in the wiring diagram in the service literature, group 37) ISO3731, is used for auxiliary equipment on the trailer. The pins are intended for:

- 1 Earth, kl.31.
- 2 Unused pin.
- 3 Reversing lamp, Max 8 A together with the tractor unit reversing lamp, fuse 44. For connection of extra (reinforced reversing lamp), please refer to Section 4.90 "Reverse gear".
- 4 B+ from battery, Max 8 A together with other equipment connected to the coachbuilder fuse box, fuse 1 in coachbuilder fuse box 56X.
- 5 Unused pin, cable connected to RC12 in right cab transition E:

- 6 Kl.15 via ignition, Max 8 A together with other equipment connected to the coachbuilder fuse box, fuse 3 in coachbuilder fuse box 56X.

- 7 Rear fog lamp

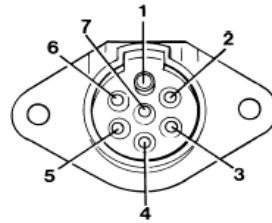

Figure- 8
7- Pin trailer connection and details

Junction box for trailers

Junction boxes for trailers are only installed on RIGID trucks and are installed in the right chassis member, 700 mm in front of the end of the chassis.

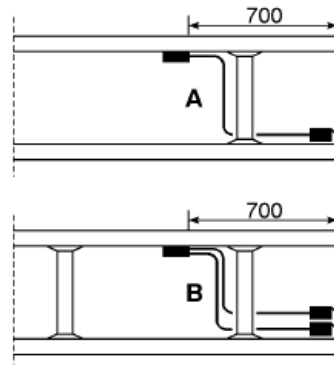
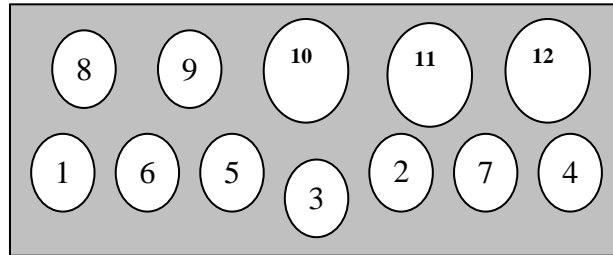

Figure - 9
Junction box for trailers

12 – pin trailer connection



Pin number	Circuit conductor
1	Left-hand turn
2	Reversing signal
3	Earth return
4	Right-hand turn
5	service brakes
6	Stop lamps
7	Rear lamps, clearance and side marker lamps
8	Battery charger/electric winch
9	Auxiliaries, etc/battery feed
10	Earth return
11	Rear fog lamp
12	Auxiliary

Figure-10
12-Pin tractor connection and details

15- pin trailer connection

There are also trucks which have a 15-pin ISO 12098 trailer connection. The standard stipulates the following functionality:

Pin No	Function
1	Indicator, left
2	Indicator, Right
3	Rear fog lamp
4	Earth Connection
5	Parking lamp circuit, left
6	Parking lamp circuit, right
7	Brake lamps
8	Reversing lamps
9	Power Supply (+24 V)
10	sensor, wear, brake linings
11	Pressure sensor, spring brakes
12	Axle lift
13	Return cable, pin no 14 and 15
14	Reserved for data communication
15	Reserved for data communication

Figure -11
Details of 15- Pin trailer connection

SECTION - 5.0**ADDITIONAL REQUIREMENTS FOR VEHICLES CARRYING
DANGEROUS AND HAZARDOUS GOODS WITH REGARD TO
THEIR SPECIFIC CONSTRUCTIONAL FEATURES****LIST OF CONTENTS**

5.1	Scope
5.2	Definitions
5.3	Technical Provisions for Base Vehicles
5.4	Technical Provisions for Bodies
5.5	Manner of Display of Class Labels and Identification Marks
5.6	Essential Equipment and Documents to be carried in the Vehicle
5.7	Driver Training Requirements
5.8	Periodic Inspection of Vehicles
5.9	Type Approval Process

5.1 SCOPE

This chapter applies to the construction of motor vehicles of category N and their trailers of categories T3 and T4 which are subject to carriage of dangerous and hazardous goods by road.

5.2 DEFINITIONS

- 5.2.1 **"Vehicle type"** means vehicles, which do not differ essentially with regard to the constructional features specified in this chapter.
- 5.2.2 **"Vehicle"** means any vehicle, whether complete (e.g. one stage built vans, lorries, tractors, trailers), incomplete (e.g. chassis, chassis-cab, trailer-chassis) or, completed (e.g. chassis-cab fitted with a bodywork), intended for the carriage of dangerous and hazardous goods by road.
- 5.2.3 **"EX / II vehicle" or "EX/III vehicle"** means a vehicle intended for the carriage of explosives substances and articles (Class 1).
- 5.2.4 **"FL vehicle"** means a vehicle intended for the carriage of liquids having a flash-point of not more than 60 °C (with the exception of diesel fuel complying with standard EN 590: 2004, gas oil, and heating oil (light) - UN No.1202 - with a flash-point as specified in standard EN 590: 2004) or flammable gases, in tank-containers, portable tanks or MEGCs of more than 3 m³ capacity, fixed tanks or demountable tanks of more than 1 m³ capacity or a battery vehicle of more than 1 m³ capacity intended for the carriage of flammable gases.
- 5.2.5 **"OX vehicle"** means a vehicle intended for the carriage of hydrogen peroxide, stabilized or hydrogen peroxide, aqueous solution stabilized with more than 60 per cent hydrogen peroxide (Class 5.1, UN No. 2015) in tank-containers or portable tanks of more than 3 m³ capacity, fixed tanks or demountable tanks of more than 1 m³ capacity.
- 5.2.6 **"AT vehicle"** means a vehicle, other than EX/III, FL or OX, intended for the carriage of dangerous and hazardous goods in tank containers, portable tanks or MEGCs of more than 3 m³ capacity, fixed tanks or demountable tanks of more than 1 m³ capacity or a battery vehicle of more than 1 m³ capacity other than an FL vehicle.

Note 1 :

- Petroleum Class A - petroleum having a flash-point below 23 degrees centigrade
- Petroleum Class B - petroleum having a flash point of 23 degrees centigrade and above but below 65 degrees centigrade
- Petroleum Class C - petroleum-having flash point of 65 degrees and above

Note 2 :

Explosive means gunpowder, nitroglycerine, nitroglycol, gun-cotton, di-nitro-toluene, tri-nitro-toluene, picric acid, di-nitor-phenol, tri-nitor-resorcinol (styphnic act), cyclo-trimethylene-trinitramine, penta-erythritol-tetranitrate, tetryl, nitroguanidine, lead azide, lead styphynate, fulminate of mercury or any other metal, diazo-di-nitor-phenol, coloured fires or any other substance whether a single chemical compound or a mixture of substances, whether solid or liquid or gaseous used or manufactured with a view to produce a practical effect by explosion or pyrotechnic effect; and includes fog-signals, fireworks, fuses, rockets, percussion caps, detonators, cartridges, ammunition of all descriptions and every adaptation or preparation of an explosive as defined in this note.

5.3 Technical provisions for base vehicles : Vehicles shall, depending on the vehicle designation, comply with the provisions below.

5.3.1 Electrical equipment :

5.3.1.1 General provisions : The electrical installation as a whole shall meet the following provisions, in accordance with the table of Paragraph 5.3.1.2.1, below.

5.3.1.2 Wiring :

5.3.1.2.1 The size of conductors shall be large enough to avoid overheating. Conductors shall be adequately insulated. All circuits shall be protected by fuses or automatic circuit breakers. However, the following cases may be exempted

- from the battery to cold start and stopping systems of the engine
- from the battery to the alternator
- from the battery to the starter motor
- from battery to tachograph, if fitted

from the battery to the power control housing of the endurance braking system, if this system is electrical or electromagnetic from the battery to the electrical lifting mechanism for lifting the bogie axle

The above unprotected circuits shall be as short as possible.

Technical Specification	Vehicle Designation				
	EX/II	EX/III	AT	FL	OX
Electrical Equipment					
Wiring		X	X	X	X
Battery master switch		X		X	
Batteries	X	X		X	
Tachographs, if fitted		X		X	
Permanently energised installations		X		X	
Electrical installation behind cab		X		X	

5. 3.1.2.2 Cables shall be securely fastened and positioned in such a way that the conductors are adequately protected against mechanical and thermal stresses.
5. 3.1.3 **Battery Master Switch :**
5. 3.1.3.1 A switch for breaking the electrical circuits shall be placed as close to the battery as possible.
5. 3.1.3.2 A control device to facilitate the disconnecting and reconnecting functions of the switch shall be installed in the driver's cab. It shall be readily accessible to the driver and be distinctively marked. It shall be protected against inadvertent operation by either adding a protective cover, or by using a dual movement control device or by other suitable means. Additional control devices may be installed provided they are distinctively marked and protected against inadvertent operation.
5. 3.1.3.3 It shall be possible to open the switch while the engine is running, without causing any dangerous excess voltage. Operation of the switch shall not constitute a fire hazard in an explosive atmosphere; this can be ensured by using a switch having a casing with protection degree IP65 in accordance with IEC Standard 60529.
5. 3.1.3.4 The cable connections on the battery master switch shall have a protection degree IP54. However, this does not apply if these connections are contained in a housing which may be the battery box. In this case it is sufficient to insulate the connections against short circuits, for example with a rubber cap.
5. 3.1.4 **Batteries :** The battery terminals shall be electrically insulated or covered by the insulating battery box cover. If the batteries are not located under the engine bonnet, they shall be fitted in a vented box.
5. 3.1.5 **Tachographs :** Tachographs, if fitted, on vehicles shall comply with the requirements stated in AIS-059 as amended from time to time.
5. 3.1.6 **Permanently Energised Installations :**
5. 3.1.6.1 Those parts of the electrical installation, other than the tachograph, which remain energised when the battery master-switch is open, shall be suitable for use in a hazardous area and shall meet the appropriate requirements of European Standard IEC 60079 and one of IEC 60079-1, 60079-2, 60079-7, 60079-11 and 60079-18. The requirements for the relevant gas group according to the product being carried shall be met.
5. 3.1.6.2 Bypass connections to the battery master switch for electrical equipment which must remain energised when the battery master switch is open shall be protected against overheating by suitable means, such as a fuse, a circuit breaker or safety barrier (current limiter).

5. 3.1.7 **Provisions concerning that part of the electrical installation situated to the rear of the driver's cab :** The whole installation shall be so designed, constructed and protected such that it cannot provoke any ignition or short-circuit under normal conditions of vehicle use and that these risks can be minimised in the event of an impact or deformation. In particular:
5. 3.1.7.1 **Wiring :** The wiring located behind the drivers cab shall be protected against impact, abrasion and chafing during normal vehicle operation. Examples of appropriate protection are given in the Figures 1, 2, 3 and 4. However, the sensor cables of anti-lock braking devices do not need additional protection.
5. 3.1.7.2 **Lighting :** Lamp bulbs with a screw cap shall not be used.
5. 3.1.7.3 **Electrical connections :** Electrical connections between motor vehicles and trailers shall have a protection degree IP54 in accordance with IEC Standard 60529 and be designed to prevent accidental disconnection. Examples of appropriate connections are given in ISO 12 098:2004 and ISO 7638:2003 and EN 15207:2006 or any other Indian / International standards as appropriate.
5. 3.1.7.4 **Electrical lifting mechanism :** The electrical equipment of the mechanism for lifting a bogie axle shall be installed outside the chassis frame in a sealed housing.
5. 3.1.8 **Prevention of fire risks :** Compliance to Petroleum Rules and Explosive Rules shall be ensured by PESO.
5. 3.1.8.1 **Vehicle cab**
5. 3.1.8.1.1 Only material not readily flammable shall be used in the construction of the driver's cab. This provision will be deemed to be met if, in accordance with the procedure specified in ISO Standard 3795:1989, samples of the following cab components have a burn rate not exceeding 100 mm / min seat cushions, seat backs, safety belts, head lining, opening roofs, arm rests, all trim panels including door, front, rear and side panels, compartment shelves, head restraints, floor coverings, sun visors, curtains, shades, wheel housing covers, engine compartment covers, mattress covers and any other interior materials, including padding and crash-deployed elements, that are designed to absorb energy on contact by occupants in the event of a crash.
5. 3.1.8.1.2 Unless the driver's cab is made of not readily flammable materials, a shield made of metal or other suitable material of the same width as the tank shall be fitted at the back of the cab. Any windows in the back of the cab or in the shield shall be hermetically closed and made of fire resistant safety glass with fire resistant frames. Furthermore, there shall be a clear space of not less than 15 cm between the tank and the cab or the shield.

5. 3.1.8.2 **Fuel tanks :** The fuel tanks for supplying the engine of the vehicle shall meet the following requirements.
5. 3.1.8.2.1 In the event of any leakage, the fuel shall drain to the ground without coming into contact with hot parts of the vehicle or the load.
5. 3.1.8.2.2 Fuel tanks containing petrol shall be equipped with an effective flame trap at the filler opening or with a closure with which the opening can be kept hermetically sealed.
5. 3.1.8.3 **Engine :** The engine propelling the vehicle shall be so equipped and situated to avoid any danger to the load through heating or ignition. In the case of vehicles designated EX/II and EX/III the engine shall be placed forward of the front wall of the load compartment: it may nevertheless be placed under the load compartment, provided this is done in such a way that any excess heat does not constitute a hazard to the load by raising the temperature on the inner surface of the load compartment above 80⁰C. (1)
5. 3.1.8.4 **Exhaust system :** The exhaust system as well as the exhaust pipes shall be so directed or protected to avoid any danger to the load through heating or ignition. Parts of the exhaust system situated directly below the fuel tank (diesel) shall have a clearance of at least 100 mm or be protected by a thermal shield. The exhaust system of vehicles designated EX/II and EX/III shall be so constructed and situated that any excess heat shall not constitute a hazard to the load by raising the temperature on the inner surface of the load compartment above 80⁰C. Compliance with these requirements shall be verified on the completed vehicle.

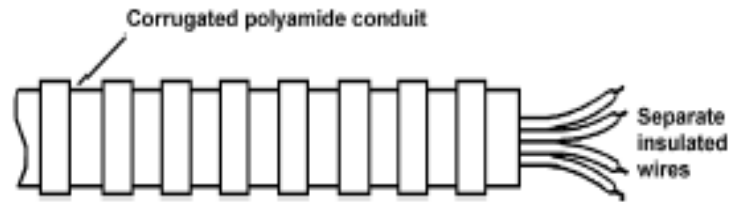

Figure No. 1

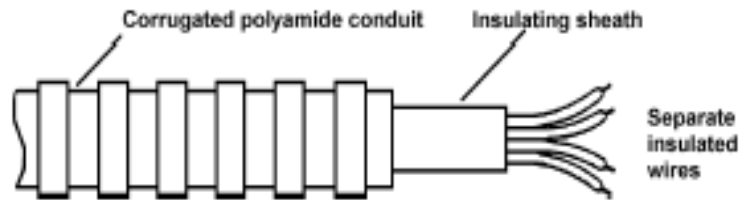

Figure No. 2

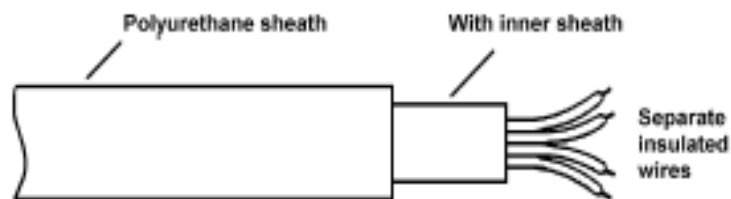

Figure No. 3

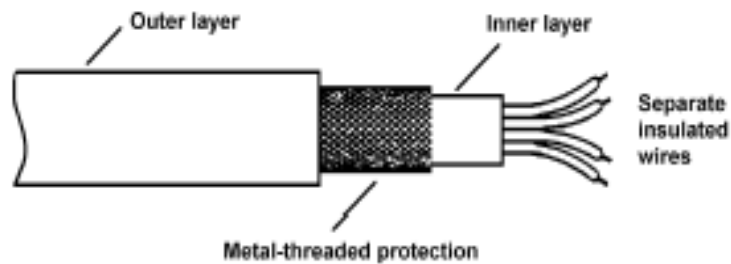

Figure No. 4

5.3.1.8.5 **Vehicle endurance braking system :**

5.3.1.8.5.1 Endurance braking system means a system intended to stabilize vehicle speed on a long descent, without the use of the service, secondary or parking braking systems.

5.3.1.8.5.2 Vehicles equipped with endurance braking systems emitting high temperatures placed behind the rear wall of the driver's cab shall be equipped with a thermal shield securely fixed and located between this system and the tank or load so as to avoid any heating, even local, of the tank shell or the load. In addition, the thermal shield shall protect the braking system against any outflow or leakage, even accidental, of the load. For instance, a protection including a twin-shell shield shall be considered satisfactory.

- 5.3.1.8.5.3 Fitment of Endurance braking system shall be as per CMVR & it shall fulfill the requirements stated in IS 11852 as amended from time to time.
- 5.3.1.8.5.4 If a trailer is equipped with an endurance braking system it shall fulfill the requirements stated in IS 11852, and the provisions of 5.3.1.8.5.3 (a) to (d) above.
- 5.3.1.8.6 **Emergency braking devices for trailers :**
- 5.3.1.8.6.1 Trailers shall be equipped with an effective system for braking or restraining them if they become detached from the motor vehicle towing them.
- 5.3.1.8.6.2 Trailers shall be fitted with an effective braking device, which acts on all the wheels, is actuated by the drawing vehicle's service brake control and automatically stops the trailer in the event of breakage of the coupling.
- 5.3.1.8.7 **Combustion heaters :**
- 5.3.1.8.7.1 The combustion heaters and their exhaust gas routing shall be designed, located, protected or covered so as to prevent any risk of unacceptable heating or ignition of the load. This requirement shall be considered as fulfilled if the fuel tank and the exhaust system of the appliance conform to provisions similar to those prescribed for fuel tanks and exhaust systems of vehicles in Paragraphs 5.3.1.8.2 and 5.3.1.8.4 respectively.
- 5.3.1.8.7.2 The combustion heaters shall be put out of operation by at least the following methods :
- (a) Intentional manual switching off from the driver's cab.
 - (b) Unintentional stopping of the vehicle engine; in this case the heating device may be restarted manually by the driver.
 - (c) Start up of a feed pump on the motor vehicle for the dangerous and hazardous goods carried.
- 5.3.1.8.7.3 After running is permitted after the combustion heaters have been put out of operation. For the methods of Paragraphs 5.3.1.8.7.2 (b) and (c) above the supply of combustion air shall be interrupted by suitable measures after an after-running cycle of not more than 40 seconds. Only heaters shall be used for which proof has been furnished that the heat exchanger is resistant to the reduced after running cycle of 40 seconds for the time of their normal use.
- 5.3.1.8.7.4 The combustion heater shall be switched on manually. Programming devices shall be prohibited.

- 5.3.1.9 **Braking equipment** : In addition to the following technical provisions, to be applied in accordance with the table of 5.3.1.2, motor vehicles and trailers intended for use as transport units for dangerous and hazardous goods shall fulfill all relevant technical requirements of IS :11852 including that of Part 9 as amended from time to time.
- 5.3.1.10 **Speed limiting devices** : Motor vehicles (rigid vehicles and tractors for semi- trailers) with a maximum mass exceeding 12 tonnes, shall be equipped with a speed limiting device complying to AIS-018. The speed limit value, shall be as that enforced by the State Road Transport Authority.
- 5.3.2 **Additional requirements concerning complete or completed EX/II or EX/III vehicles** :
- 5.3.2.1 **Materials to be used in the construction of vehicle bodies** : No materials likely to form dangerous compounds with the explosive substances carried shall be used in the construction of the body.
- 5.3.2.2 **Combustion heaters** : Combustion heaters shall not be installed in load compartments of EX/II and EX/III vehicles. Combustion heaters shall meet the additional requirements.
- (a) The switch may be installed outside the driver's cab.
- (b) The device may be switched off from outside the load compartment and
- (c) It is not necessary to prove that the heat exchanger is resistant to the reduced after running cycle.
- 5.3.2.3 **EX/II vehicles** : The vehicles shall be designed, constructed and equipped so that the explosives are protected from external hazards and the weather. Shall be approved by **PESO**.
- 5.3.2.4 **EX/III vehicles** : These vehicles shall be closed. The loading surface, including the front wall, shall be continuous.
- 5.3.2.5 **Load compartment and engine** : The engine shall be placed forward of the front wall of the load compartment; it may nevertheless be placed under the load compartment, provided this is done in such a way that any excess heat does not constitute a hazard to the load by raising the temperature on the inner surface of the load compartment above 80°C.
- 5.3.2.6 **Load compartment and exhaust system** : The exhaust system of EX/II and EX/III vehicles or others parts of these complete or completed vehicles shall be so constructed and situated that any excess heat shall not constitute a hazard to the load by raising the temperature on the inner surface of the load compartment above 80 °C.

5.3.2.7 **Electrical equipment :**

5.3.2.7.1 The electrical installation on EX/III vehicles shall meet the requirements of 5.3.1.2.

5.3.2.7.2 The electrical installation in the load compartment shall be dust-protected.

5.4 Technical Provisions for Bodies

5.4.1 Additional requirements concerning the construction of the bodies of complete or completed vehicles intended for the carriage of dangerous and hazardous goods in packages (other than EX/II and EX/III vehicles).

5.4.1.1 Combustion heaters shall meet the following requirements :

- (a) The switch may be installed outside the driver's cab.
- (b) The device may be switched off from outside the load compartment and
- (c) It is not necessary to prove that the heat exchanger is resistant to the reduced after running cycle.

5.4.1.2 If the vehicle is intended for the carriage of dangerous and hazardous goods for which a label conforming to the CMV Rules 137, shall be provided. No fuel tank, power source, combustion air or heating air intakes as well as exhaust tube outlets required for the operation of the combustion heater shall be installed in the load compartment. It shall be ensured that the heating air outlet cannot be blocked by cargo. The temperature to which packages are heated shall not exceed 50° C. Heating devices installed inside the load compartments shall be designed so as to prevent the ignition of an explosive atmosphere under operating conditions.

5.4.2 **Additional requirements concerning the construction of the bodies of complete or completed vehicles intended for the carriage of dangerous solids in bulk.**

5.4.2.1 If the vehicle is intended for the carriage of dangerous and hazardous goods for which a label conforming to CMVR rules are provided, no fuel tanks, power sources, combustion air or heating air intakes as well as exhaust tube outlets required for the operation of the combustion heater shall be installed in the load compartment. It shall be ensured that the heating air outlet cannot be blocked by cargo. The temperature to which the load is heated shall not exceed 50°C. This will be inspected and approved by **PESO** or its authorised agency. Heating devices installed inside the load compartments shall be designed so as to prevent the ignition of an explosive atmosphere under operating conditions.

5.4.3 **Additional requirements concerning complete or completed vehicles intended for the carriage of temperature controlled**

self-reactive substances of class 4.1 and organic peroxides of class 5.2.

- 5.4.3.1 Insulated, refrigerated and mechanically-refrigerated vehicles intended for the carriage of temperature controlled self-reactive substances and organic peroxides shall conform to the following conditions :
- (a) the vehicle shall be such and so equipped as regards its insulation and means of refrigeration, that the control temperature prescribed for the substance to be carried is not exceeded.
 - (b) the vehicle shall be so equipped that vapours from the substances or the coolant carried cannot penetrate into the driver's cab.
 - (c) a suitable device shall be provided enabling the temperature prevailing in the loading space to be determined at any time from the cab.
 - (d) the loading space shall be provided with vents or ventilating valves if there is any risk of a dangerous excess pressure arising therein. Care shall be taken where necessary to ensure that refrigeration is not impaired by the vents or ventilating valves.
 - (e) the refrigerant shall not be flammable; and (f) the refrigerating appliance of a mechanically refrigerated vehicle shall be capable of operating independently of the engine used to propel the vehicle.
- 5.4.3.2 Suitable methods to prevent the control temperature from being exceeded should be provided. Depending on the method used, additional provisions concerning the construction of vehicle bodies may be adopted.
- 5.4.4 Additional requirements concerning fixed tanks (tank-vehicles) battery-vehicles and complete or completed vehicles used for the carriage of dangerous and hazardous goods in demountable tanks with a capacity greater than 1 m³ or in tank-containers, portable tanks or MEGCs of a capacity greater than 3 m³ (FL, OX and AT vehicles)
- 5.4.4.1 **General provisions :**
- 5.4.4.1.1 In addition to the vehicle proper, or the units of running gear used in its stead, a tank-vehicle comprises one or more shells, their items of equipment and the fittings for attaching them to the vehicle or to the running-gear units.
 - 5.4.4.1.2 Once the demountable tank has been attached to the carrier vehicle, the entire unit shall meet the requirements prescribed for tank-vehicles.
- 5.4.4.2 **Requirements concerning tanks :**

- 5.4.4.2.1 Fixed tanks or demountable tanks made of metal shall meet the relevant requirements laid down by the Petroleum and Explosives Safety Organisation (PESO).
- 5.4.4.3 **Fastenings** : Fastenings shall be designed to withstand static and dynamic stresses in normal conditions of carriage, and minimum stresses as defined in the case of tank-vehicles, battery-vehicles, and vehicles carrying demountable tanks.
- 5.4.4.4 **Earthing** : Earthing of FL vehicles Tanks made of metal or of fibre-reinforced plastics material of FL tank-vehicles and battery elements of FL battery vehicles shall be linked to the chassis by means of at least one good electrical connection. Any metal contact capable of causing electrochemical corrosion shall be avoided.
- 5.4.4.5 **Stability of tank-vehicles**
- 5.4.4.5.1 The height of the centre of gravity of the laden vehicle shall not exceed 90% of the overall width of the ground level bearing surface (distance between the outer points of contact with the ground of the right hand tyre and the left hand tyre of the same axle.
- 5.4.4.5.2 In addition, tank-vehicles with fixed tanks with a capacity of more than 3 m³ intended for the carriage of dangerous and hazardous goods in the liquid or molten state tested with a pressure of less than 4 bar, shall comply with the technical requirements of Section 8.0 of this code, for lateral stability, as amended, in accordance with the dates of application specified therein.
- 5.4.4.6 **Under run protection**
- 5.4.4.6.1 The rear under-run protection and lateral under-run protection devices shall be in accordance with IS 14812 and IS 14682 respectively as amended from time to time.
- Note 1:** This provision does not apply to vehicles used for the carriage of dangerous and hazardous goods in tank containers, MEGCs or portable tanks. Vehicles with a tilting shell for the carriage of powdery or granular substances and a vacuum operated waste tank with a tilting shell with rear discharge do not require a bumper if the rear fittings of the shell are provided with a means of protection which protects the shell in the same way as a bumper. These may be exempted where the device is incompatible to the end use.
- 5.4.4.7 **Combustion heaters**
- 5.4.4.7.1 Combustion heaters shall meet the following additional requirements
- (a) The switch may be installed outside the driver's cab
 - (b) The device may be switched off from outside the load compartment; and

- (c) It is not necessary to prove that the heat exchanger is resistant to the reduced after running cycle.

In addition for FL vehicles, they shall meet the following requirements :

- (i) The combustion heaters and their exhaust gas routing shall be designed, located, protected or covered so as to prevent any unacceptable risk of heating or ignition of the load. This requirement shall be considered as fulfilled if the fuel tank and the exhaust system of the appliance conform to provisions similar to those prescribed for fuel tanks and exhaust systems of vehicles in clause nos. 5.3.1.2.2 and 5.3.1.2.4.
- (ii) The combustion heaters shall be put out of operation by at least one of the following methods:
 - (a) Intentional manual switching off from the driver's cab;
 - (b) Stopping of the vehicle engine; in this case the heating device may be restarted manually by the driver;
 - (c) Startup of a feed pump on the motor vehicle for the dangerous goods carried.

5.4.4.7.2 After-running is permitted after the combustion heaters have been put out of operation. For the methods of 5.4.4.7.1, (ii), (b) and (c) the supply of combustion air shall be interrupted by suitable measures after an after-running cycle of not more than 40 seconds. Only heaters shall be used for which proof has been furnished that the heat exchanger is resistant to the reduced after-running cycle of 40 seconds for the time of their normal use.

5.4.4.7.3 If the vehicle is intended for the carriage of dangerous and hazardous goods for which a label conforming to CMVR is prescribed, no fuel tanks, power sources, combustion air or heating air intakes as well as exhaust tube outlets required for the operation of the combustion heater shall be installed in the load compartment. It shall be ensured that the heating air outlet cannot be blocked by cargo. The temperature to which the load is heated shall not exceed 50°C. Heating devices installed inside the load compartments shall be designed so as to prevent the ignition of an explosive atmosphere under operating conditions.

5.5 Manner of display of class labels and identification marks : The display of class labels shall be as per Rule 130 of Central Motor Vehicle Rules, 1989.

5.6 Essential equipment and documents to be carried in the vehicle :

5.6.1 The documents to be carried in the vehicle shall be as per the

requirements specified in Rules 131 to 136 of CMVR.

- 5.6.1.1 **Placarding and marking :** Transport units carrying dangerous and hazardous goods shall be placarded and marked in conformity with Central Motor Vehicle Rules, 1989 and **PESO** rules.
- 5.6.1.2 **Fire -fighting appliances.**
- 5.6.1.2.1 Every transport unit carrying dangerous and hazardous goods shall be equipped with fire extinguishers as per Petroleum rules or PESO 2002 published in 2012;
- (a) A portable fire extinguisher (10 kg. dry chemical powder or equivalent) suitable for extinguishing petroleum fire shall be carried in an easily accessible and detachable position and away from the discharge faucets on every vehicle transporting petroleum by road. Additionally, one dry chemical powder type fire extinguisher of 1 kg. Capacity shall be carried in the driver's cabin of the vehicle.
- (b) For vehicles of category EX (carrying explosives) – two fire extinguishers, one capable of dousing electrical fires and the other capable handling fires due to engine, tyres etc. This is as per Explosive Rules.
- 5.6.1.2.2 The extinguishing agents contained in the fire extinguishers with which a transport unit is equipped shall be such that they are not liable to release toxic gases into the driver's cab or under the influence of the heat of the fire.
- 5.6.1.2.3 The portable fire extinguishers conforming to the provisions above shall be fitted with a seal verifying that they have not been used. In addition, they shall bear a mark of compliance with a standard recognized by a competent authority and an inscription indicating the expiry date (month, year).
- 5.6.1.3 **Miscellaneous equipment :** Every transport unit carrying dangerous and hazardous goods shall be equipped with :
- (a) For each vehicle, at least one wheel chock, of a size suited to the weight of the vehicle and to the diameter of the wheels.
- The necessary equipment to take the general actions referred to in the safety instructions, in particular :
- (b)
- A suitable warning vest or warning clothing for each member of the vehicle crew.
 - A pocket lamp for each member of the vehicle crew.

- 5.7 Driver training requirements :** Driver training and licensing shall be as per Rule 9 of the Central Motor Vehicle Rules, 1989.
- 5.8 Periodic Inspection of vehicles :** The periodic inspection of the hazardous or dangerous goods carrying vehicles would be necessary with respect to the following.
- (i) Obtaining the fitness of the vehicle which is required yearly or a lesser period.
 - (ii) Inspection of the vehicle externally, internally and also by ultrasonic inspection.
 - (iii) Inspection of the vehicle for the **PESO** documents, emergency information panel, hazard class labels etc.
- 5.9 Type approval process :**
- 5.9.1 Approvals of PESO (Petroleum & Explosives Safety Organisation) for tankers / trailers :**
- 5.9.1.1 Tanker / Bullet :** The tanker manufacturer and / or the bullet manufacturer shall approach the Department of Explosives for the approval of the design and the prototype as per the existing procedure.
- 5.9.2 Vehicle type approval :**
- 5.9.2.1** The type approval of the basic vehicle chassis and bodies for vehicles and or trailers / semi-trailers will be carried out by the testing agencies specified in Rule 126 of Central Motor Vehicle Rules, 1989.
- 5.9.2.2** The vehicle manufacturer shall submit his application with all the necessary documents and also the documents with regard to its specific constructional features given at Annexure III of this code, to the testing agency for compliance to to this section in addition to the Central Motor Vehicle Rules, 1989 requirements.
- 5.9.2.3** A vehicle representative of the type to be approved shall be submitted to the testing agency responsible for conducting the approval tests. However it can be only chassis as the body and installations are approved by **PESO**.
- 5.9.2.4** The testing agency shall issue type approval for the basic vehicle after verifying all the necessary compliance requirements stated in Central Motor Vehicle Rules, 1989 and the provisions stated in this section.

5.9.3 Vehicle registration :

5.9.3.1 The integrated process of vehicle registration will be carried out by the registering authorities after necessary verification of the documents of vehicle approval and the tanker / bullet approval by **PESO** or their authorised third party evaluators.

5.9.3.2 The system of vehicle registration for dangerous and hazardous goods carrying vehicles are as indicated in the flow chart below.

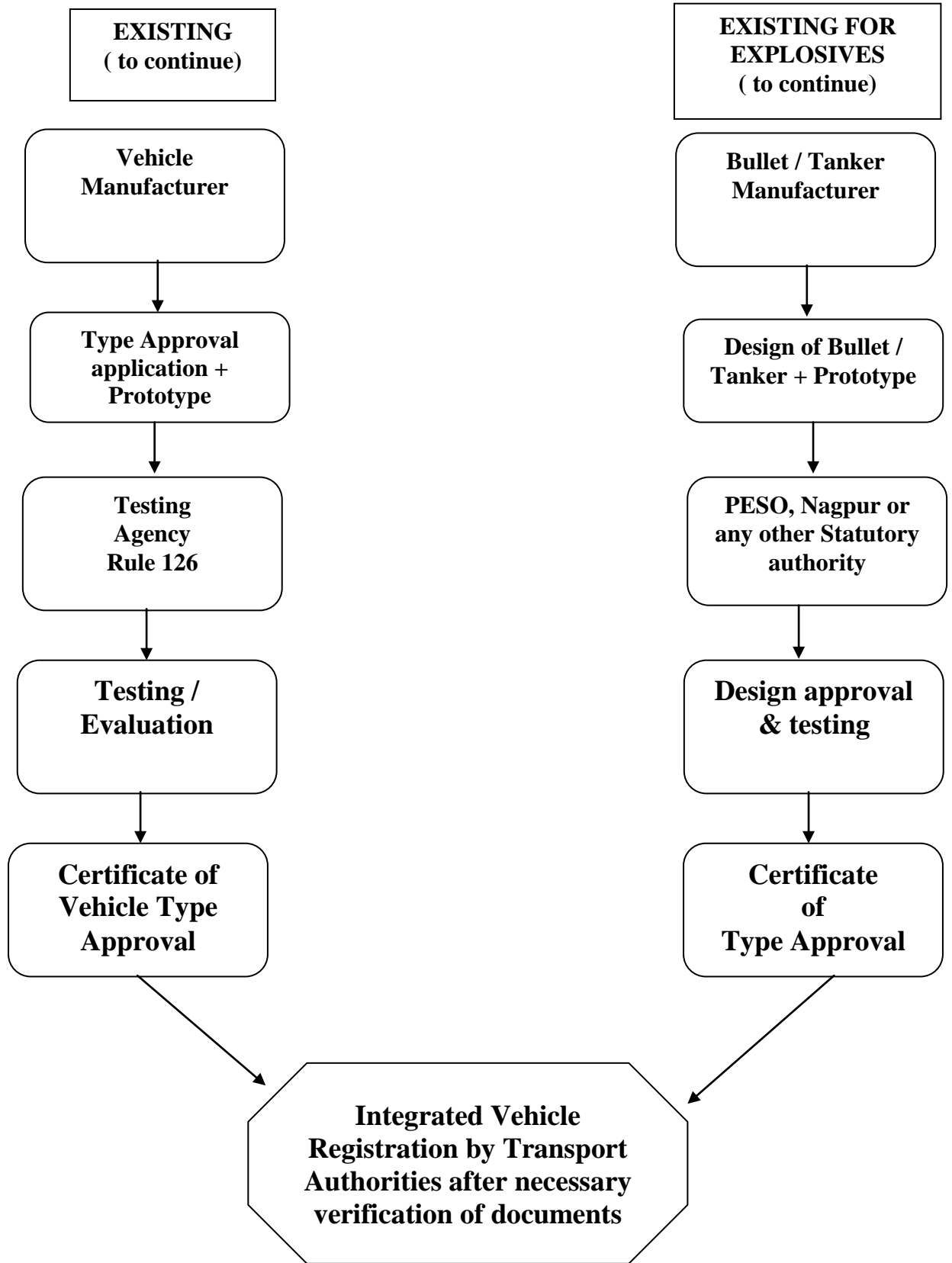

Flow chart of Vehicle Registration

SECTION - 6.0**REQUIREMENTS OF CONTAINER CARRIERS AND TANKERS****LIST OF CONTENTS**

6.1	Scope
6.2	Definitions of Freight Container
6.3	Container Types
6.4	Container Size Designations and Sizes Codes
6.5	Recommendations for Stacking of Load
6.6	Twist Locks
6.7	Container securing arrangements
6.8	Attaching Sub-frames and Bodies
6.9	Tanker Mounting

6.1 SCOPE :

This section would apply to all containers used for the transport of goods by road vehicles which are generally of the type 1AAA, 1AA, 1AX etc.

6.2 Definition of Freight Container : Freight container is an article of transport equipment,

- i) of a permanent character and accordingly strong enough to be suitable for repeated use.
- ii) Specially designed to facilitate the carriage of goods by one or more modes of transport, without intermediate reloading of the goods.
- iii) Fitted with devices permitting its ready handling, particularly its transfer from one mode of transport to another.
- iv) So designed as to be easy to fill and empty.
- v) Having an internal volume of 1m³ or more.

The term freight container includes neither vehicles nor conventional packing. Freight containers coding, Identification, and marking shall be as per IS : 6928 -2001.

6.3 Container types : Typical container types are grouped in **Table-1**, and groups are subdivided according to the following concepts,

- mode of transport,
- categories of cargo and
- physical characteristics of the container.

General cargo containers include those containers, which are not specifically or primarily intended for a particular category of cargo. This group is sub-divided according to type of structure and/or means of access for loading (packing) and emptying. Specific cargo containers include those for cargoes, which are temperature sensitive, for liquids and gases, for dry solids in bulk and for particular categories such as automobiles (cars), or livestock. This group is subdivided according to the appropriate physical attributes of the container such as ability to maintain a particular temperature under stated conditions, test pressures, etc.

6.3.1 General cargo containers: This is a general term applicable to any type of container which is not intended for use in air mode transport and which is not primarily intended for the carriage of a particular category of cargo requiring temperature control, a liquid or gas cargo, dry solids in bulk or cargoes such as automobiles (cars) or livestock.

- 6.3.2 **General purpose containers:** Freight container, totally enclosed and weather proof having a rigid roof, rigid side walls, rigid walls and a floor, having at least one of its end walls equipped with doors and intended to be suitable for the transport of cargo of the greatest possible variety. General cargo container for general purposes shall meet requirements of IS:13288 (Part1) - 1993.
- 6.3.3 **Specific purpose container:** This is a general term applicable to all general cargo containers having constructional features either for the “special purpose” of facilitating packing and emptying other than by means of doors at one end of the container, or for other specific purposes such as ventilation.
- 6.3.4 **Closed ventilated container:** Container of a closed type, similar to a general purpose container, but specifically designed for carriage of cargo where ventilation, either natural or mechanical is necessary.
- 6.3.5 **Open top container:** Freight container similar in all respects to a general purpose container except that it has no rigid roof but may have flexible and movable or removable cover, for example one made of canvas or plastic or reinforced plastic material normally supported on movable or removable roof bows. Such containers may have movable or removable top end transverse members above their end doors, as shown in Figure – 6.
- 6.3.6 **Platform based container open sided:** This is a general term applied to any general cargo container which does not have rigid side walls or equivalent structures capable of withstanding all of the loads that may be withstood or transmitted by a side wall of a general purpose container and which, for this reason, has a base structure similar to that of a platform. Platform based containers , as shown in Figure 4 and 5, shall comply the requirements of IS 13288 (Part5) - 1992.
- 6.3.6.1 **Platform based container open sided with complete superstructure:** Platform based container, having a permanently fixed longitudinal load carrying structure between end at the top.
- Note:** The term “load” as used refers to a static/dynamic type load, not a cargo load.
- 6.3.6.2 **Platform based container with incomplete superstructure and fixed ends :** Platform based container without any permanently fixed longitudinal load carrying structure between ends other than at the base.
- 6.3.6.3 **Platform based containers with incomplete superstructure and folding ends :** Platform based container with incomplete superstructure but having folded end frames with a complete transverse structural connection between corner posts.

- 6.3.7 **Platform container** : Loadable platform having no superstructure whatever but having the same length and width as the base of a container of the same series and equipped with top and bottom corner fittings, located in the plan view as on containers of series 1, so that some of the same securing and fitting devices can be used.
- 6.3.8 **Specific cargo containers** : This is a general term applied to those types of containers, which are primarily intended for the carriage of particular categories of cargo.
- 6.3.9 **Thermal container** : Freight container built with insulating walls, doors, floor and roof which retard the rate of heat transmission between the inside and the outside of the container. Thermal containers shall meet the requirements of IS:13288 (Part2) 1993.
- 6.3.10 **Insulated container** : Thermal container with the use of devices for cooling and / or heating.
- 6.3.11 **Refrigerated container (expendable refrigerant)** : Thermal container using a means of cooling such as ice, dry ice, with or without sublimation control, or liquefied gases, with or without evaporation control. It is implicit in this definition that such a container requires no external power supply or fuel supply. Refrigerated containers are as shown in Figure 1 and Figure 2.
- 6.3.12 **Mechanically refrigerated container** : Thermal container served by refrigerating appliance (mechanical compressor unit, absorption unit, etc).
- 6.3.13 **Heated container**: These are thermal container served by heat producing appliance.
- 6.3.14 **Refrigerated and heated container** : Thermal container served by refrigerating appliance (mechanical or expendable refrigerant) and heat producing appliance.
- 6.3.15 **Tank Container** : A freight container which includes two basic elements, the tank or tanks and frame work, and complies with the requirements of IS:13288 (Part 3) - 2002 as shown in Figure – 3.
- 6.3.16 **Terminology of Tank Containers** :
- 6.3.16.1 **Frame work**: The tank mountings, end structure and all load bearing elements not present for the purposes of containing cargo, which transmit static and dynamic forces arising out of the lifting, handling, securement and transporting of the tank container as a whole.
- 6.3.16.2 **Tank or tanks**: The vessel or vessels, and associated piping and fittings which are designed to confine the goods carried.

- 6.3.16.3 **Compartment:** Any fluid-tight section of the tank formed by the shell, ends or bulkheads. It should be noted that baffles surge plates to other perforated plates do not form tank compartments within the meaning of this definition.
- 6.3.16.4 **Dry bulk container :** Container consisting of a cargo-carrying structure, firmly secured within an ISO series 1 frame work, for the carriage of dry solids in bulk without packaging.
- 6.3.16.5 **Named cargo types:** Various types of containers such as automobile car) containers, live stock containers and others, are built in general accordance with ISO container requirements either solely or primarily for the carriage of a named cargo.
- 6.4 Container size designations and sizes codes :**
- 6.4.1 Series 1 containers, are intended for intercontinental use. For series 1 containers, the size designations are given in the attached Table-1.
- 6.4.1.1 **Container size codes :** The size codes of the containers shall be as per IS:6928:2001. Normally the size code consists of two Arabic numerals. For containers having a nominal length equal to or greater than 3000 mm, the first numeral denotes length and the second numeral denotes height and the presence or absence of a gooseneck tunnel.
- 6.4.2 **Definitions related to Dimensions and Capacities :**
- 6.4.2.1 **External dimensions :**
- 6.4.2.1.1 **Nominal dimensions :** Nominal dimensions are those dimensions, neglecting tolerances, and rounded to the nearest convenient figure, by which a container may be identified.
- 6.4.2.1.2 **Actual dimensions :** These are maximum overall dimensions (including positive tolerances where these are applicable) for length, width and height measured along the exterior edges of the container.
- 6.4.2.1.3 **Note :** Diagonal tolerances, applicable to any of the six “faces” of a container are expressed in terms of the allowable differences between the lengths of the diagonal (measured between the centers of the corner fitting apertures) of the face in question. These diagonal tolerances are allowable even when the edge dimensions for the surface in question are at their maximum values.
- 6.4.2.1.4 **Internal dimensions :** These are the dimensions of the largest unobstructed rectangular parallelepiped, which could be inscribed in the container if inward protrusions of the top corner fittings are neglected. Except where otherwise stated, the term “internal dimensions” is synonymous with the term “unobstructed internal dimensions”.

- 6.4.2.1.5 **Door opening** : This term is usually reserved for the definition of the size of the door aperture, i.e. the width and height dimensions of the largest unobstructed parallelepiped, which could possibly be entered into the container via the door aperture in question. Minimum door openings of the container shall be as per IS 13288 (Part1): 1993 and IS 13288 (Part2): 2001.
- 6.4.2.1.6 **Internal volume** : Volume determined by multiplying the internal dimensions, i.e. the product of internal length, width and height. Except when otherwise stated the term “internal volume” is synonymous with the terms “unobstructed internal volume”, “capacity” or “unobstructed capacity”.
- 6.4.3 **Definitions related to the Rating and Masses :**
- 6.4.3.1 **Rating (R)** : This is the maximum permissible combined mass of the container and its contents, i.e. the maximum operating gross mass. Rating shall follow the IS:6566 - 2001.
- 6.4.3.2 **Tare mass (T)** : The mass of empty container including all fittings and appliances associated with a particular type of container in its normal operating condition, i.e. in the case of a mechanically refrigerated container; with its refrigeration equipment installed and, where appropriate, full of fuel.
- 6.4.3.3 **Pay load (P)** : Maximum permitted mass of pay load (including such cargo securement arrangements and / or dunnage as are not associated with the container in its normal operating conditions). Pay load is calculated by subtracting the tare mass from rating ($P = R - T$).
- 6.4.4 **General** : When being transported by road containers are subjected to forces and vibrations arising from braking, shunting, cornering, acceleration, road surface and wind. Securing methods should take these factors and those factors identified in 9.1 into account. For road transport the container shall not project beyond the front *or rear* of the carrying vehicle. The ISO standards related to Containers are as given in the following Table-2 for reference and guidelines.

Table 2
ISO Standards Related to Containers

Sr. No	ISO Standards	Description
1	ISO 688: 1995	Series 1 Frieght Containers – Classification, dimensions and ratings
2	ISO 830: 1999	Frieght Containers – Vocabulary
3	ISO 1161:1984	Frieght Containers – Corner Fittings Specification

4	ISO 1496-1:1990	Frieght Container – Specification and Testing General Cargo Containers for General Purposes
5	ISO 1496-2: 1996	Frieght Container – Specification and Testing Thermal Containers
6	ISO 1496-3:1995	Frieght Container – Specification and Testing Tank Containers for liquids, gases and pressurized dry bulk
7	ISO 1496-4:1991	Frieght Container – Specification and Testing Non Pressurised container for dry bulk
8	ISO 1496-5: 1991	Frieght Container – Specification and Testing Platform and Platform based containers
9	ISO 3874: 1997	Frieght containers Handling and Securing
10	ISO 6346: 1995	Frieght Containers – coding, identification and marking
11	ISO 8323: 1985	Frieght Containers – Air /surface (intermodal) general purpose Containers – Specification and tests

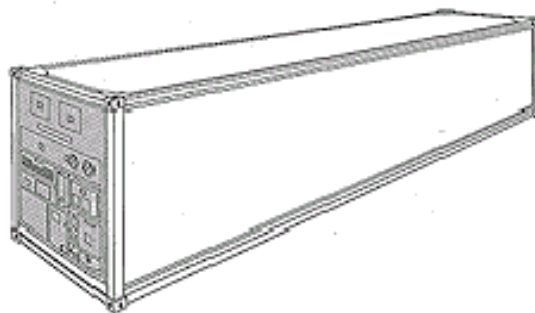

**Figure 1
Refrigerated Container**

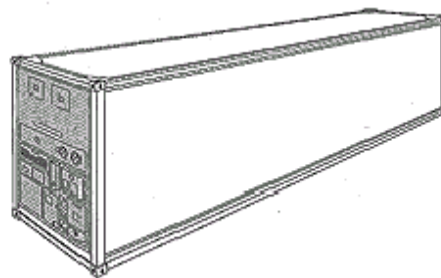

**Figure 2
High Cube Refrigerated Container**

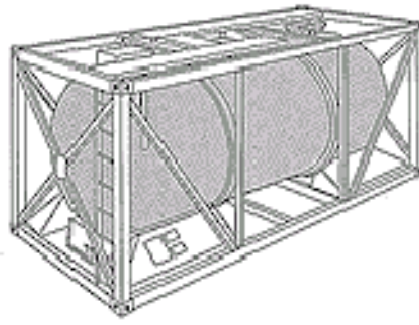

Figure 3
Tank Container

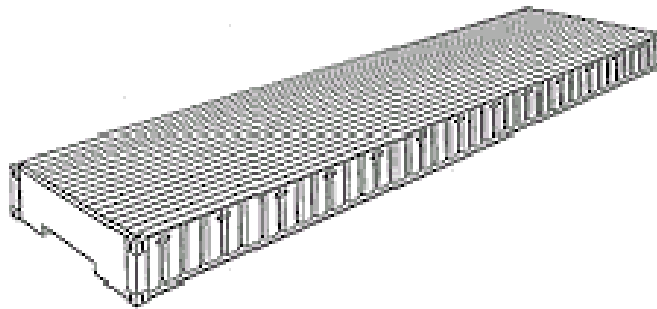

Figure 4
Platform Based Container

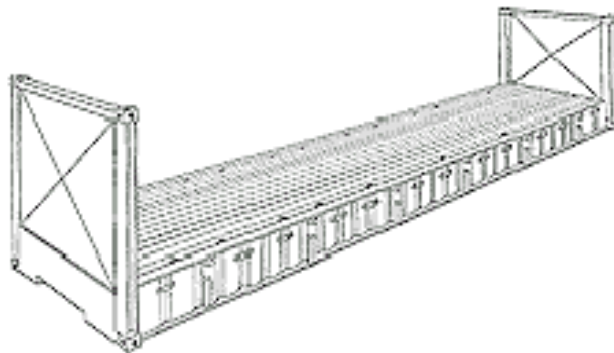

Figure 5
Flat Rack Container

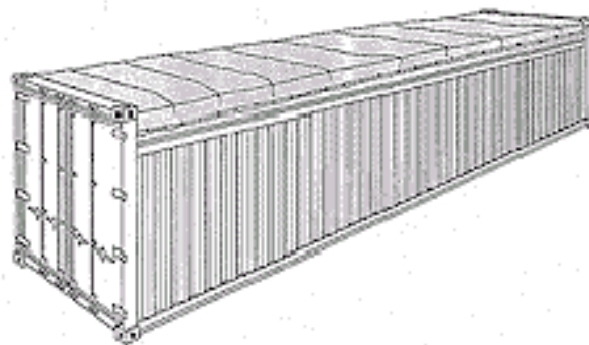

Figure 6
Open Top Container

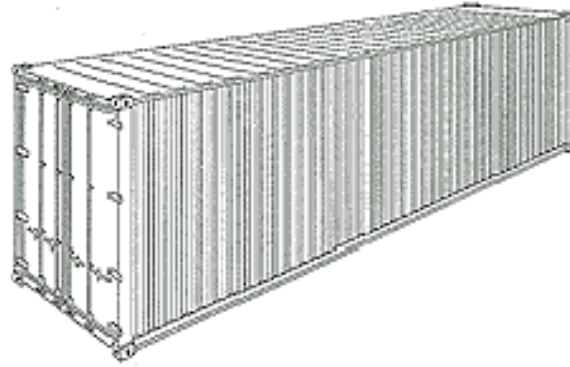

Figure 7
High Cube Container

6.5 Recommendations for Stacking of Load :

6.5.1 Loads :

The load stacked in vehicles must be secured for protection against the following motions during transport.

- Impact against loading docks
- Braking and acceleration
- Sway on curves
- Coupling impact
- Vibration and shocks

6.5.2 Loading pattern : Loading pattern should be planned for each commodity prior to loading to avoid overloading at any one end.

6.5.3 Loading intensity : Maximum permissible intensity of loading shall not exceed

- For 20-ft container 4.5 ton/m²
- For 40-ft container 3 ton/m²

6.5.4 Centre of gravity : Heavy goods should not be placed on top of the lighter goods. The center of gravity be maintained in lower half of the height. Longitudinally, the centre of gravity shall not be out of the middle by following limits:

- 20-ft container 0.6 m on both sides
- 40-ft container 0.9 m on both sides

6.6 Twist locks : Twist locks shall be provided to hold the containers safely and rigidly on the load body platform of the vehicle, or on the base of a trailer / semi-trailer. These twist locks shall comply with the requirements specified in IS: 7622 – 2001.

6.6.1 Design dimensions of twist locks :

6.6.1.1 Top and bottom cone : In fully locked position, load carrying area must be larger than 800 mm². Top and bottom shall not protrude into part of the corner cavity that is required for other lashing equipment.

- 6.6.1.2 **Intermediate plate** : The thickness of the intermediate plate may be between 29.5 and 30 mm. The load carrying area (flange surface bearing area) of intermediate plate may be at least 4500 mm^2 . It shall be so designed as to have maximum load transfer area towards walls of corner fittings. A typical construction is shown in Figure 8.

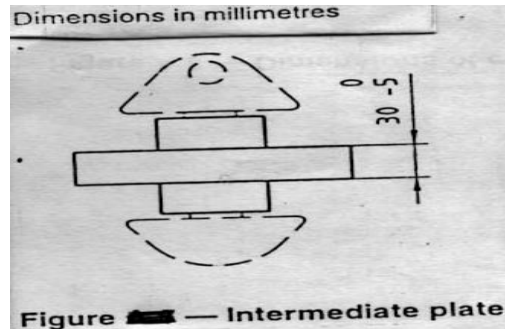

Figure- 8
Intermediate Plate

- 6.6.1.3 **Handle** : The length of handle measured from centerline of locks to the end may be maximum 160 mm. The bent up tail of handle shall have a length of $25 \text{ mm} \pm 2 \text{ mm}$. A typical construction is shown in Figure 9.

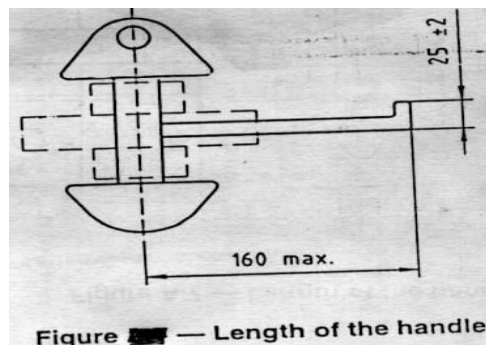

Figure - 9
Length of the Handle

- 6.6.1.4 **Distance between top and bottom locks** : The distance between top and bottom locks should be at least the actual thickness of intermediate plate plus 2 times $(33 \pm 1) \text{ mm}$.
- 6.6.1.5 **Collar** : In order to fit into corner fitting pertures, the collar may have dimensions as shown in Figure 10.

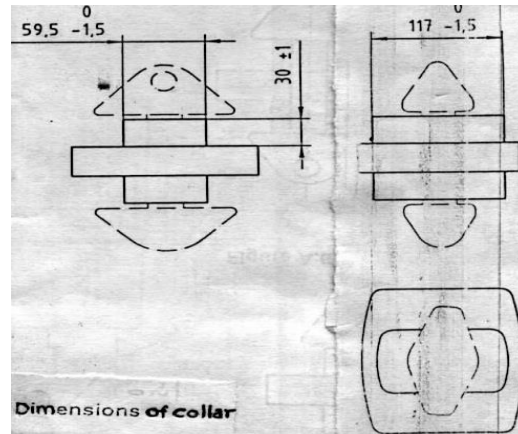

Figure-10
Dimensions of the Collar

6.6.2 Performance specifications :

6.6.2.1 **Tensile strength** : Twist locks shall withstand a tensile force of 150 kN without any permanent deformation.

6.6.2.2 **Compression strength** : The intermediate plate of the twist lock shall withstand a compression force of 850 kN without any permanent deformation or rendering unsuitable for use. The cones of twist locks shall withstand a compression force of 150 kN without any permanent deformation.

6.6.2.3 **Shear strength** : The collars of twist lock shall withstand a shearing force of 300 kN longitudinally and transversally without permanent deformation or rendering unfit for use.

6.7 Container securing arrangements

6.7.1 **Four twist lock system** : Nominal centre-to-centre distances for positioning twist lock collars will be identical to corresponding dimensions measured between centre points of bottom holes in the bottom corner fittings of the container, and are given below. The nominal centre-to-centre distances for positioning of twist lock collars are as indicated in Table-3 below

Table 3
Nominal Center to Center Distances

Container designation	Longitudinal distance	Lateral distance
1AA/1A/1AX	11985.5	2259
1BB/1B/1BX	8918.5	2259
1CC/1C/1CX	5853.5	2259
1D/1DX	2787	2259

- 6.7.2 **Tolerances** : Tolerance (Tst) on longitudinal centre-to-centre distance between collars and the Tolerance (Tpt) on lateral centre-to-centre distance between collars are as indicated in the Table-4 below. The twist lock collar sizes are as indicated in Table-5.

Table 4
Lateral Centre-to-Centre Distance between Collars

For collars for containers of designation -	Tst			Tpt			Allowable diagonal difference, k		
	Collar size			Collar size			Collar size		
	A	B	C	A	B	C	A	B	C
1AA/1A/1AX	± 2.5	± 3.5	± 4.5	± 2	± 3	± 4	± 4.5	± 8.5	±10.5
1BB/1B/1BX	± 2.5	± 4.5	± 5.5	± 2	± 3	± 4	± 7	± 9	± 11
1CC/1C/1CX	± 4.0	± 5.5	± 7.0	± 2	± 3	± 4	± 10	± 13	± 14
1D/1DX	± 4.0	± 5.5	± 7.0	± 2	± 3	± 4	± 10	± 12.5	±13.5

Table 5
Twist Lock Collar Sizes(in mm)

Size	Length (or Diameter)	Width
A	100	57
B	97	56
C	95	55

- 6.7.3 **Two pins and two twist locks:** In cases where the vehicle is a semi-trailer with a gooseneck, it is a common practice to arrange for one end of the container (gooseneck tunnel end) to be secured by means of pins engaging the end holes of the corner fittings adjacent to the tunnel and to arrange for the other end to be secured by means of twist lock. The dimension of the gooseneck chassis are as indicated in Table-6 below.

These are commonly used for 1AA, 1A and 1AX containers.

Table 6
Dimensions of Gooseneck Chassis.

Container Designation	Container Size	L	K max
1AA/ 1A/ 1AX	12 192	12 098 ± 6	16
1BB/ 1B/ 1BX	9 125	9 030 ± 6	13
1CC/ 1C/ 1CX	6 058	5 962 ±6	10

In the above figure,
P (Pin penetration) = 32 min.
E (Pin extension) = 67 min.

6.7.4 **Terminal trailer operation:** Terminal trailer operation in this context is container movement on terminal trailers at low speed over short distances within designated areas. For such operation, tie-down devices are not required but the container shall be correctly located on the trailer and prevented from moving horizontally; that is generally achieved by ‘gathering guides’ or similar devices as in Figure - 11.

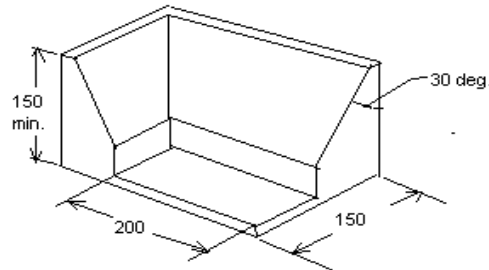

Example of gathering guide

Figure -11
Gathering Guide

6.8 **Attaching sub-frames and bodies :** Sub-frame and vehicle frame are to be joined using either a thrust-compliant or thrust-resistant arrangement. Depending on the body situation, it is possible, or even necessary, to have both types of joint at the same time (this is then referred to as partially thrust-resistant and the length and range of the thrust-resistant connection are given). The usage of these joints is determined based on their strength. Thrust-resistant connections are to be used if a thrust-compliant connection is no longer sufficient. A check must be made to see whether mounting brackets are strong enough when work implements and machines, lifts, tanker bodies etc., are installed.

6.8.1 **Flexible shim :** Wooden inserts and resilient shims, are not permitted to be used in combination. However, they can be used independently.

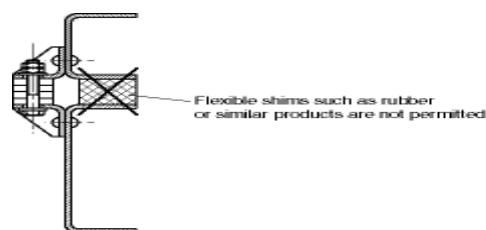

TDB-026

Figure-12
Flexible Shim

6.8.2 **Thrust-compliant connections** : Thrust-compliant connections are non-positive /frictional connections. Relative movement between frame and sub frame is possible to a limited degree. All bodies or sub frames that are bolted to the vehicle frame by means of mounting brackets are thrust-compliant connections. For a thrust-compliant connection the mounting points located on the chassis must be used first. These are not sufficient or cannot be used for design reasons, then the additional mountings are to be located at suitable points as per manufacturers instructions only. When selecting the number of mountings, ensure that the distance between the mounting point centres does not exceed 1200 mm (see Figure - 13 below).

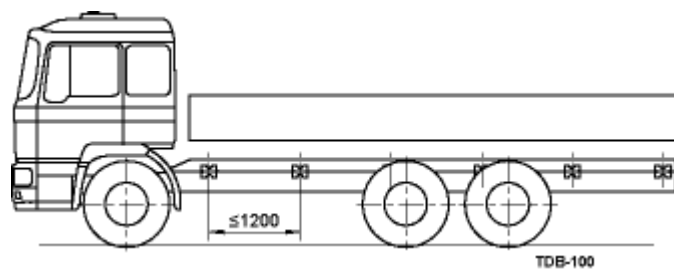

Figure -13
Distance between Sub-frame and Body Mountings TDB-100

6.8.3 **Clearance between brackets and frames** : The different clearances (gaps) between the mounting brackets and the frame and sub frame are compensated for by inserting shims of appropriate thickness as shown below in Figure-14 to Figure -21. The shims must be made of steel. Grade S235JR (=St37-2) is sufficient. Avoid having more than four shims at any one mounting point.

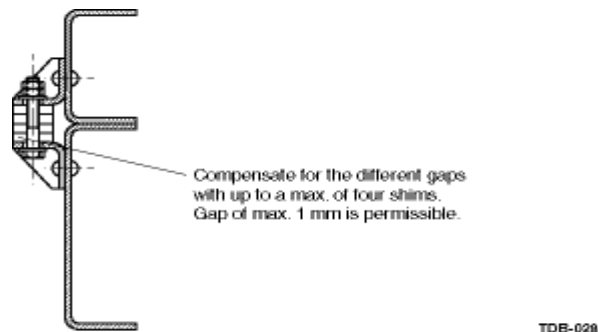

Figure-14
Shims between Mounting Brackets

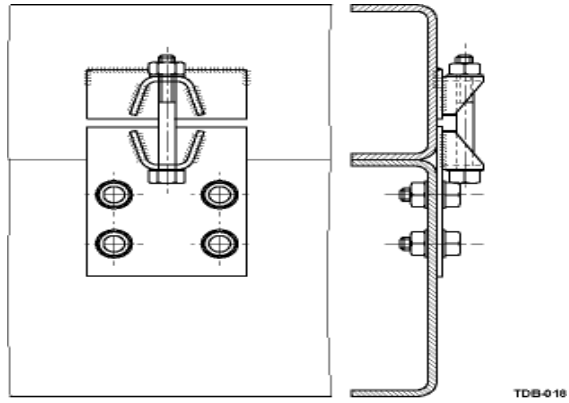

Figure-15
Mounting Bracket for Long Bolts

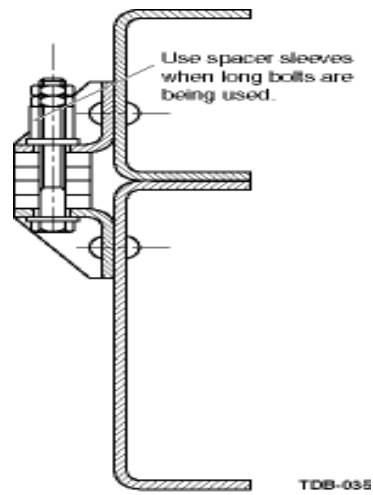

Figure-16
Spacer Sleeves for Long Bolts

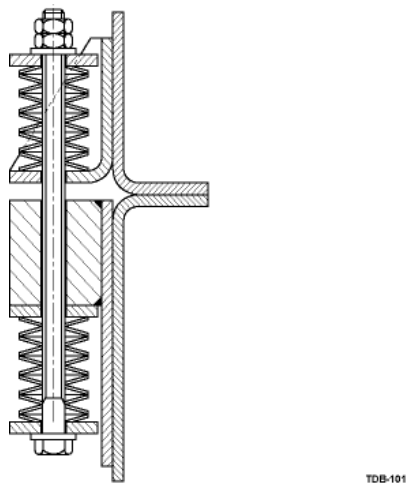
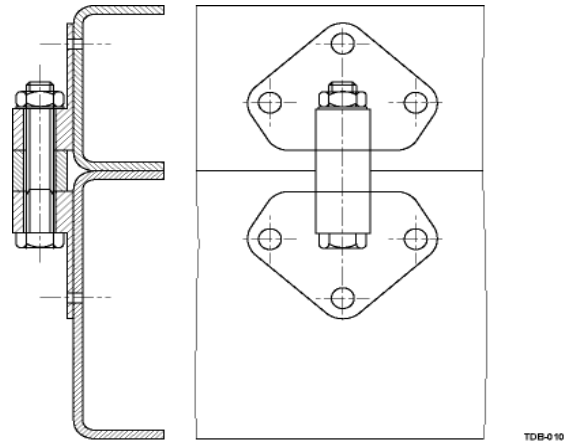
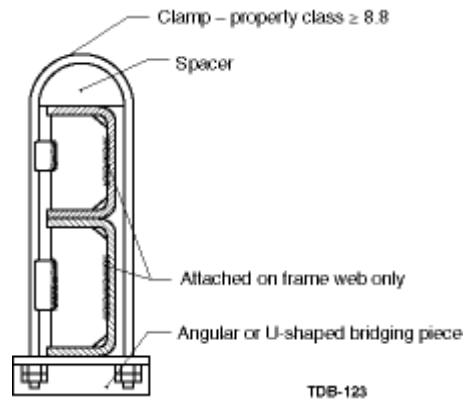

Figure-17
Long Bolts and Cup Springs



TDB-010

Figure-18
Sub-frame Mounting with Brackets



TDB-123

Figure-19
Shackle Mounting

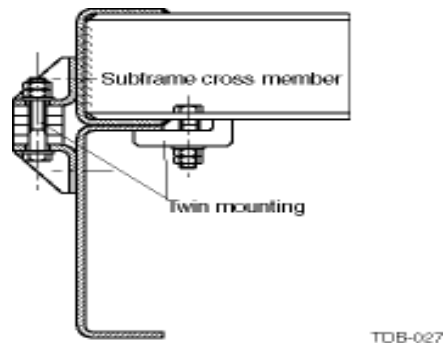

TDB-027

Figure-20
Twin Mounting

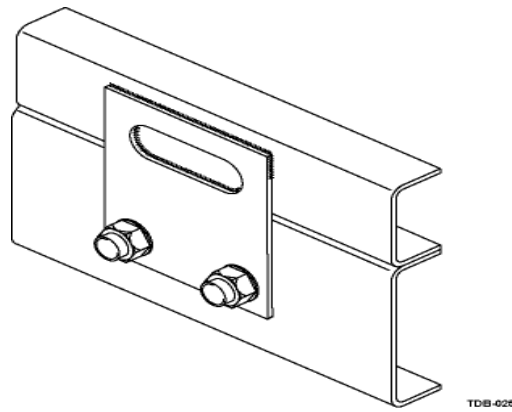

Figure-21
Twin Mounting with Plug Weld

6.8.4 **Self-supporting bodies without sub frame** : A sub frame is not required if ;

- there is a sufficient moment of resistance (affects the bending stress)
- there is a sufficient geometrical moment of inertia (affects flexing).

If the body is self-supporting and no point loads and rear loads (e.g. lift gate, trailer nose weights) occur, then in some circumstances a sub frame does not need to be fitted if the distance between the body cross members is not more than 600 mm as shown in Figure-22 below. This value of 600 mm may be exceeded only in the area of the rear axles.

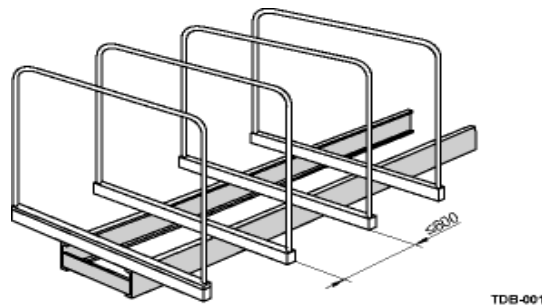

Figure-22
Distances between Cross Members when there is no Sub frame

The supports on the frame must be of the minimum lengths, as calculated using "Hertzian surface pressure". Here, "linear contact of two cylinders" is assumed rather than "linear contact of a cylinder and a plane". The Figure-23 below shows an exaggerated deformation of two U-sections lying on top of each other.

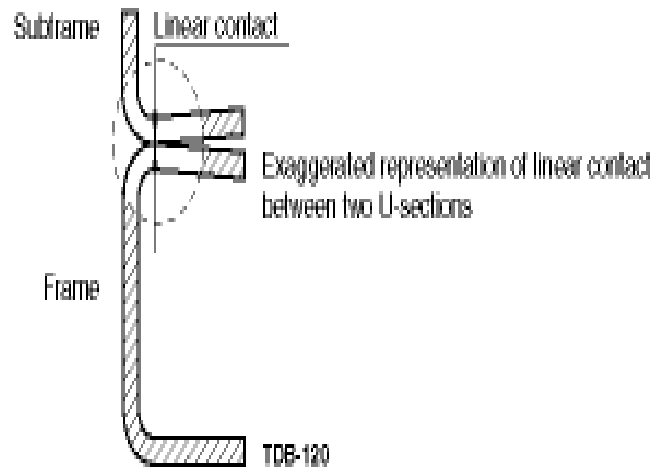

Figure-23
Deformation of Two U-sections

6.9 Tanker mounting :

6.9.1 **General requirements :** The mounting of tanker bodies is the most specialized of all equipment mountings because a stiff body can easily create local high stress points on the chassis frame. It is essential that this construction be allowed to float on the chassis and that chassis flexibility is not affected. Flexible mountings must be superimposed between tanker and chassis frame, as stipulated.

6.9.2 Mounting conditions :

6.9.2.1 Greater strengthened wider brackets to be used.

6.9.2.2 The vertical face of bracket must extend to the full depth of the chassis web. Otherwise an oil-can effect on chassis member may cause cracking of chassis web at lower edge of the bracket.

6.9.2.3 Brackets should not be welded to side member. No holes should be drilled on the top / bottom flange of the chassis.

6.9.2.4 All the brackets should be attached to the frame by fixing bolts with locknuts or nuts and heavy duty stocking spring washers.

6.9.2.5 Simple methods of resilient mounting can be adapted on a vehicle where the tank is able to flex to a degree without affecting the structure as shown in Figure-24.

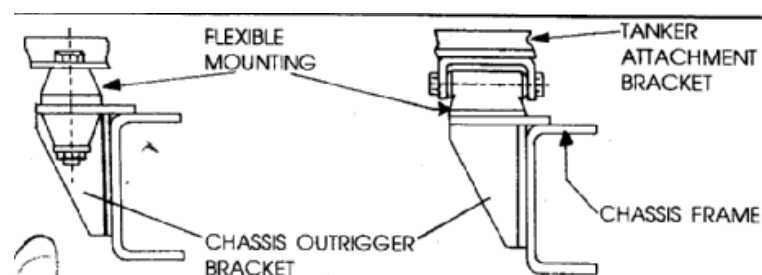

Figure-24
Flexible Mounting used in Tanker Application

6.9.2.6 Allowances to be made for variation in deflection on the road spring to avoid drainage sump / pipings of the tank fouling with air pipings and other chassis equipments.

6.9.2.7 The CG of all installations should be kept as low as possible.

6.9.2.7.1 Guidelines for calculation of CG height :

The general procedure to calculate CG height of the tanker is given below for guidance only.

- Location of CG height under unladen condition with 10.00 x 20 tyres

Description	Weight in kg	CG height from the ground in m	Moment in kgm
Cab	450	1.410m	634.5 kgm
Engine	546	1.008m	550.37 kgm
Gear box	135	0.727m	98.15 kgm
Front axle	500	0.508m	254.0 kgm
Rear axle	940	0.508m	447.00 kgm
Frame & misc	1830	0.887m	1623.2 kgm
	4401	--	3607.22 kgm

- Location of CG Ht. Of unladen chassis + cab from ground level $3607.22 / 4401 = 0.8196m$
- Location of CG height under laden condition with 10.00 x 20 tyres

Description	Total wt. in kg	CG height from the ground, m	Moment in kgm
Chassis + cab	4401	0.746	3283.12
Tank + payload + canopy + pipping	11490	2.185	22116.57
Sub frame	280	1.023	286.44
	16171	--	25686.13

- Location of CG of laden chassis $25686.13 / 16171 = 1.588m$

6.9.2.8 Another important parameter to be considered while building tanker is stability ratio. It should never be more than one. The usual recommended stability ratio is 0.7 to 0.9.

The stability ratio can be calculated as below : (Under normal spring deflection of 80 mm)

$$\begin{aligned} \text{Stability ratio} &= 2h \times \tan 28^\circ / b \\ h &= \text{CG ht. Under laden condition} \\ b &= \text{Rear outer tyres center distance} \\ &\text{in m} \\ \text{Stability ratio} &= \text{moment W.R.T. ground} / b \end{aligned}$$

6.9.2.9 **Spacing between mounting** : Brackets along the side of frame so that there is a mount adjacent to each rear axle spring bracket and a mount at the front of the tank as shown in Figure-25, below. Care must be taken that movement of rear axle is not restricted in any way. This is preferred on tankers operating on / off road, rural delivery.

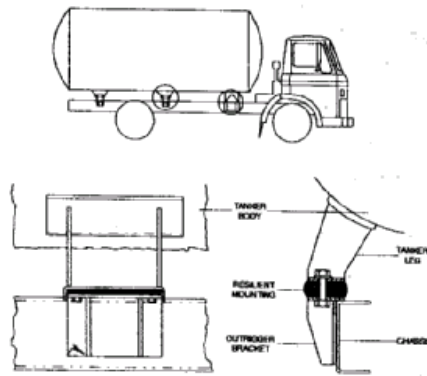

Figure-25

Arrangement of Rear Mounting and Spacing of Mounting

6.9.2.10 A greater relative movement between tank and frame can be achieved by incorporating coil springs between the tanker mounting feet and the front mounting brackets as shown in Figure-26.

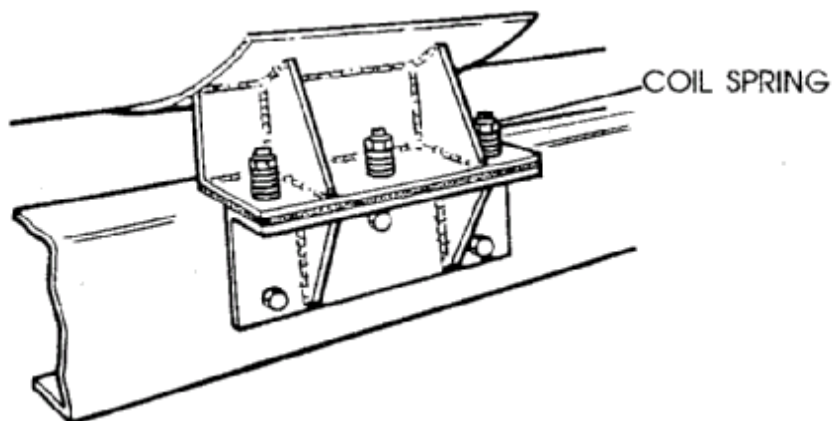

Figure-26

Arrangement of Front Mounting with Coil Springs

Alternatively, trunnion type of front mounting can also be tried. In this case, rear most bracket must be fastened rigidly by bolts, giving a positive constraint between body and chassis during acceleration, road movement, cornering and braking as shown in Figure-27.

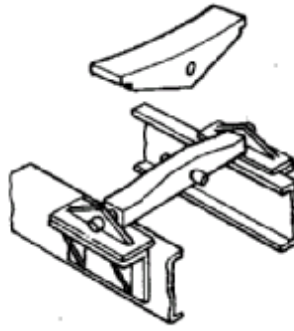

Figure-27

Preferred Arrangement of Front Mounting with Trunnion

6.9.2.11

Alternatively “U” bolts / fish plates arrangement with full length body runner as described in the earlier chapter can be fitted as shown in Figure-28. The typical “U” bolt arrangement for a milk tanker with integral tapered runner is shown in following Figure-29. In the tanker is to carry inflammable liquids or gases, petroleum regulations are to be followed. Depending upon the substances being carried, some of the equipments / points have to be fitted / followed as per Schedule (iii) of the Petroleum rules 1976, Rules No. 71 of Petroleum Rule 1976 and Rule No. 71 of 1937.

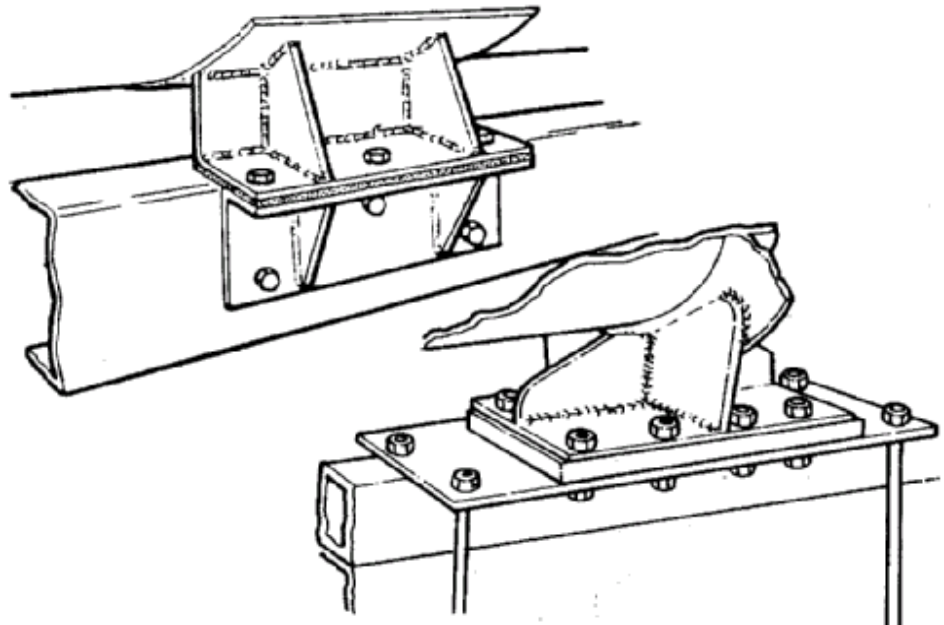

Figure -28

General Method of Tank Mountings

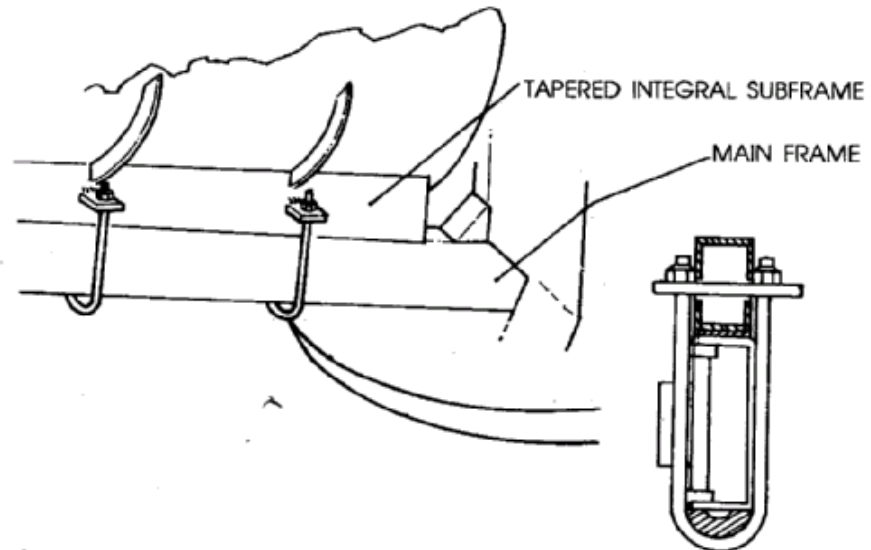

Figure 29
Typical "U" Bolt Arrangement Fitted on Milk Tanker

- Insulated return wiring.
- A battery master switch and batteries enclosed inside the cab.
- A fire screen.
- An exhaust system wholly ahead of fire screen with flame trap or spark arrester.
- Positively retained wired glass or planks for all rear ward facing cab windows.
- Fire extinguishers – foam type.

6.9.3 Other requirements for body fixtures and mountings :

Tank and container bodies require a continuous sub frame, yield point $\geq 0.2 > 350 \text{ N/mm}^2$. The connection between the body and chassis in the front area must be designed so that it does not excessively hinder the frame's ability to twist. This can be achieved by having front mountings that are as torsionally compliant as possible, e.g. by having

- Pendulum-type mounting as shown in Figure-30.
- Flexible mounting as shown in Figure-31.

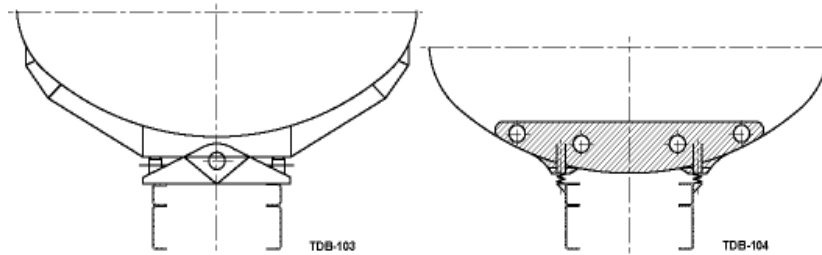

Figure - 30
Front Mounting as a Pendulum
Mounting

Figure - 31
Front Mounting as a Flexible
Mounting

The front mounting point should be as close as possible to the front axle center line as shown in Figure-31 and Figure-32. The rear, laterally stiff body support must be fitted in the area of the theoretical rear axle center line. There should also be a sufficiently large connection to the frame at this point. The distance between the theoretical rear axle center line and the centre of the support must be < 1000 mm as shown in Figure-31 and Figure-32.

- 6.9.4 **Layout of tanker and bulk container mountings** : After installing the body it is important that a check be made to see if vibrations or other disadvantageous properties are noticeable. Vibration can be influenced with the correct design of sub frame and the correct layout of the tanker mountings.
- 6.9.5 **Tankers and container bodies without sub-frames** : Tanker and container bodies without sub frames can be approved if the conditions described here are observed and there are double or triple mountings on each side of the frame. All supports must be arranged at the specified distances as shown in Figure-32 and Figure-33. If the permissible range is exceeded, this may cause the frame to bend excessively, which is not permitted; a continuous sub frame would then be required as shown in Figure 33. After installing the body it is important that a check be made to see if vibration or other disadvantageous properties are noticeable. The Table-7, given below would indicate the details of chassis without sub-frames for tanker bodies with double and triple mountings. The mounting arrangement of tankers is also shown in Figure-34 to Figure-37, which may be taken as general guidelines.

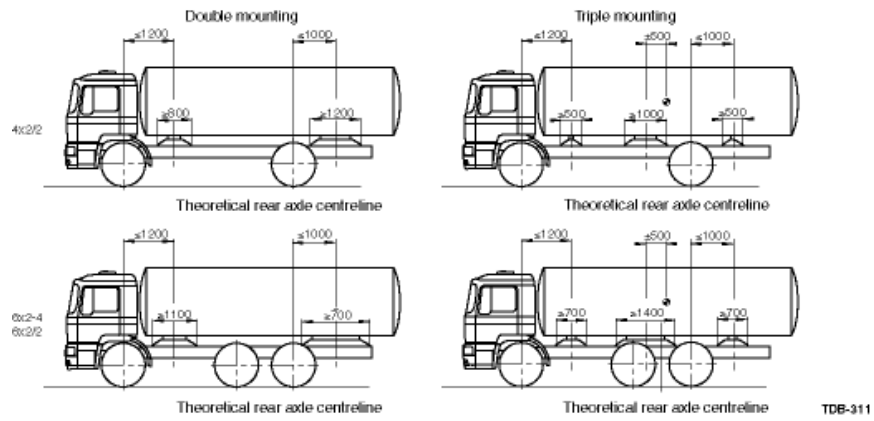

Figure - 32
Requirements for Tank Mountings for Designs without Sub-frames

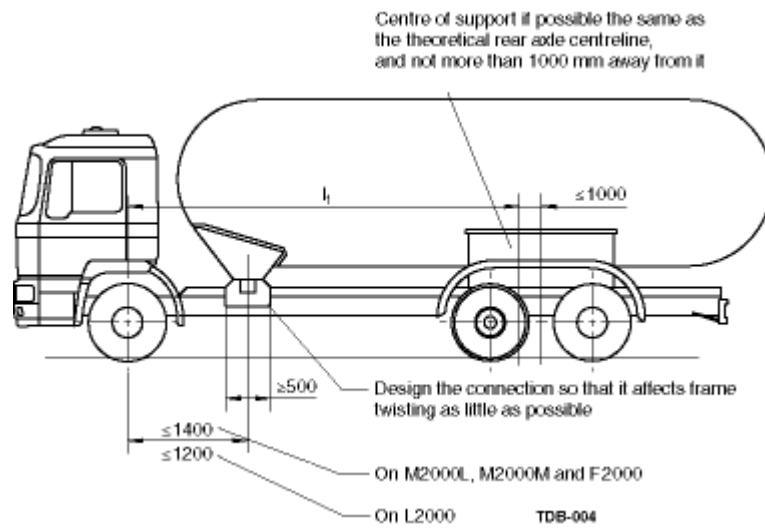

Figure-33
Continuous Sub-frame

Table 7
Chassis without Sub-frames for Tanker Bodies
with Double and Triple Mountings

Vehicle range	Model*	Wheel formula	Suspension	Wheelbases [mm]
M2000L	L74	4x2/2	leaf-leaf	3575... 4250
	L76		leaf-air	"
	L79		full air	"
	L81		leaf-leaf	"
	L84		leaf-air	"
	L86		full air	"
	L87		leaf-leaf	"
	L88		leaf-air	"
	L89		full air	"
M2000M	M38	4x2/2	leaf-leaf	"
	M39		leaf-air	"
	M40		full air	"
F2000	T31	4x2/2	leaf-leaf	3800... 4500
	T32		leaf-air	"
	T33		full air	"
	T36	6x2/2	leaf-air	4100... 4600 ...1350
	T37	6x2-4	full air	"

* For model allocation, see "General" booklet

Table 8
Size Designations of Freight Containers as per ISO 1669

Freight Container Designation	Nominal Length		Maximum Height			Maximum Width	
	m	ft.	mm	ft.	in.	mm	ft.
1AAA	12	40	2896	9	6	2438	8
1AA	12	40	2591	8	6	2438	8
1A	12	40	2438	8		2438	8
1AX	12	40	2438	8		2438	8
1BBB	9	30	2896	9	6	2438	8
1BB	9	30	2591	8	6	2438	8
1B	9	30	2438	8		2438	8
1BX	9	30	2438	8		2438	8
1CC	6	20	2591	8	6	2438	8
1C	6	20	2438	8		2438	8
1CX	6	20	2438	8		2438	8
1D	3	10	2438	8		2438	8
1DX	3	10	2438	8		2438	8

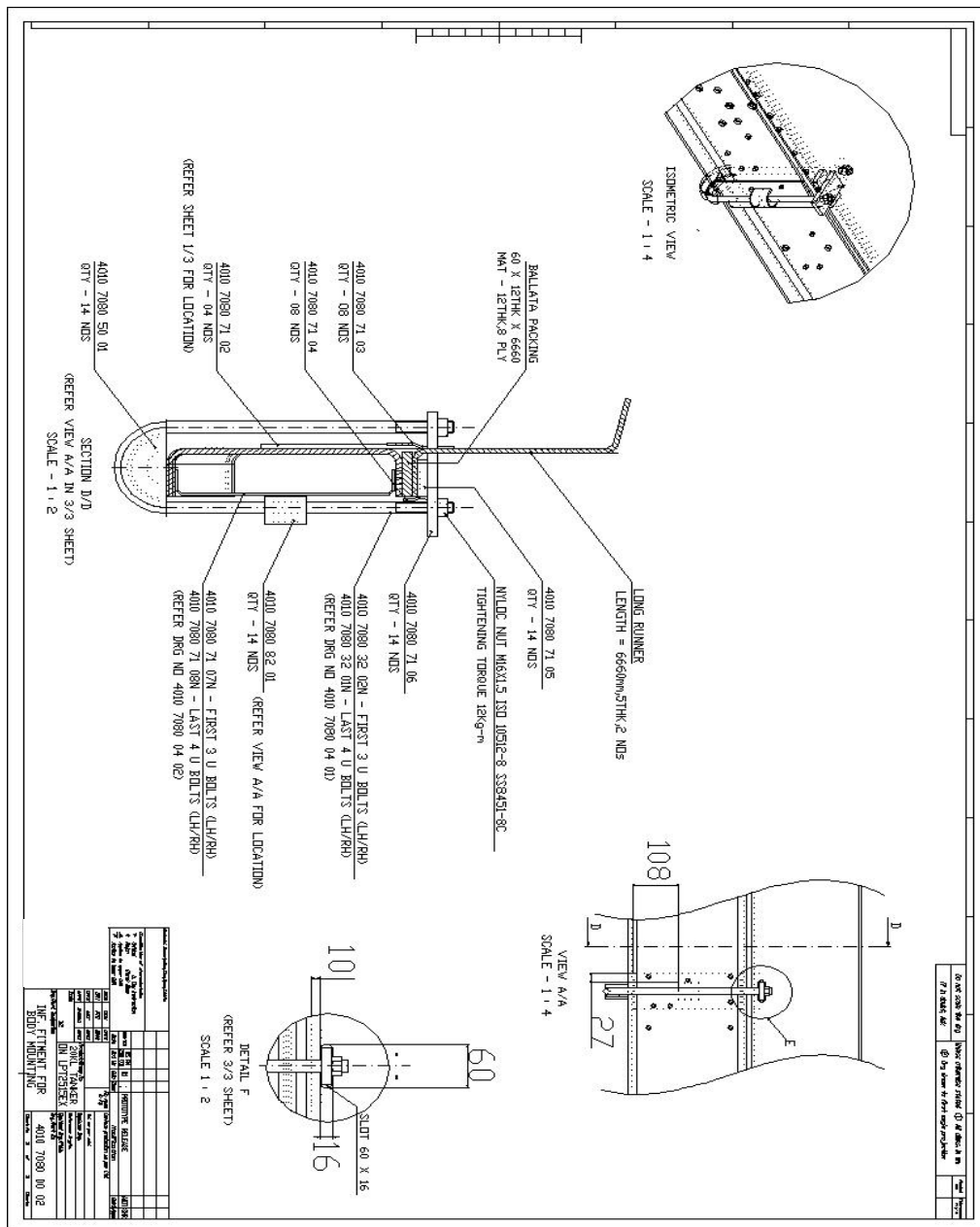

Figure-34
Details of Tanker Mounting

SECTION - 7.0**WORKING STABILITY OF VEHICLES MEANT FOR
CARRIAGE OF HAZARDOUS GOODS****LIST OF CONTENTS**

7.1	Terms and Definitions
7.2	Application for Approval
7.3	Approval
7.4	Approval Tests and Specifications.
7.5	Stability Criteria
7.6	Modification of the Vehicle Type and Extension of Approval
ANNEXURES	
Annexure - 1	Roll Over Stability / Tilt Table Test Procedure
Annexure - 2	Lateral Stability Calculation
Annexure - 3	Model Calculation Report

7.1 Terms and definitions

For reference in this chapter :

- 7.1.1 **"Approval of a vehicle"** means approval of a vehicle type with regard to rollover stability.
- 7.1.2 **"Vehicle type"** means a category of vehicle, which does not differ in such essential respects as:
- Vehicle category, (as per IS :14272) and type (truck, prime mover/tractor, full trailer, semi-trailer, centre-axle trailer etc)
 - Maximum mass
 - Cross-section profile of the tank (circular, elliptical, maxi-volume)
 - Maximum height of the centre of gravity of the unladen vehicle
 - Distribution of mass among the axles (including fifth wheel)
 - Number and arrangement of the axles (including axle spacing)
 - Suspension arrangements in relation to roll characteristics
 - Tyre size and structure (radial ply, diagonal ply or bias belted)
 - Track width
 - Wheel base
- 7.1.3 **"Laden vehicle"** except where otherwise stated, means a vehicle so laden as to attain its "maximum mass".
- 7.1.4 **"Maximum mass"** means the technically permissible maximum mass stated by the vehicle manufacturer.
- 7.1.5 **"The distribution of mass among the axles"** means the proportion of the maximum permissible mass borne by each axle, as declared by the vehicle manufacturer.
- 7.1.6 **"Suspension trim height"** means the distance between the wheel centre and a fixed point on the chassis as declared by the vehicle manufacturer.
- ## 7.2 Application for approval :
- The type approval application shall be accompanied by the following.
- 7.2.1 The application for approval of a vehicle type with regard to rollover stability shall be submitted by the vehicle manufacturer / body builder or his duly accredited representative.
- 7.2.2 A detailed description of the vehicle type with regard to the items specified Classes.
- 7.2.3 Photographs and/or diagrams and drawings of the vehicle showing the vehicle type in front, side, and rear elevation
- 7.2.4 Particulars of the vehicle's mass.

7.2.5 A vehicle, representative of the vehicle type to be approved, shall be submitted to the Technical Service conducting the approval tests.

7.3 Approval :

7.3.1 If the vehicle type submitted for approval pursuant to this Regulation meets the requirements of Paragraph 8.4 below, approval of that vehicle type shall be granted by the authorized test agencies.

7.4 Approval Test and Specifications :

7.4.1 The vehicle shall undergo a tilt table test in accordance with Annexure-1 to this section, which simulates a non-vibratory steady-state turn. As an alternative a calculation method in accordance with Annexure-2 to this section may be used to prove the stability. If there is any doubt or dispute a tilt table test shall be used.

7.4.2 The result of the tilt table test or the calculation method shall be considered satisfactory if the conditions set out in Paragraphs 8.5 below are satisfied.

7.5 Stability Criteria :

7.5.1 The criteria, using the corresponding Annexure-1 or Annexure-2, must fulfill one of the following conditions, subject to Paragraph 8.5.1.2.

7.5.1.1 Tilt table test: Tilt table test

The static rollover stability of the vehicle is considered to be passed, if overturning does not occur up to the tilt table angle of 23° for all tests in both (Left & Right) tilt directions. One consecutive retest is allowed if the vehicle fails in one of the three tests for a specific direction.

7.5.1.2 **Calculation method:** The rollover stability of the vehicle shall be such that the point at which overturning occurs would not be passed if a lateral acceleration of 4 m/s² has been reached.

7.5.1.3 **Particular requirements:** No contact between parts of the vehicle shall occur which are not intended to come into contact during normal use.

7.6 Modification of the Vehicle Type and Extension of Approval: Every modification which affects the vehicle type as defined in Paragraph 8.1 above (for instance the chassis, body, suspension, axle configuration, etc.) shall be notified to the approving agency which approved the vehicle type. The agency may then either:

- Consider that the modifications made are unlikely to have an appreciable adverse effect and that in any case the vehicle still complies with the requirements, or
- Require a further test report from the Technical Service responsible for conducting the tests.

Annexure - 1 of Section 7.0

ROLL OVER STABILITY / TILT TABLE TEST PROCEDURE

"Rollover threshold" means the instant when all the wheels on one side of the vehicle have lost contact with the tilt table surface.

A. General conditions:

A 1. The Tilt Table

A rigid surface should be used. The tyres may rest against a safety block or step during the test to prevent sideways slipping, provided that the safety block does not influence the test result.

A2. Wind Conditions

If the tilt table test rig is placed outside, the lateral wind velocity shall not exceed 3 m/s and the total wind velocity shall not exceed 5 m/s.

A3. Tyres

The tyres shall be inflated to pressures as specified by the vehicle manufacturer for the test vehicle at the laden condition. The tolerance for the inflation pressure in a cold state is $\pm 2\%$.

A4. Operating Components

A.4.1. All operating components likely to influence the results of this test (e.g. condition and setting of springs and other suspension components and suspension geometry) shall be as specified by the manufacturer.

A.4.2. Height-leveling systems should be deactivated (held at static values) during the actual tilt to avoid inflation/deflation of suspension during the tilt. Cross-coupling from side to side may need to be deactivated. An exception can be made for levelling systems with very short response time of less than one second.

B. Measuring accuracy :

The tilt table angle shall be measured with an accuracy of better than 0.3° .

C. Non power-driven vehicles :

C.1. If the vehicle is a centre-axle trailer, the vehicle may be tested with a power-driven vehicle. Any power-driven vehicle, substitute or support which has the appropriate coupling system and height may be used, as this will not influence the results.

- C.2. If the vehicle is a semi-trailer, the vehicle shall be tested with a tractor or a substitute. The tractor/substitute will influence the results and therefore a [reference tractor/substitute] shall be used.

D. Vehicle loading condition :

The standard test condition is the maximum loaded condition; the laden vehicle. In this maximum loading condition, the tank vehicle shall be fully loaded, without exceeding the maximum authorised mass and maximum authorised axle loads.

If the normal load to be carried by the tank vehicle is classified as being of a dangerous type, it may be replaced by water or another non-dangerous test load. If the standard test conditions,

(a) fully laden or (b) maximum mass, cannot be fulfilled with this test load then:

(a) a filling factor of the tank between 100% and 70% is acceptable. If at the minimum filling factor of 70% the total mass and/or axle loads still exceed the maximum authorised mass and maximum authorised axle loads, a test load with a lower density shall be used. The distribution of mass of the tank (including the test load) among the axles shall be proportional to the maximum loaded condition. Tanks provided with compartments shall be differentially loaded so that the centre of gravity height at each axle or axle group is as close as possible to the real centre of gravity height.

(b) a calculation shall be issued by the vehicle manufacturer (1) to provide a new required maximum tilt table angle for the lighter test load.

E. Safety

Restraints shall be used to prevent final rollover but these shall be arranged so as not to interfere with the test.

F. Test procedure :

The vehicle shall be aligned with all units in a straight line parallel to the tilt table axis such that no axle longitudinal centre line is off line by more than 25 mm. The vehicle shall be fixed in the longitudinal direction to prevent forward and rearward movement, provided that the method of fixing does not influence the test result. All steerable axles of the

Vehicle shall be locked to prevent axle lateral movement and/or turning of the wheels in a steering direction. The vehicle shall be tilted at very low rates of 0.25 °/s or less. This procedure consists of a very gradual increase in the tilt table angle up to the required maximum angle or the rollover threshold. The vehicle shall be gradually tilted three times each to the right and left of the vehicle longitudinal centre line. Due to the influences of stick-slip in the vehicle's suspension

systems and coupling components, the vehicle shall be removed from the table between the tests and driven around to "randomise" and "equalise" the influences of stick-slip and hysteresis.

Annexure - 2 of Section 7.0

LATERAL STABILITY CALCULATION**A. General:**

The lateral stability of tank vehicles is calculated by simulation of a steady state circular test (constant radius, constant speed and consequently constant lateral acceleration). The calculation method take into account the main factors which influence the stability, such as the height of the centre of gravity, the track width and all factors which result in a lateral shift of the centre of gravity (axle roll stiffness, suspension roll stiffness, etc.). In case of semi-trailers the tractor will be simulated with a reference kingpin roll stiffness.

The specifications of the calculation method are:

1. axle roll centre is at ground level;
2. vehicle structure is assumed to be rigid;
3. vehicle is symmetrical about its center line;
4. tyre and suspension deflections are linear;
5. lateral deflection of suspensions is zero.

B. Definitions:

For the purposes of this calculation:

"Bogie" means an axle group with compensatory load distribution, in which zero load is attained on all wheels on a given side simultaneously.

C. Symbols (See also Figure 1 below) :

i (-)	=	Axle/bogie index ($i = 1 - n$, front to - axle/bogie;
i	=	T , all axles/bogies;
i	=	M , stiffest axle/bogie; and for semi-trailers only $i = K$, kingpin)
m_i	=	Nominal suspension roll axis height
A_i (kN)	=	Axle/bogie load
C_{DGi} (kNm/rad)	=	Suspension roll stiffness at axle roll axis
C_{DGMi} (kNm/rad)	=	Equivalent suspension roll stiffness at ground level C
D_{Ri} (kNm/rad)	=	Axle/bogie roll stiffness
C_{DRESi} (kNm/rad)	=	Resolved combined suspension roll stiffness at ground level
F_{RVi} (kN/m)	=	Vertical tyre rate for each axle/bogie (inclusive the double effect of twin tyres)
U_i (kN)	=	Unsprung weight
T_{Ni} (m)	=	Nominal track width

D. General conditions :

Height-leveling systems are not taken into account (held at static values).

E. Trailers :

E1. If the trailer is a full trailer or a central axle trailer the calculation does not have to include the coupling with the towing vehicle.

E2. If the trailer is a semi-trailer, the tractor will be simulated with a reference kingpin roll stiffness, which represents the tractor suspension, tyres, chassis & fifth wheel flexibility at ground level.

F. Vehicle loading condition :

The test condition is the maximum loaded condition; laden vehicle. In this maximum loading condition, the tank vehicle shall be fully loaded, without exceeding the maximum authorized mass and maximum authorized wheel loads.

G. Calculation method :

G1. Calculation of the combined roll stiffness and the pseudo vehicle roll angle at wheel lift of each axle/bogie with the formulae:

G1.1 Axles/bogie with single tyres:

axle/bogie roll stiffness:

$$C_{DRi} = \frac{F_{Rvi} * T^2 N_i}{2}$$

equivalent suspension roll stiffness ground level :

$$C_{DGMi} = C_{DGi} * \left(\frac{H_N}{H_N - m} \right)^2$$

combined roll stiffness to simulate lateral CG shift :

$$C_{DRESi} = \frac{C_{DGMi} * C_{DRi}}{C_{DGMi} + C_{DRi}}$$

pseudo vehicle roll angle at wheel lift

$$\theta_i = \frac{A_i * T N_i}{2 * C_{DRESi}}$$

G1.2. Axles/bogie with twin tyres:

Theoretical track width for twin tyres :

$$T_i = \sqrt{T^2 N_i + MA^2}$$

axle/bogie roll stiffness :

$$C_{DRi} = \frac{F_{RVi} * T_i^2}{2}$$

equivalent suspension roll stiffness ground level

$$C_{DGMi} = C_{DGi} * \left(\frac{H_N}{H_N - m} \right)^2$$

combined roll stiffness to simulate lateral CG shift

$$C_{DRESi} = \frac{C_{DGMi} * C_{DRi}}{C_{DGMi} + C_{DRi}}$$

vehicle pseudo roll angle at wheel lift

- G2** In case of semi-trailers, calculation of the kingpin effects with the following formulae:

track width $T_k = \frac{\sum_{i=1}^2 T_i}{n}$

roll stiffness $C_{DRESK} = A_k * 4$

- G3** After the resolved combined stiffness and pseudo roll angle for each axle/bogie are calculated the totals for the complete vehicle are determined:

total vehicle weight ⁽¹⁾ $A_T = \sum_{i=1}^n A_i + A_k$

total unsprung weight $U_T = \sum_{i=1}^n U_i$

effective track width ⁽¹⁾ $T_T = \frac{\sum_{i=1}^n (T_i * A_i)}{A_T} + \frac{T_k * A_k}{A_T}$

total roll stiffness ⁽¹⁾ $C_{DREST} = \sum_{i=1}^n C_{DRESi} + C_{DRESK}$

G4. Select the axle/bogie with the lowest value of θ , for this indicates that first wheel lift will occur. To distinguish this axle/bogie from the other axles/bogies, allocate the following:

A_M = Axle load of axle/bogie with lowest θ .

U_M = Unsprung weight of axle/bogie with lowest θ .

T_M = Track width of axle/bogie with lowest θ .

C_{DRESM} = Roll stiffness axle of axle/bogie with lowest θ .

G5. Lateral Stability Calculation

G5.1 The effective mass factor of the stiffest axle/bogie FE

$$F_E = \frac{C_{DRESM}}{C_{DREST}}$$

G5.2 The lateral acceleration at first wheel lift q_M :

$$q_M = \frac{A_M * T_M}{2 * \left((F_E * A_T * H_G) + \frac{(A_T - U_T) * F_E * H_N^2}{C_{DRESM} - (A_T * F_E * H_N)} \right)}$$

G5.3 The maximum optimal theoretical lateral acceleration at overturn q_T :

$$q_T = \frac{A_T * T_T}{2 * \left((A_T * H_G) + \frac{((A_T - U_T) * H_N)^2}{C_{DREST} - (A_T * H_N)} \right)}$$

G5.4 Linear interpolation between the lateral acceleration at first wheel lift and the Maximum theoretical lateral acceleration gives the correlated lateral acceleration at overturn q_C :

$$q_C = q_T - (q_T - q_M) * \frac{A_M}{A_T}$$

Annexure 3 of Section 7.0

MODEL CALCULATION REPORT

Calculation Report

1.	Trade name or mark of the vehicle
2.	Vehicle type
3.	Manufacturer
4.	Height of the centre of gravity of the spring mass
5.	Unsprung weight of all axles
6.	Nominal suspension roll axis height of all axles
7.	Suspension roll stiffness of all axles
8.	Vertical tyre rate (inclusive double effect of twin tyres)
9.	In case of twin tyres, the twin tyre width
10.	Calculation results, $q_c =$
11.	Technical service which carried out the calculation
12.	Date
13.	Signature

SECTION - 8.0

TYPE APPROVAL AND COP PROCEDURE

8.1 SCOPE:

8.1.1 The Type Approval Procedure specified in this code is applicable to truck Cab body including dangerous goods carriers with GVW greater than 3.5 tonnes

8.1.2 The requirements of this code also apply to vehicles of N2, N3, categories.

The requirements of this section as well as the Code would only apply to organizations who construct cabs / bodies on chassis supplied by vehicle manufacturers. It will not apply to the vehicle / chassis manufacturers who are currently under the type approval and CMVR certification system within the scope of this procedure.

8.1.3 The system for approval of Prototype (Rule 126) and Conformity to Production (Rule 126A) to comply with provisions with respect to the safety, strength and technical requirements specified in this “Code of Practice for Construction and approval for Truck Cab and Truck Bodies.”

8.2 Procedure for Type Approval :

8.2.1 Design of Truck Cab and Body Building and other Aggregates / Units :

8.2.1.1 Truck Cab and Body Builders (TCBB) may follow their own design complying with the provisions of this Code. They shall follow the designs / recommendations of the vehicle / chassis manufacturers, wherever necessary and applicable.

8.2.2 Prototype Type Approval of Vehicle and other Aggregates / Units :

8.2.2.1 TCBB shall submit application for Type Approval of prototype built as per 8.2.1.1 above.

8.3 Application for Type Approval :

8.3.1 The application for type approval of the vehicle type shall be submitted to the Test Agency by the TCBB with a description of the Vehicle type(s) accompanied by the following documents, as applicable to the provisions for which such compliance is sought:

- a) List of provisions for which compliance is sought to be established.
- b) The Truck body builder shall submit all the relevant information as given in Annexure - I.
- c) The Truck Body Builder shall submit additional information on Trucks meant for carrying dangerous and hazardous goods as given in Annexure – II.
- d) Copies of certificates or test reports of compliance to various provisions, which may have already been obtained from other recognized Testing Agencies.
- e) Copies of test reports for other models/variants, if any, which can be used for establishing compliance of the model to be type approved, with a note explaining the details.
- f) Copy of certificate of incorporation of the organization, if not already submitted.
- g) Publications available.

8.4 Type Approval of Safety Components / Sub-assemblies :

- 8.4.1 In addition to the safety components notified under Rule 124 of Central Motor Vehicle Rules, 1989 the Type Approval of, door components like locks and hinges, wheel rims etc., and any other components notified from time to time shall be obtained separately and copies of such certificates / reports shall be furnished in addition to the requirements stipulated in 8.3.1 above.

8.5 Methods of Establishing Compliance

- 8.5.1 Depending upon the provision, the compliance can be established by either comparison of the values declared in the Technical Specifications with those in the provisions of Central Motor Vehicle Rules, 1989, or checking the fitment of part(s) on the vehicle or by testing, as applicable. Applicability of rules, method of establishing the compliance and details of the test procedures shall be as specified in this code.

8.6 Certificate of Compliance for Type Approval :

- 8.6.1 After compliance is established for all the provisions, applicable to that model/variant(s), a Certificate of Compliance consolidating all applicable provisions shall be issued by the Testing Agency. The Technical Specifications as declared by the manufacturer shall be counter signed by the Testing Agency and shall be attached to the certificate of compliance.

8.7 Conformity of Production (CoP) :

- 8.7.1 CoP shall be carried out at least once in 12 months by any of the testing agencies notified under Rule 126 of Central Motor Vehicle Rules, 1989, or any other agency authorized by the Government. A minimum of one unit shall be subjected to COP.

8.8 Non-Conformity of Production :

- 8.8.1 The accreditation granted to the truck cab and body building unit manufacturing unit may be suspended or withdrawn in case of non conformity. The unit may be re-evaluated as per directives of the Government.

SECTION - 9.0

ACCREDITATION SYSTEM FOR TRUCK CAB AND BODY BUILDERS (TCBB)

Truck Cab and Body Building manufacturing is being carried out by a large number of small and medium scale organizations spread throughout the country. Truck Cab and Body Builder (TCBB) organizations construct the bodies on chassis procured from vehicle / chassis manufacturers. Presently, only the vehicle / chassis manufactured by vehicle manufacturers undergo a formal type approval and certification procedure as per the various provisions of CMVR.

The Committee feels that there is a need to set up a formal institutional mechanism to monitor the manufacturing and process conformity and compliance of CMVR provisions of the above said TCBB units. For example, in respect of items like petroleum tankers and certain other hazardous goods carriers, there is an established control procedure administered by the Chief Controller of Explosives. The Committee recommends that a procedure on the above lines is instituted in respect of truck and body building

The Committee also recommends creation of a cadre of technical personnel to effectively implement the procedure in order to ensure that all truck cabs / bodies comply with all the relevant provisions of the CMVR as well as the Code of Practice for Truck Body formulated in this document.

The Ministry of Road Transport and Highways (MoRT&H), is presently evolving a system for the Accreditation of the Bus Body Builders in the country. The Committee also recommends that the same system be extended for the truck body building as well. MoRT&H may separately notify the administrative mechanism for the Accreditation of Truck Body Builders.

	Annexure – I	
	(See 8.3.1(b))	
	(To be submitted by the Vehicle Manufacturer / Body Builder to the Test Agency)	
	TECHNICAL INFORMATION ON TRUCK CAB, LOAD BODY & RELATED TECHNICAL FEATURES	
1.0	Details of Vehicle Manufacturer	
1.1	Name & address of the vehicle manufacturer	
1.2	Telephone No.	
1.3	Fax. No.	
1.4	E-mail address	
1.5	Contact person	
1.6	Plant(s) of manufacture	
2.0	Details of Truck Body / Tanker Builder	
2.1	Name & address of the body builder	
2.2	Telephone No.	
2.3	Fax. No.	
2.4	E-mail address	
2.5	Contact person	
3.0	Name of model and variants (if any)	
3.1	CMVR certificate reference(s)	
3.2	Type and General commercial description (s)	
4.0	Vehicle type	
4.1	Type of vehicle (rigid / articulated / combination)	
4.2	Usage (goods / passenger / tractor / / others)	
4.3	Control (forward / semi-forward / normal / others)	
4.4	Drive (4x2 / 4x4 / 6x4 / others)	
4.5	Cab type (fully built cab/sleeper cab/cowl/front end structure/with wind shield/without wind shield)	
4.6	Load body, type and drawing	
5.0	Category of vehicle	
5.1	As per AIS-053 as amended from time to time	

6.0	Vehicle Details	
6.1	Chassis types approved for body installation	
6.2	Type of Control (normal control / full forward control etc.	
6.3	Number of axles and wheels	
6.4	Chassis (overall drawing)	
6.5	Frame type	
6.6	Cross section and view drawing	
6.7	Dimensions mm: length and width	
6.8	Position and arrangement of engine	
7.0	Vehicle Dimensions (Specify drawing reference)	
7.1	Length mm	
7.2	Width mm	
7.3	Height (Unladen) mm	
7.4	Wheel base mm	
7.5	Minimum axle spacing, mm (for articulated/combination vehicles)	
7.6	Wheel track mm	
7.6.1	Front	
7.6.2	Rear	
7.6.3	Other axles (for articulated/combination vehicles)	
7.7	Body overhang mm	
7.7.1	Front end	
7.7.2	Rear end	
7.8	Frame overhang mm(in case of vehicles without complete body)	
7.8.1	Front end	
7.8.2	Rear end	
7.9	Inner dimensions of room or platform (For goods carriage vehicles only)	
7.9.1	Length	
7.9.2	Width	
7.9.3	Height	
7.10	Lateral projection	
8.0	Weights	
8.1	Vehicle kerb weight kg	
8.1.2	Front axle	
8.1.3	Rear axle	
8.1.5	Total	
8.2	Gross vehicle weight kg	

8.3	Maximum permissible axle weights kg	
8.3.1	Front axle	
8.3.2	Rear axle	
8.4	Gross combination weight	
8.4.1	Front axle	
8.4.2	Rear axle	
9.0	Body	
9.1	Type of Truck / Tanker	
9.2	Comfort Category	
9.3	Dimension drawing and photograph of the vehicle with representative body	
9.4	Range of vehicle dimension (overall)	
9.5	Dimensional drawings of the body depicting chassis connecting members	
9.6	Material used for construction	
9.7	Material used for Cab	
9.8	Structure Material (as per ISO : 3795)	
9.9	Size of sections (A Table with details of cross sectional dimensions of the sections be enclosed)	
9.10	Material used for cab other than Structural (ISO :3795)	
9.11	Method of construction	
9.12	(Brief construction method)	
9.13	Area for Cab (m ²)	
9.14	Number of Seats	
9.14.1	Driver Seat	
9.14.2	Co-Driver Seat	
9.15	Number of sleeper berths, layout with dimensions (As per Seat Layout)	
9.16	Number of Service doors, layout with dimensions	
9.17	Number of emergency exit, layout with dimensions	
9.18	Number of escape hatches, layout with dimensions	
9.19	Area of luggage Transportation on roof (m ²), layout with dimensions	
10.0	Clearance	
10.1	Minimum ground clearance	
10.2	Approach angle	
10.3	Departure angle	
10.4	Ramp-over angle	
11.0	Seating capacity	

11.1	Maximum (including driver) for completely built vehicles	
11.2	Sketch showing layout of seats with appropriate dimensions of seats & their location on the vehicle platform	
12.0	Maximum Stable inclination	
12.1	Left	
12.2	Right	
13.0	Body Panels	
13.1	Outer Panels	
13.1.1	Material	
13.1.2	Thickness	
13.2	Inner Panels	
13.2.1	Material	
13.2.2	Thickness	
13.3	Roof Panels (If closed type load carrier)	
13.3.1	Material	
13.3.2	Thickness	
13.4	Floor Panels	
13.4.1	Material	
13.4.2	Thickness	
13.5	Type of anti-slip coating	
14.0	Step well Guard	
14.1	Height from the floor	
14.2	Projection from the side wall	
15.0	Cab Luggage Rack	
15.1	Width from sidewall	
15.2	Height from Roof	
16.0	Driver Partition	
16.1	Dimension of partition with respect to rear edge of driver seat	
	(Rear most position of driver seat)	
17.0	Driver's Work Area (Refer Figure-2 of Section -2) A separate figure or drawing be attached	
17.1	Overall length of the cab, mm	
17.2	Height of floor from 2nd foot step top, mm	
17.3	Distance from floor to the driver's seat top, mm	
17.4	Distance from the floor to the bottom of the steering wheel, mm	
17.5	Distance from the roof to the floor, mm	
17.6	Height of the cab from ground, mm	
17.7	Thickness of the berth, mm	

17.8	Roof to upper berth gap, mm (Min)	
17.9	Lower berth top to upper berth bottom , mm (Min)	
17.10	Berth width, mm	
17.11	Lower berth height from the floor at rear, mm	
17.12	Height of cab at rear, mm	
17.13	Seat to steering wheel gap, mm	
17.14	Width of the door , mm (Min)	
17.15	Height of door, mm (Min)	
17.16	Width of window, mm (Min)	
17.17	Height of window, mm (Min)	
17.18	Width of observation window (on door) at top, mm	
17.19	Width of observation window (on door) at bottom, mm	
17.20	Height of observation glass, mm	
17.21	Minimum length of the sleeper berth measured from the longitudinal axis of the berth (left to right), mm	
17.22	Minimum distance from H point to roof measured along the back rest at 12 degree angle, mm (head room)	
17.23	Thigh clearance for the driver-The vertical distance measured from top of the seat cushion of the driver's seat the bottom of the steering Wheel, mm	
17.24	Heel point –Minimum distance from the inner face of the bulk head, mm	
17.25	Adjustment range for the thigh clearance, mm	
18.0	Hand hold / Climb facility (Refer Figure –3 of Section –2) A separate figure or drawing shall be attached.	
18.1	Maximum height from ground to surface of first step, mm	
18.2	Maximum vertical distance between top surface of subsequent steps, mm	
18.3	Minimum step depth, mm	
18.4	Minimum step clearance including step depth, mm	
18.5	Minimum step width (other than first step) , mm	
18.6	Minimum step width for lower step, mm	
18.7	Reference point specified by chassis manufacturer (SGRP) , mm	
18.8	Cross section of handle, mm	
18.9	Width of grab handle on "B pillar", mm	
18.10	Width of grab handle on "A pillar", mm	

18.11	First hand hold/ hand rail height from ground level (max) , mm	
18.12	Maximum height of the grab handle at Rear-"Hold-U" from bottom of rear floor (B pillar side) , mm	
18.13	Maximum height of the grab handle to floor bottom at front (for hand "Hold-V") (A pillar side) , mm	
18.14	Minimum thickness of the foot step, mm	
18.15	Minimum height of the upper most step to floor, mm	
18.16	Compliance to AIS-046 established (Yes / No)	
19.0	External Projections	
19.1	Ornaments	
19.2	Projection for headlight	
19.3	Radiator grills (Applicable of on external surface)	
19.4	Gap between individual elements	
19.5	Radius of curvature of individual element	
19.6	Body Panel (In case of radius of curvature of folds in body panels are less than 2.5mm	
19.7	The scaled drawing of folds contour and H value as per Annex A of SS29/IS 13942 is required (to be submitted)	
19.8	Radius of curvature of lateral Rain/Air deflector	
19.9	Hinges	
19.10	Handles	
20.0	Rear Under run Protective device (RUPD)	
20.1	Height of lower edge of the device from the ground (mm)	
20.2	Width of the device (mm)	
20.3	Drawing of the rear under-run protective device with dimensions.	
20.4	Material (Metal/Fibre/etc.)	
21.0	Lateral Protection (Side Guards)	
21.1	Height of the lower edge of the Side Guard.	
21.2	Drawing of the lateral protection device fitted on the vehicle with dimensions	
21.3	Material (Metal/Fiber/etc.)	
22.0	Driver / Co-driver door	
22.1	Make & identification	
22.2	Name of the producer	
22.3	Position of controls	
22.4	Control Circuit (schematic diagram)	
23.0	Door locks and hinges	
23.1	Doors	

23.1.1	No. of doors	
23.1.2	Position and type of door	
23.2	Door lock	
23.2.1	Name of manufacturer	
23.2.2	Identification mark	
23.3	Door hinge	
23.3.1	Name of manufacturer	
23.3.2	Identification mark	
24.0	Hood latch	
24.1	Name of manufacturer	
24.2	Type	
24.3	Identification mark	
25.0	Windows on driver / co-driver door	
25.1	Winding type provided (Yes/No)	
26.0	Windows other than door windows	
26.1	Type and description	
26.2	Drawing with dimensions	
27.0	Safety glass	
27.1	Front windshield (laminated)	
27.1.1	Make and identification	
27.1.2	Type (flat/curved, clear/tinted)	
27.1.3	Thickness mm	
27.1.4	No. of pieces	
27.1.5	Radius of curvature (If curved)	
27.2	Side Windows	
27.2.1	Make and identification	
27.2.2	Type (flat/curved, clear/tinted, toughened)	
27.2.3	Thickness mm	
27.2.4	Radius of curvature (If curved)	
27.3	Rear Window	
27.3.1	Make and identification	
27.3.2	Type (flat/curved, clear/tinted, toughened)	
27.3.3	Thickness mm	
27.3.4	Radius of curvature (If curved)	
28.0	Rear view mirror	
28.1	Left	
28.1.1	Name of producer	
28.1.2	Type	
28.1.3	Class of mirror	

28.1.4	Manufacturer's ID number	
28.1.5	Trade name or mark location	
28.1.6	Dimension & radius of curvature	
28.2	Right	
28.2.1	Name of producer	
28.2.2	Type	
28.2.3	Class of mirror	
28.2.4	Manufacturer's ID number	
28.2.5	Trade name or mark location	
28.2.6	Dimension & radius of curvature	
28.3	Inside	
28.3.1	Name of producer	
28.3.2	Type	
28.3.3	Class of mirror	
28.3.4	Manufacturer's ID number	
28.3.5	Trade name or mark location	
28.3.6	Dimension & radius of curvature	
28.4	Sketch showing mounting arrangement of mirrors	
29.0	Wind Screen Wiper	
29.1	Type	
29.2	No. of wipers	
29.3	Wiper motor	
29.3.1	Name of manufacturer	
29.3.2	Type and identification	
29.3.3	Rated voltage	
29.3.4	Frequency of wiping	
29.4	Wiper arm	
29.4.1	Length	
29.4.2	Manufacturer and Identification	
29.5	Wiper blade	
29.5.1	Length	
29.5.2	Manufacturer and Identification	
29.5.3	Rubber material	
29.5.4	Type of fixing (as per IS:7827)	
29.6	Drawing indicating the seat back angle, seat travel, H point, Rake angle ,F dimension And steering wheel position (Ref document ARAI005CMVR101(2) December 1992)	

30.0	Wind Screen Washer	
30.1	Name of producer	
30.2	Type	
30.3	Number of nozzles	
30.4	Spray Area	
31.0	Equipment for occupant's safety	
31.1	Driver Seat belt	
31.1.1	Name of producer	
31.1.2	Identification Type	
31.1.3	Number	
31.2	Head restraint	
31.2.1	Name of producer	
31.2.2	Type	
31.3	Passenger Seat	
31.3.1	Name of producer	
31.3.2	Type	
31.3.3	Frame structure Material	
31.3.4	Section size	
31.3.5	Pad material	
31.3.6	Upholstery	
32.0	Super Structure (Load body)	
32.1	Type and description	
32.2	Floor Height from the ground (unladen)	
32.3	Slope of floor	
32.4	Material used for Floor construction	
32.5	No. of Cross sections used	
32.6	(If more than two tabulate in a table)	
32.7	Details of the Load Body Carrier	
32.8	Maximum Height	
32.9	Maximum Width	
32.10	Maximum Length	
33.0	Bumper	
33.1	Size	
33.1.1	Front	
33.1.2	Rear	
33.2	External Projection	
33.3	Clearance between bumper & body	

34.0	Spray Suppression System	
34.1	Make, Country of origin (If imported)	
34.2	Type (Water separator / Pulveriser)	
34.3	Identification No. / Part No.	
34.4	Size	
34.5	Drawing / Photographs showing the mounting details with dimensions	
35.0	Fuel filler	
35.1	Aperture	
35.2	Position	
36.0	Fire Extinguisher	
36.1	Number	
36.2	Type	
36.3	Capacity	
36.4	Name of Producer	
37.0	First Aid Equipment	
37.1	Number	
37.2	Contents	
38.0	Towing devices	
38.1	Type	
38.2	Name of manufacturer	
38.3	Capacity	
39.0	Horn :	
39.1	Make and Country of origin (if imported)	
39.2	Type (As per IS 1884 – 1993)	
39.3	Operating voltage	
39.4	Identification No. / Part No.	
39.5	Number	
39.6	Sketch showing mounting of horn	
39.7	The shape and material of the body work at the front of the horn, which might affect the level of the sound, emitted by the horn and have a masking effect	
39.8	Maximum vehicle speed for continuous operation, km/h.	
40.0	Lighting Installation requirements :	
40.1	External shape of the vehicle	
40.2	Head lamp leveling system	
40.3	Initial inclination	
40.4	Tell-Tale	
40.5	Description and sketch showing the detail positions of Tell-Tale and seating layout (for M category vehicles)	

41.0	Head lamp :	
41.1	Main beam	
41.1.1	Make and Country of origin (if imported)	
41.1.2	Type of lens (Glass / Plastic)	
41.1.3	Identification No. / Part No.	
41.1.4	Number and Colour of Lens	
41.2	Dipped beam	
41.2.1	Make and Country of origin (if imported)	
41.2.2	Type of lens (Glass / Plastic)	
41.2.3	Identification No. / Part No.	
41.2.4	Number and Colour of Lens	
42.0	Front Fog Lamp :	
42.1	Make and Country of origin (if imported)	
42.2	Type of lens (Glass / Plastic)	
42.3	Identification No. / Part No.	
42.4	Number and Colour of Lens	
43.0	Rear Fog Lamp :	
43.1	Make and Country of origin (if imported)	
43.2	Type of lens (Glass / Plastic)	
43.3	Identification No. / Part No.	
43.4	Number and Colour of Lens	
44.0	Side Marker lamps :	
44.1	Make and Country of origin (if imported)	
44.2	Type of lens (Glass / Plastic)	
44.3	Identification No. / Part No.	
44.4	Number and colour of Lens	
45.0	Registration Plate lamp :	
45.1	Make and Country of origin (if imported)	
45.2	Type of lens (Glass / Plastic)	
45.3	Identification No. / Part No.	
45.4	Number and colour of Lens	
46.0	Position lamp / Parking Lamp - Front	
46.1	Front Position Lamp	
46.1.1	Make and Country of origin (if imported)	
46.1.2	Type of lens (Glass / Plastic)	
46.1.3	Identification No. / Part No.	
46.1.4	Number and colour of Lens	
46.2	Front Parking Lamp	
46.2.1	Make and Country of origin (if imported)	

46.2.2	Type of lens (Glass / Plastic)	
46.2.3	Identification No. / Part No.	
46.2.4	Number and colour of Lens	
47.0	Position lamp / Parking Lamp - Rear	
47.1	Rear Position Lamp	
47.1.1	Make and Country of origin (if imported)	
47.1.2	Type of lens (Glass / Plastic)	
47.1.3	Identification No. / Part No.	
47.1.4	Number and colour of Lens	
47.2	Rear Parking Lamp	
47.2.1	Make and Country of origin (if imported)	
47.2.2	Type of lens (Glass / Plastic)	
47.2.3	Identification No. / Part No.	
47.2.4	Number and colour of Lens	
48.0	Stop lamp (S1 / S2)	
48.1	Make and Country of origin (if imported)	
48.2	Type of lens (Glass / Plastic)	
48.3	Identification No. / Part No.	
48.4	Number and colour of Lens	
49.0	Reversing lamp :	
49.1	Make and Country of origin (if imported)	
49.2	Type of lens (Glass / Plastic)	
49.3	Identification No. / Part No.	
49.4	Number and colour of Lens	
50.0	Direction indicator Lamp :	
50.1	Front	
50.1.1	Make and Country of origin (if imported)	
50.1.2	Type of lens (Glass / Plastic)	
50.1.3	Identification No. / Part No.	
50.1.4	Number and colour of Lens	
50.2	Rear	
50.2.1	Make and Country of origin (if imported)	
50.2.2	Type of lens (Glass / Plastic)	
50.2.3	Identification No. / Part No.	
50.2.4	Number and colour of Lens	
50.3	Side	
50.3.1	Make and Country of origin (if imported)	
50.3.2	Type of lens (Glass / Plastic)	

50.3.3	Identification No. / Part No.	
50.3.4	Number and colour of Lens	
50.4	Type of flasher	
51.0	Hazard warning signal :	
51.1	Front	
51.1.1	Make and Country of origin (if imported)	
51.1.2	Type of lens (Glass / Plastic)	
51.1.3	Identification No. / Part No.	
51.1.4	Number and colour of Lens	
51.2	Rear	
51.2.1	Make and Country of origin (if imported)	
51.2.2	Type of lens (Glass / Plastic)	
51.2.3	Identification No. / Part No.	
51.2.4	Number and colour of Lens	
51.3	Side	
51.3.1	Make and Country of origin (if imported)	
51.3.2	Type of lens (Glass / Plastic)	
51.3.3	Identification No. / Part No.	
51.3.4	Number and colour of Lens	
52.0	Reflector :	
52.1	Front	
52.1.1	Make and Country of origin (if imported)	
52.1.2	Type	
52.1.3	Identification No. / Part No.	
52.1.4	Number and colour of Lens	
52.1.5	Area	
52.1.6	Shape	
52.2	Rear	
52.2.1	Make and Country of origin (if imported)	
52.2.2	Type	
52.2.3	Identification No. / Part No.	
52.2.4	Number and colour of Lens	
52.2.5	Area	
52.2.6	Shape	
52.3	Side	
52.3.1	Make and Country of origin (if imported)	
52.3.2	Type	
52.3.3	Identification No. / Part No.	
52.3.4	Number and colour of Lens	

52.3.5	Area	
52.3.6	Shape	
53.0	End – outline marker lamp (Top light)	
53.1	Front	
53.1.1	Make and Country of origin (if imported)	
53.1.2	Type of lens (Glass / Plastic)	
53.1.3	Identification No. / Part No.	
53.1.4	Number and colour of Lens	
53.2	Rear	
53.2.1	Make and Country of origin (if imported)	
53.2.2	Type of lens (Glass / Plastic)	
53.2.3	Identification No. / Part No.	
53.2.4	Number and colour of Lens	
53.3	Diagram of vehicle indicating location, reference axis, mark of apparent surface, contour of vehicle parts limiting geometric visibility of all lights and light signaling devices, location of extreme outer edges and longitudinal median plane of vehicle including following dimensions in mm.	
53.4	Along width of vehicle-horizontal distance between inner illuminating surfaces, distance between inner illuminating surfaces and outer most part of vehicle and distance between nearest point of illuminating surfaces of indicators and dipped-beam head lamp	
53.5	Along length of vehicle (where applicable)- distance between the transverse plane corresponding to the longitudinal rearmost extremity to center of reference of rear indicators	
53.6	Heights of highest and lowest point of illuminating surfaces	
54.0	Automotive bulbs :	
54.1	Head lamp bulb (main and dip)	
54.1.1	Make and Country of origin (if imported)	
54.1.2	Designation as per AIS-034	
54.2	Parking Lamp bulb – Front	
54.2.1	Make and Country of origin (if imported)	
54.2.2	Designation as per AIS-034	
54.3	Parking Lamp bulb - Rear	
54.3.1	Make and Country of origin (if imported)	
54.3.2	Designation as per AIS-034	
54.4	Direction indicator lamp bulb - front	
54.4.1	Make and Country of origin (if imported)	
54.4.2	Designation as per AIS-034	

54.5	Direction indicator lamp bulb - rear	
54.5.1	Make and Country of origin (if imported)	
54.5.2	Designation as per AIS-034	
54.6	Direction indicator lamp bulb - side	
54.6.1	Make and Country of origin (if imported)	
54.6.2	Designation as per AIS-034	
54.7	Front Position Lamp bulb	
54.7.1	Make and Country of origin (if imparted)	
54.7.2	Designation as per AIS-034	
54.8	Rear Position Lamp (tail lamp)Bulb	
54.8.1	Make and Country of origin (if imported)	
54.8.2	Designation as per AIS-034	
54.9	Stop lamp bulb	
54.9.1	Make and Country of origin (if imported)	
54.9.2	Designation as per AIS-034	
54.10	Number plate lamp bulb	
54.10.1	Make and Country of origin (if imported)	
54.10.2	Designation as per AIS-034	
54.11	End out Marker bulb	
54.11.1	Make and Country of origin (if imported)	
54.11.2	Designation as per AIS-034	
54.12	Reversing lamp bulb	
54.12.1	Make and Country of origin (if imported)	
54.12.2	Designation as per AIS-034	
54.13	Stop Lamp Bulb (S3)	
54.13.1	Make and Country of origin (if imported)	
54.13.2	Designation as per AIS-034	
54.14	Front Fog Lamp Bulb	
54.14.1	Make and Country of origin (if imported)	
54.14.2	Designation as per AIS-034	
54.15	Rear Fog Lamp Bulb	
54.15.1	Make and Country of origin (if imported)	
54.15.2	Designation as per AIS-034	
54.16	Side Marker Lamp Bulb	
54.16.1	Make and Country of origin (if imported)	
54.16.2	Designation as per AIS-034	
55.0	Internal Lighting & Illumination	
55.1	Driver Cab lighting :	
55.1.1	Type :	

55.1.2	Name of producer :	
55.1.3	Number :	
55.1.4	Illumination intensity :	
55.2	Passenger Compartment Lighting	
55.2.1	Type :	
55.2.2	Name of producer :	
55.2.3	Number :	
55.2.4	Illumination intensity :	
56.0	Other Area Lighting	
56.1	Type :	
56.2	Name of producer :	
56.3	Number :	
56.4	Illumination intensity :	
57.0	Electrical Circuit	
57.1	Circuit Diagram (attach details):	
58.0	Electrical Cables	
58.1	Name of producer :	
58.2	Conductor Cross section :	
58.3	Insulation Class :	
59.0	Fuse	
59.1	Type & Make	
59.2	Name of producer	
60.0	Master switch for electrical	
60.1	Type & Make	
60.2	Name of producer	

Annexure - II

(See 8.3.1 (c))

(To be submitted by the Vehicle Manufacturer / Body Builder to the Test Agency)

INFORMATION ON VEHICLES CARRYING HAZARDOUS GOODS

1.0	Details of Vehicle Manufacturer	
1.1	Name & address of the vehicle manufacturer	
1.2	Telephone No.	
1.3	Fax. No.	
1.4	E-mail address	
1.5	Contact person	
1.6	Plant(s)of manufacture	
2.0	Details of Truck / Tanker / Bullet Manufacturer	
2.1	Name & address of Truck / Tanker /Bullet Manufacturer	
2.2	Telephone No.	
2.3	Fax. No.	
2.4	E-mail address	
2.5	Contact person	
3.0	Name of model and variants (if any)	
3.1	CMVR certificate reference(s)	
3.2	Type and General commercial description (s)	
4.0	Vehicle type	
4.1	Type of vehicle (rigid / articulated / combination)	
4.2	Usage (goods / passenger / tractor / trailer / others)	
4.3	Control (forward / semi-forward / normal / others)	
4.4	Drive (4x2 / 4x4 / 6x4 / others)	
4.5	Cab type (fully built cab/sleeper cab/cowl/front end structure/with wind shield/without wind shield)	
4.6	Load body, type and drawing	
5.0	Wiring	
5.1	Make	
5.2	Protection type	
6.0	Battery master switch	
6.1	Make	
6.2	Type	
6.3	Model & Identification	

7.0	Battery insulation	
7.1	Make	
7.2	Type	
7.3	Model & Identification	
7.4	Material	
7.5	Nominal thickness	
8.0	Electrical connection	
8.1	Protection degree IP 54 (Yes / No)	
9.0	Tachograph	
9.1	Make	
9.2	Type	
9.3	Model & Identification	
10.0	Exhaust pipe protection	
10.1	Maximum exhaust temperature ⁰ C	
10.2	Description (with a general arrangement drawing of exhaust system along with its routing indicating the lengths of exhaust pipe, tail pipe and exhaust outlet location)	
10.3	Minimum distance between exhaust pipe(s) and the fuel line	
11.0	Speed limitation devices (Governor)	
11.1	Make(s)	
11.2	Type(s)	
11.3	Cut off point under load	
11.4	Max. speed without out load	
11.5	Idle Speed	
12.0	Combustion heater	
12.1	Method of putting off	
13.0	Brakes	
13.1	Type and Brief Description	
13.2	Service brakes	
13.2.1	Name of producer	
13.2.2	Type (Mechanical/hydraulic/air assisted/ vacuum assisted/others)	
13.2.3	Control system & braking wheel	
13.2.4	Schematic layout indicating method of split of brake system, location of valves, reservoirs etc.	

13.3	Anti-Lock braking system Provided (Yes/No)	
13.3.1	If yes, details	
13.3.2	ABS make	
13.4	Electronic Control Unit (ECU)	
13.4.1	Make	
13.4.2	Identification mark	
13.5	Wheel Speed Sensor	
13.5.1	Make	
13.5.2	Identification mark	
13.5.3	No. of sensors used	
13.6	Hydraulic Modulator	
13.6.1	Make	
13.6.2	Identification mark	
13.7	Solenoid Valve	
13.7.1	Make	
13.7.2	Identification mark	
13.7.3	Max. designed pressure, kg/cm ²	
13.7.4	Max. working pressure, kg/cm ²	
13.8	Safety lamp provided (Yes/No)	
13.9	Schematic layout of the ABS system	
13.10	If ASR is used, give details	
13.11	Brake lining (or) Pad	
13.11.1	Nominal Dimensions, (mm) (Length x Width x thickness)	
13.11.1.1	Front wheel	
13.11.1.2	Rear wheel	
13.11.1.3	Others (in case of Tandem axle, give axle wise data)	
13.11.2	Effective area per axle (cm ²)	
13.11.2.1	Front axle	
13.11.2.2	Rear axle	
13.11.2.3	Others (in case of Tandem axle, give axle wise data)	
13.11.3	Material	
13.11.4	Make and Designation	
13.11.4.1	Front wheel / axle	
13.11.4.2	Rear wheel / axle	

13.11.4.3	Others (In case of Tandem axle provide data for each axle)	
13.11.5	Whether asbestos or asbestos-free?	
13.12	Brake drum or disc	
13.12.1	Effective diameter, mm	
13.12.1.1	Front wheel	
13.12.1.2	Rear wheel	
13.12.1.3	Others (in case of tandem axle or articulated trailers)	
13.12.2	Material (if the braking surface is non ferrous)	
13.12.2.1	Front	
13.12.2.2	Rear	
13.12.2.3	Others	
13.13	Master cylinder or brake valve	
13.13.1	Make	
13.13.2	Type	
13.13.3	Inner diameter of the master cylinder, mm	
13.13.4	Operating stroke mm	
13.14	Type of supply tank	
13.15	Wheel cylinder diameter, mm	
13.15.1	Front	
13.15.2	Rear	
13.15.3	Others	
13.16	Wheel cylinder type (single acting/double acting)	
13.16.1	Front	
13.16.2	Rear	
13.16.3	Others	
13.17	Booster	
13.17.1	Name of producer	
13.17.2	Type	
13.17.3	Boost ratio	
13.17.4	Size of the booster, mm (diameter)	
13.17.5	Vacuum or air assistance	
13.17.6	Pressure kg/cm ²	
13.17.6.1	Nominal (P2 as per IS:11852)	
13.17.6.2	Cut in	

13.17.6.3	Cut out			
13.18	Type of vacuum pump or air compressor			
13.19	Type of pressure regulator			
13.20	No. of tanks			
13.20.1	Tank Capacity, lit.	Description	Capacity	
13.20.1.1	Tank 1			
13.20.1.2	Tank 2			
13.20.1.3	Tank 3			
13.20.1.4	Tank 4			
13.21	Brake Chamber	Front	Rear	Parking
13.21.1	Make and type			
13.21.2	Size, mm			
13.21.3	Internal diameter, mm			
13.21.4	Stroke, mm			

Annexure – III

(See Introduction)

COMMITTEE COMPOSITION*
Automotive Industry Standards Committee

Chairperson	
Mrs. Rashmi Urdhwareshe	Director The Automotive Research Association of India, Pune
Members	Representing
Representative from	Ministry of Road Transport and Highways, New Delhi
Representative from	Ministry of Heavy Industries and Public Enterprises (Department of Heavy Industry), New Delhi
Shri S. M. Ahuja	Office of the Development Commissioner, MSME, Ministry of Micro, Small and Medium Enterprises, New Delhi
Shri Shrikant R. Marathe	Former Chairman, AISC
Shri N. K. Sharma	Bureau of Indian Standards, New Delhi
Director/ Shri D. P. Saste (Alternate)	Central Institute of Road Transport, Pune
Director	Indian Institute of Petroleum, Dehra Dun
Director	Vehicles Research and Development Establishment, Ahmednagar
Representatives from	Society of Indian Automobile Manufacturers
Shri T. C. Gopalan	Tractor Manufacturers Association, New Delhi
Shri Uday Harite	Automotive Components Manufacturers Association of India, New Delhi

Member Secretary

Shri A. S. Bhale

General Manager

The Automotive Research Association of India, Pune

* At the time of approval of this Automotive Industry Standard (AIS)