

AMENDMENT NO. 3 (07/2023)
TO
AIS-084 (Part 1)
Automotive Vehicles – Performance requirements of
Demisting Systems of Glazed Surfaces (Windscreen) of
Motor Vehicles

1. Page 1/20, clause 3.3

Substitute following text for existing text of clause 3.3

“3.3 ‘Demisting System’ means the system intended to remove mist on the inside surface of the windscreen;”

2. Page 2/20, clause 3.5.1

Substitute following text for existing text of clause 3.5.1

“3.5.1 Vehicle in running order means kerb weight of the complete vehicle (unladen weight) as defined in cl. 3.6 of IS: 9211 as amended time to time, plus driver and one front seat passenger, the weight of driver and passenger being $75 \text{ kg} \pm 1\%$.”

3. Page 3/20, clause 3.16

Add following clauses 3.17 and 3.18 after clause 3.16

“3.17 ‘demisted area’ means the area of the windscreen having a dry inside surface, without any drops or traces of water, after previously being covered by mist;

3.18 ‘vehicle master control switch’ means the device by which the vehicle’s on-board electronics system is brought from being switched off, as is the case when a vehicle is parked without the driver being present, to normal operation mode.”

4. Page 4/20, clause 6.1.2.3

Substitute following text for existing text of clause 6.1.2.3

“6.1.2.3 If fitted, the engine bonnet, roof, all the doors, windows and the vents, except the intakes and outlets of the heating and ventilation system, shall be closed; one or two windows may be opened from the beginning of the demisting test for a total vertical distance of 25 mm if the vehicle manufacturer so requests.”

5. Page 4/20, clause 6.1.3

Substitute following text for existing text of clause 6.1.3

“6.1.3 The mist shall be produced by means of the steam generator described in Annex V. The generator shall contain enough water to generate at least $70 \pm 5 \text{ g/h}$ of steam for each seating position designated by the manufacturer, in an ambient temperature of $-3 \pm 1^\circ \text{C}$.”

6. Page 4/20, clause 6.1.4

Substitute following text for existing text of clause 6.1.4

“**6.1.4** The inside surface of the windscreen shall be cleaned as prescribed in 6.1.1 once the vehicle placed in the environmental chamber. The ambient air temperature shall then be stabilized at -3 ± 1 °C.

The vehicle shall be switched off and shall be kept at the test temperature for not less than 10 hours prior to commencement of the test. If it is possible to check whether the vehicle’s engine coolant and lubricant (in case of IC engine vehicles) or battery coolant and/or traction motor coolant (in case of hybrid or battery powered vehicles) are stabilized at the test temperature, this period may be shortened.”

7. Page 4/20, clause 6.1.5

Substitute following text for existing text of clause 6.1.5

“**6.1.5** The steam generator shall be placed with its outlets in the median plane of the vehicle at a height of 580 ± 80 mm above the R point or seating reference point of the driver's seat. It shall normally be placed immediately behind the front seat backrest, with the seat-back, if adjustable, set at the prescribed angle. Where the design of the vehicle precludes this, the generator may be placed in front of the backrest, in the nearest convenient position to that mentioned above.”

8. Page 5/20, clause 6.1.6

Substitute following text for existing text of clause 6.1.6

“**6.1.6** After the generator has been operating for five minutes inside the vehicle, one or two observers shall quickly enter the vehicle, opening any access doors for a total duration not exceeding 8 seconds, and be seated on the front seating position(s), the output of the generator being then reduced by 70 ± 5 g/h for each observer.”

9. Page 5/20, clause 6.1.7

Substitute following text for existing text of clause 6.1.7

“**6.1.7** One minute after the observer or observers have entered the vehicle, the engine or the vehicle master control switch shall be started. Subsequently the demisting system shall be activated as indicated by the manufacturer. The test period shall commence as soon as vehicle demisting system has been activated by the observer.”

10. Page 5/20, clause 6.1.7.1

Substitute following text for existing text of clause 6.1.7.1

“**6.1.7.1** If the vehicle is fitted with an engine, it shall run at a speed not exceeding 50 % of the speed corresponding to its maximum power output. However, if this is proven not to be practicable due to specific engine control strategies, for instance in the case of electric hybrid vehicles, a realistic worst-case scenario shall be determined. The scenario shall take into account the engine speeds, periodical absence

or complete absence of a running engine during normal driving conditions at an ambient temperature of – 1 °C. If the system can meet the demisting requirements without a running engine, the engine does not have to run at all.

- 11. **Page 5/20, clause 6.1.7.1.1**
Delete clause 6.1.7.1.1
- 12. **Page 5/20, clause 6.1.7.1.2**
Renumber clause 6.1.7.1.2 as 6.1.7.2 and substitute following text for existing text of clause 6.1.7.1.2
“6.1.7.2 The vehicle’s demisting system controls shall be set as recommended by the vehicle manufacturer for the test temperature.”
- 13. **Page 5/20, clause 6.1.7.1.3**
Renumber clause 6.1.7.1.3 as 6.1.7.3 and substitute following text for existing text of clause 6.1.7.1.3
“6.1.7.3 All batteries shall be fully charged at the start of the test. However, high voltage batteries of vehicles with an electric powertrain shall be charged > 60 %.”
- 14. **Page 5/20, clause 6.1.7.1.4**
Renumber clause 6.1.7.1.4 as 6.1.7.4
- 15. **Page 5/20, clause 6.1.8**
Substitute following text for existing text of clause 6.1.8
“6.1.8. At the end of the test, the demist pattern shall be recorded, noted and marked to identify windscreen vision areas A and B.”
- 16. **Page 6/20, Annex I**
Substitute following text for existing text of Annex I

“ANNEX I
(See 4.2)

**TECHNICAL INFORMATION TO BE SUBMITTED
BY VEHICLE MANUFACTURER**

Relating to the AIS vehicle with regard to windscreen demisting systems.

The following information shall be supplied and include a list of contents. Any drawings shall be supplied in appropriate scale and in sufficient detail on size A4 or on a folder of A4 format. Photographs, if any, shall show sufficient detail.

If the systems, components or separate technical units referred to in this annex have electronic controls, information concerning their performance shall be supplied.

0.	GENERAL
0.1	Make (trade name of manufacturer):
0.2	Model Name and Category of vehicle:

0.3	Name and address of manufacturer:
0.4	Name(s) and address(es) of assembly plant(s):
0.5	Name and address of the manufacturer's representative (if any):
1.1	Manufacturer of the engine:
1.1.1	Manufacturer's engine code (as marked on the engine or other means of identification):
1.2	Internal combustion engine
1.2.1	Specific engine information
1.2.1.1	Working principle: positive ignition/compression ignition Cycle: four stroke/two stroke/rotary
1.2.1.2	Number and arrangement of cylinders:
1.2.1.3	Engine capacity :..... cm ³
1.2.1.4	Normal engine idling speed :.....min ⁻¹
1.2.1.5	Maximum net power :kW at min ⁻¹ (manufacturer's declared value)
1.2.2	Fuel
1.2.2.1	Light-duty vehicles: Diesel/Petrol/LPG/NG or Biomethane/Ethanol (E85)/Biodiesel/Hydrogen
1.2.3	Electrical system
1.2.3.1	Rated voltage:.....V, positive/negative ground
1.2.3.2	Generator
1.2.3.2.1	Type:
1.2.3.2.2	Nominal output:.....VA
1.2.4	Cooling system: liquid/air
1.2.4.1	Nominal setting of the engine temperature control mechanism:
1.2.4.2	Liquid
1.2.4.2.1	Nature of liquid:.....
1.2.4.2.2	Circulating pump(s): Yes/No
1.2.4.2.3	Characteristics:or

1.2.4.2.3.1	Make(s):.....
1.2.4.2.3.2	Type(s):.....
1.2.4.2.4	Drive ratio(s):
1.2.4.2.5	Description of the fan and its drive mechanism:
1.2.4.3	Air
1.2.4.3.1	Fan: yes/no
1.2.4.3.2	Characteristics:or
1.2.4.3.2.1	Make(s):
1.2.4.3.2.2	Type(s):.....
1.3.	Electric motor
1.3.1	Type (winding, excitation)
1.3.1.1	Maximum hourly output:.....kW
1.3.1.2	Operating voltage:V
1.3.2	Battery
1.3.2.1	Number of cells:.....
1.3.2.2	Mass:kg
1.3.2.3	Capacity:Ah (Amp-hours)
1.3.2.4	Position:.....
1.4	Engine or motor combination
1.4.1	Hybrid electric vehicle: Yes/No
1.4.2	Category of hybrid electric vehicle: off-vehicle charging/not off-vehicle charging:
1.4.3	Operating mode switch: with/without
1.4.3.1	Selectable modes
1.4.3.1.1	Pure electric: Yes/No
1.4.3.1.2	Pure fuel consuming: Yes/No
1.4.3.1.3	Hybrid modes: Yes/No (if yes, short description):.....
1.4.4	Description of the energy storage device: (battery, capacitor, flywheel/generator)

1.4.4.1.	Make(s):.....
1.4.4.2	Type(s):.....
1.4.4.3	Identification number (Optional):.....
1.4.4.4	Kind of electrochemical couple:.....
1.4.4.5	Energy: (for battery: voltage and capacity Ah in 2 h, for capacitor: J,)
1.4.4.6	Charger: on board/external/without
2.	Field of vision:
2.1	Particulars of the primary reference marks in sufficient detail to enable them to be readily identified and the position of each in relation to the others and to the R-point to be verified:.....
2.2	Drawing(s) or photograph(s) showing the location of component parts within the 180° forward field of vision:.....
3.0	Windscreen and other windows
3.1	Windscreen
3.1.1	Materials used:.....
3.1.2	Method of mounting:.....
3.1.3	Angle of inclination:
3.1.4	Type-approval number(s): Valid TAC / BIS license no.
3.1.5	Windscreen accessories and the position in which they are fitted together with a brief description of any electrical/electronic components involved:
3.2	Windscreen wiper(s)
3.3	Detailed technical description (including photographs or drawings):
3.4	Windscreen washer
3.4.1	Detailed technical description (including photographs or drawings) or, if approved as separate technical unit, type-approval number:
4.0	Demisting
4.1	Detailed technical description (including photographs or drawings such as Schematic diagram of engine cooling/ heating system):.....
4.2	Blower motor maximum electrical consumption:.....kW
4.3	Interior arrangement (Seating layout)
4.3.1	Layout drawing or photographs showing the X-sectional view of complete air handling system:.....

PRINTED BY
THE AUTOMOTIVE RESEARCH ASSOCIATION OF INDIA
P.B. NO. 832, PUNE 411 004

ON BEHALF OF
AUTOMOTIVE INDUSTRY STANDARDS COMMITTEE

UNDER
CENTRAL MOTOR VEHICLE RULES – TECHNICAL STANDING
COMMITTEE

SET-UP BY
MINISTRY OF ROAD TRANSPORT & HIGHWAYS
(DEPARTMENT OF ROAD TRANSPORT & HIGHWAYS)
GOVERNMENT OF INDIA

13th July 2023

**AMENDMENT NO. 2 August 2013
TO
AIS-084 (Part 1):2008**

**Automotive Vehicles – Performance requirements of
Demisting Systems of Glazed Surfaces (Windscreen) of Motor Vehicles**

1. Page III, Introduction :

Add following text after third para :

“While formulating the standard based on the feedback from Transport Commissioners and customer from hilly area, the standard was restricted to hard top vehicle with doors (Fully enclosed vehicle). Further, based on the test conducted on soft top vehicle during rainy season it was confirmed that there is no problem of mist formation in these vehicles in actual driving conditions. The tests were conducted with partial opening (around 30%) of the flaps / windows.

Hence, soft top and open bodied vehicles have been exempted from the requirement of demisting”

2. Page 1/20, Clause 1.2 :

Add new clause 1.2 as follows, renumber existing clause 1.2 as 1.3 and substitute following text for existing text as given below and renumber subsequent clauses.

“ 1.2 This standard is applicable only to M1 category with hard top and full doors.

1.3 This standard is not applicable to open bodied and soft top vehicles as regards to the requirements of the demisting system.”

3. Page No. 5/20, Clause 7.1 .2 :

Add following text at the end of the sentence.

"For considering whether testing is required or not, guidelines given in Annex VI (Criteria for Extension of Approval) shall be used."

4. Page 20/20, Annex VI :

Insert new Annex VI as given below for existing Annex VI and renumber existing Annex VI as Annex VII.

Annex VI

(See Clause No 7.1.2)

Criteria for Extension of Approvals

Testing is required if		Defrost	Demist	Justification
1	Windscreen Changes – Rake angle, Increase in thickness of 10% of the already tested model	Yes	Yes (only if change in rake angle) No (For Thickness)	a) Change in make does not affect the demisting/defrosting performance. b) The demisting performance is not affected by the change in the thickness of the windscreen. c) Decrease in thickness of the windscreen is actually conducive to the defrosting performance and an increase in thickness up to 10% does not affect the defrosting performance. Similar practice is followed in Europe as well. d) Make does not affect the heating performance, additionally; Thickness will not affect demisting performance.
2 (i)	Reduction in Blower Capacity > 10%	Yes	Yes	Changes other than the blower and heater capacities are not considered to have significant impact
2(ii)	Reduction in heater capacity > 10%	Yes	Yes	
3	Number of seats increase	No	Yes	Only demisting performance is affected. Number of seating positions does not affect defrost testing
4	Decrease in the Cabin Volume in excess of 10% of the already tested model	No	Yes	Only demisting performance is affected The smallest cabin volume is the worst case for the demisting performance as the air inside the smallest cabin volume will attain saturation early and there will be more mist formation.
5	R Points/H Points changes	Yes	Yes	At the time of measurement tolerance for R point and torso angle mentioned in IS 13749:2009 are to be considered
6	Driver Seat Torso Angle	Yes	Yes	
7	Engine rated power (*) reduction > 15%	Yes	Yes	Heat rejection from engine for various power ranges does not vary much for a band of 15 %.

(*) – The same criteria shall be applied to select the vehicle among the variants of CNG/LPG, Petrol and Diesel.

Extension shall be granted without testing for changes other than the above mentioned parameters. Such changes other than the above are not likely to affect the demisting or defrosting performance of the vehicle

In case of multiple combinations of above mentioned parameters, vehicle manufacturer will discuss with test agency to determine whether the test is required or not.

PRINTED BY
THE AUTOMOTIVE RESEARCH ASSOCIATION OF INDIA
P. B. NO. 832, PUNE 411 004
ON BEHALF OF
AUTOMOTIVE INDUSTRY STANDARDS COMMITTEE
UNDER
CENTRAL MOTOR VEHICLES RULES - TECHNICAL STANDING COMMITTEE
SET-UP BY
MINISTRY OF ROAD TRANSPORT & HIGHWAYS
(DEPARTMENT OF ROAD TRANSPORT & HIGHWAYS)
GOVERNMENT OF INDIA

August 2013

AMENDMENT NO. 1
TO
AIS-084(Part 1): 2008
Automotive Vehicles – Performance requirements of
Demisting Systems of Glazed Surfaces (Windscreen) of Motor Vehicles

1. Page 14/20, Annex IV, Table 2, in row 4 and column 2:

Substitute “ -157 mm ” for “ 157 mm”

PRINTED BY
THE AUTOMOTIVE RESEARCH ASSOCIATION OF INDIA
P.B. NO. 832, PUNE 411 004
ON BEHALF OF
AUTOMOTIVE INDUSTRY STANDARDS COMMITTEE
UNDER
CENTRAL MOTOR VEHICLE RULES – TECHNICAL STANDING
COMMITTEE
SET-UP BY
MINISTRY OF ROAD TRANSPORT & HIGHWAYS
(DEPARTMENT OF ROAD TRANSPORT & HIGHWAYS)
GOVERNMENT OF INDIA
March 2011

AIS-084 (Part 1)

AUTOMOTIVE INDUSTRY STANDARD

**Automotive Vehicles - Performance
requirements of Demisting Systems of
Glazed Surfaces (Wind Screen) of
Motor Vehicles**

PRINTED BY
THE AUTOMOTIVE RESEARCH ASSOCIATION OF INDIA
P.B. NO. 832, PUNE 411 004

ON BEHALF OF
AUTOMOTIVE INDUSTRY STANDARDS COMMITTEE

UNDER
CENTRAL MOTOR VEHICLE RULES – TECHNICAL STANDING COMMITTEE

SET-UP BY
MINISTRY OF SHIPPING, ROAD TRANSPORT & HIGHWAYS
(DEPARTMENT OF ROAD TRANSPORT & HIGHWAYS)
GOVERNMENT OF INDIA

June 2008

Status chart of the Standard to be used by the purchaser for updating the record

Sr. No.	Corr-igenda.	Amend-ment	Revision	Date	Remark	Misc.

General Remarks:

INTRODUCTION

The Government of India felt the need for a permanent agency to expedite the publication of standards and development of test facilities in parallel when the work on the preparation of the standards is going on, as the development of improved safety critical parts can be undertaken only after the publication of the standard and commissioning of test facilities. To this end, the erstwhile Ministry of Surface Transport (MOST) has constituted a permanent Automotive Industry Standards Committee (AISC) vide order No.RT-11028/11/97-MVL dated September 15, 1997. The standards prepared by AISC will be approved by the permanent CMVR -Technical Standing Committee (CTSC). After approval, the Automotive Research Association of India, (ARAI), Pune, being the Secretariat of the AIS Committee, has published this standard.

The subject of demisting and defrosting systems was identified in Road Map for Automotive Safety Regulations for formulation of AIS. The formation of mist and frost reduces the driver's visibility, which is important for safety. The purpose of this standard is to ensure good visibility under certain climatic conditions by providing demist and defrost systems for the windscreens.

While formulating the standard and considering climatic conditions in the country and its implementation, the standard is formulated in two parts specifying the requirements for demisting and defrosting systems separately as AIS-084 (Part 1) and AIS-084 (Part 2) respectively.

While preparing this AIS considerable assistance is derived from EEC Directive 78/317/EEC on the approximation of the laws of the Member States relating to the Defrosting and Demisting Systems of Glazed Surfaces of Motor Vehicles.

The Automotive Industry Standards Committee responsible for preparation of this standard is given in Annex : VI

Automotive Vehicles - Performance requirements of Demisting Systems of Glazed Surfaces (Wind Screen) of Motor Vehicles

1. SCOPE

- 1.1. This standard applies to the 180° forward field of vision of the drivers of vehicles in category M1 as defined in AIS-053.
- 1.2. Requirements of demisting systems of this standard are not applicable to the vehicles, which are not sealed from external environment e.g. soft top, open bodied or incomplete vehicle, with agreement of test agency.
- 1.3. Its purpose is to ensure good visibility under certain conditions by specifying the requirements for demisting systems for the windscreens of category M1 vehicles.

2.0 REFERENCES

- 2.1 AIS-053 Automotive Vehicles – Types – Terminology.
- 2.2 AIS-021 Field of Vision of Motor Vehicle Drivers for M1 Category.
- 2.3 IS: 9211-2003 Terms and Definitions of Weights of Road Vehicles other than 2 And 3 Wheelers (Second Revision)

3.0 DEFINITIONS

3.1 Mist

'Mist' means a film of condensate on the inside face of the glazed surfaces.

3.2 Demisting

'Demisting means the elimination of the mist covering the glazed surfaces by the operation of the demisting system.

3.3 Demisting System

'Demisting system' means the system intended to remove a film of condensate on the inside surface of the windscreen and thus restore visibility.

3.4 Vehicle Type

'Vehicle type with regard to the windscreen demisting systems means vehicles which do not differ in such essential respects as:

- 3.4.1 the external and internal forms and arrangements within the area specified in clause 1, which may affect visibility;
- 3.4.2 the shape, size and characteristics of the windscreen and its mounting;
- 3.4.3 the characteristics of the demisting systems;
- 3.4.4 the number of seats.

3.5 Three-dimensional Reference Grid

'Three-dimensional reference grid' means a reference system, which consists of a vertical longitudinal plane X-Z, a horizontal plane X-Y and a vertical transverse plane Y-Z (see Figure 2 of Annex III). The grid is used to determine the dimensional relationships between the position of design points on drawings and their position on the actual vehicle. The procedure for situating the vehicle relative to the grid is specified in Annex III; all co-ordinates referred to ground zero shall be based on a vehicle in running order as defined in 3.5.1.

- 3.5.1 Vehicle in running order means kerb weight of the complete vehicle (unladen weight) as defined in cl. 3.6 of IS: 9211-2003, plus driver and one front seat passenger, the weight of driver and passenger being $75 \text{ kg} \pm 1\%$.
- 3.5.2 Vehicles fitted with suspension enabling their ground clearance to be adjusted shall be tested under the normal conditions of use specified by the vehicle manufacturer.

3.6 Primary Reference Marks

'Primary reference marks' means holes, surfaces, marks and identification signs on the vehicle body. The type of reference mark used and the position of each mark relative to the X, Y and Z co-ordinates of the three-dimensional reference grid and to a design ground plane shall be specified by the vehicle manufacturer. These marks may be the control points used for body-assembly purposes.

3.7 Seat-back Angle

(See Annex II).

3.8 Actual Seat-back Angle

(See Annex II).

3.9 Design Seat-back Angle

(See Annex II).

3.10 V Points

'V points' means points whose position in the passenger compartment is determined by vertical longitudinal planes passing through the centres of the outermost designated seating positions on the front seat and in relation to the R point and the design angle of the seat back, which points are used for verifying compliance with the field-of-view requirements (see Annex IV).

3.11 R Point or Seating Reference Point

(See Annex II).

3.12 H Point

(See Annex II).

3.13 Windscreen Datum Points

'Windscreen datum points' means points situated at the intersection with the windscreen of lines radiating forward from the V points to the outer surface of the windscreen.

3.14 Transparent Area of a Windscreen

'Transparent area of a windscreen' means that area of a vehicle windscreen whose light transmittance, measured at right angles to the surface, is not less than 70%.

3.15 Horizontal Seat-adjustment Range

'Horizontal seat-adjustment range' means the range of normal driving positions designated by the vehicle manufacturer for the adjustment of the driver's seat in the direction of the X axis (see 3.5).

3.16 Extended Seat-adjustment Range

'Extended seat-adjustment range' means the range designated by the vehicle manufacturer for the adjustment of the seat in the direction of the X axis (see 3.5) beyond the range of normal driving positions specified in 3.15 and used for converting seats into beds or facilitating entry into the vehicle.

4.0 TECHNICAL INFORMATION TO BE SUBMITTED BY VEHICLE MANUFACTURER

4.1 The application for type-approval of a vehicle type with regard to its windscreen demisting system shall be submitted by the vehicle manufacturer or by his authorised representative.

4.2 It shall be accompanied by the documents in triplicate and by the particulars as per Annex : I

5. SPECIFIC REQUIREMENTS

5.1. Windscreen Demisting

5.1.1 Every vehicle shall be equipped with a system for removing mist from the interior glazed surface of the windscreen.

5.1.2 The demisting system shall be effective enough to restore visibility through the windscreen in wet weather. Its efficiency shall be verified by the procedure described in 6.1.

- 5.1.3 The following requirements shall be satisfied:
 - 5.1.3.1 the area defined in 2.2 of Annex IV (area A) shall be 90% demisted in 10 minutes;
 - 5.1.3.2 the area defined in 2.3 of Annex IV (area B) shall be 80% demisted in 10 minutes.

6. TEST PROCEDURE

6.1. Windscreen Demisting

- 6.1.1. Before the test, the inside surface of the windscreen shall be thoroughly degreased by means of methylated spirit, or an equivalent degreasing agent. After drying, a solution of ammonia of not less than 3% and not more than 10% shall be applied. The surface shall be allowed to dry again and then be wiped with a dry, cotton cloth.
- 6.1.2. The test shall be carried out in an environmental chamber large enough to take the complete vehicle and capable of producing and maintaining a test temperature of $-3 \pm 1^{\circ}\text{C}$ throughout the test period.
 - 6.1.2.1. The temperature in the test chamber shall be measured at the level of the centre of the windscreen, at a point not significantly affected by heat from the vehicle under test.
 - 6.1.2.2. The horizontal component of the speed of the air cooling the chamber, measured immediately prior to the test, in the median plane of the vehicle at a point 300 mm forward of the base of the windscreen and at a level half-way between the base and the top of the windscreen, shall be as low as possible and in any event less than 8 km/h;
 - 6.1.2.3. The engine bonnet, the doors and the vents, except the intakes and outlets of the heating and ventilation system, shall be closed; one or two windows may be opened from the beginning of the demisting test for a total vertical distance of 25 mm if the vehicle manufacturer so requests.
- 6.1.3. The mist shall be produced by means of the steam generator described in Annex V. The generator shall contain enough water to generate at least 70 ± 5 g/h of steam for each seating position designated by the manufacturer, in an ambient temperature of $-3 \pm 1^{\circ}\text{C}$.
- 6.1.4. The inside surface of the windscreen shall be cleaned as prescribed in 6.1.1 and the vehicle placed in the environmental chamber. The ambient air temperature shall be lowered until the temperature of the engine coolant, the lubricants and the air inside the vehicle are stabilised at $-3 \pm 1^{\circ}\text{C}$.
- 6.1.5. The steam generator shall be placed with its outlets in the median plane of the vehicle at a height of 580 ± 80 mm above the R point of the driver's seat. It shall normally be placed immediately behind the front seat backrest, with the seat-back, if adjustable, set at the prescribed angle. Where the design of the vehicle precludes this, the generator may be placed in front of the backrest, in the nearest convenient position to that mentioned above.

- 6.1.6 After the generator has been operating for five minutes inside the vehicle, one or two observers shall enter the front of the vehicle, the output of the generator being then reduced by 70 ± 5 g/h for each observer.
- 6.1.7 One minute after the observer or observers have entered the vehicle, the engine shall be started as indicated by the manufacturer. The test period shall commence as soon as the engine is running.
 - 6.1.7.1 Throughout the test the engine shall run:
 - 6.1.7.1.1 at a speed not exceeding 50% of the speed corresponding to its maximum power output; moreover,
 - 6.1.7.1.2. the vehicle demister controls shall be set as recommended by the vehicle manufacturer for the test temperature.
 - 6.1.7.1.3. the battery shall be fully charged;
 - 6.1.7.1.4. the voltage at the terminals of the demisting device may be not more than 20% above the nominal rating of the system.
 - 6.1.8. At the end of the test, the demist pattern shall be recorded.

7.0 MODIFICATIONS AND EXTENSION OF APPROVAL FOR DEMISTING SYSTEM

- 7.1 Every modification pertaining to the information, even if the changes are not technical in nature declared in accordance with clause 4, shall be intimated by the manufacturer to the test agency.

If the changes are in parameters not related to the provisions, no further action need be taken.

If the changes are in parameters related to the provisions, the test agency, which has issued the certificate of compliance, may then consider, based on the justification provided by the vehicle manufacturer and reviewed by the test agency, whether,

- 7.1.1 the model with the changed specifications still complies with provisions;
 - or,
- 7.1.2 any further verification is required to establish compliance.
- 7.2. In case of 7.1.2, tests for only those parameters which are affected by the modifications need be carried out.
- 7.3. In case of fulfillment of criterion of clause 7.1.1 or after results of further verification as per clause 7.1.2 are satisfactory, the approval of compliance shall be extended for the changes carried out.

ANNEX I

(See 4.2)

**TECHNICAL INFORMATION TO BE SUBMITTED BY
VEHICLE MANUFACTURER**

1. A description of the vehicle referring to the criteria mentioned in 3.4 of this standard, together with dimensional drawings and either a photograph or an exploded view of the passenger compartment. The numbers and/or symbols identifying the vehicle type shall be specified.
2. Particulars of the primary reference marks in sufficient detail to enable them to be readily identified and the position of each in relation to the others and to the R point to be verified;
3. a technical description of the demisting systems, together with relevant data in sufficient detail.
4. In addition, following technical information shall be submitted by vehicle manufacturer

1.	Manufacturer's name and plant address
2.	Trade name or mark of the vehicle
3.	Complete vehicle kerb weight (unladen weight) as per clause 3.5.1
4.	Test to be conducted: Demisting Systems
5.	Details of demisting systems : i) Schematic diagram of engine cooling system. ii) Schematic diagram of heating system. iii) Cross sectional view of complete air handling system including position of louvers (vents) on dash board. iv) Blower identification and capacity (Watts).
6.	R point w.r.t primary reference marks
7.	Manufacturers recommended seat back angle
8.	Manufacturers recommended driver seat travel distance
9.	Seating Layout
10.	Windscreen glass specifications (type, thickness and make)
11.	Windscreen glass fixing method
12.	Rake angle of windscreen
13.	Engine specification (fuel, capacity cc, engine speed at max. power in rpm).
14.	Rated voltage of electrical installation

ANNEX II

(See 3.7 to 3.9)

PROCEDURE FOR DETERMINING THE H POINT AND THE ACTUAL SEAT-BACK ANGLE AND FOR VERIFYING THE RELATIVE POSITIONS OF THE R AND H POINTS AND THE RELATIONSHIP BETWEEN THE DESIGN SEAT-BACK ANGLE AND THE ACTUAL SEAT-BACK ANGLE

1.0 Annexure : I of AIS-021 shall be applicable.

ANNEX III

(See 3.5 and Annex IV-1.2)

**METHOD FOR DETERMINING THE DIMENSIONAL RELATIONSHIPS
BETWEEN THE VEHICLE'S PRIMARY REFERENCE MARKS AND
THE THREE DIMENSIONAL REFERENCE GRID****1. RELATIONSHIP BETWEEN REFERENCE GRID AND
VEHICLE'S PRIMARY REFERENCE MARKS**

To verify specific dimensions on or within a vehicle submitted for type-approval in accordance with this standard, the relationship between the co-ordinates of the three-dimensional reference grid defined in 3.5 of this standard, which have been laid out at the initial vehicle-design stage, and the positions of the primary reference marks defined in 3.6 of this standard, shall be established accurately so that specific points on the vehicle manufacturer's drawings can be located on an actual vehicle produced from those drawings.

**2. METHOD FOR ESTABLISHING RELATIONSHIP OF
REFERENCE GRID TO REFERENCE MARKS**

For this purpose, a ground reference plane shall be constructed, which is marked with the X-X measurement and the Y-Y measurement. The method of achieving this is set out in Figure 3 of this Annex, the reference plane being a hard, flat, level surface on which the vehicle stands, and which has two measuring scales firmly fixed to its surface; these shall be graduated in millimeters, the X-X scale being not less than 8 m long, and the Y-Y scale not less than 4 m long. The two scales shall be set at right angles to each other as shown in Figure 3 of this Annex. The intersection of the scales is ground zero.

3. EXAMINATION OF THE REFERENCE PLANE

In order to provide for minor variations in the level of the reference plane or test area, it is necessary to measure the deviations from ground zero along both the X and Y scales at intervals of 250 mm and to record the readings obtained so that corrections can be made when checking the vehicle.

4. ACTUAL TEST ATTITUDE

In order to provide for minor changes in suspension height, etc., it is necessary to have available a means of bringing the primary reference marks to the correct co-ordinate positions relative to the design attitude before further measurements are taken. In addition, it shall be possible to make minor lateral and/or longitudinal adjustments to the vehicle's position so as to place it correctly in relation to the reference grid.

5. RESULTS

The vehicle having been correctly placed relative to the reference grid and in its design attitude, the site of the necessary points for studying the forward visibility requirements can be readily determined. Test methods to determine these requirements may include the use of theodolites, light sources or shadow devices, or any other method which can be shown to give equivalent results.

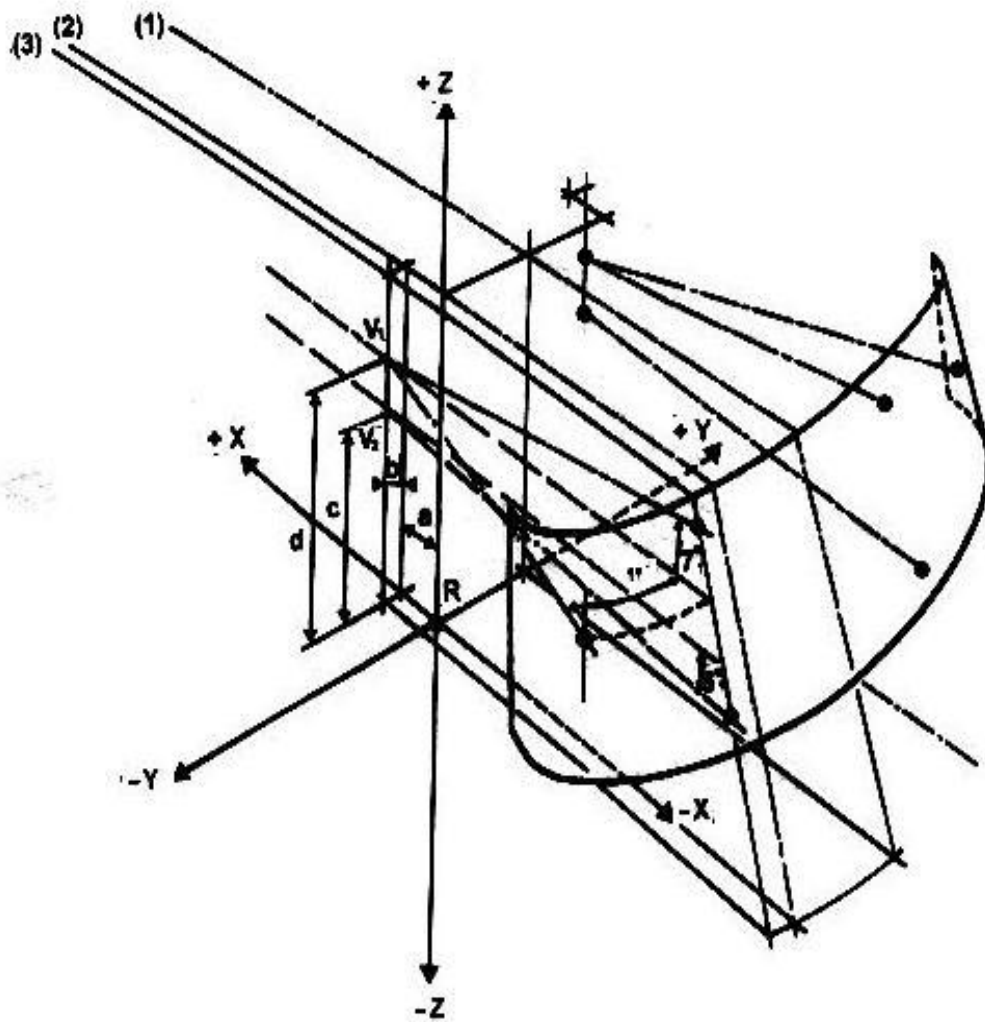

- (1) Line tracing the median longitudinal plane of the vehicle.
- (2) Line tracing the vertical plane passing through R.
- (3) Line tracing the vertical plane passing through V_1 and V_2 .

$a = 68 \text{ mm}$
 $b = 5 \text{ mm}$
 $c = 589 \text{ mm}$
 $d = 665 \text{ mm}$

Figure 1
 Determination of V Points for a Seat-back Angle of 25

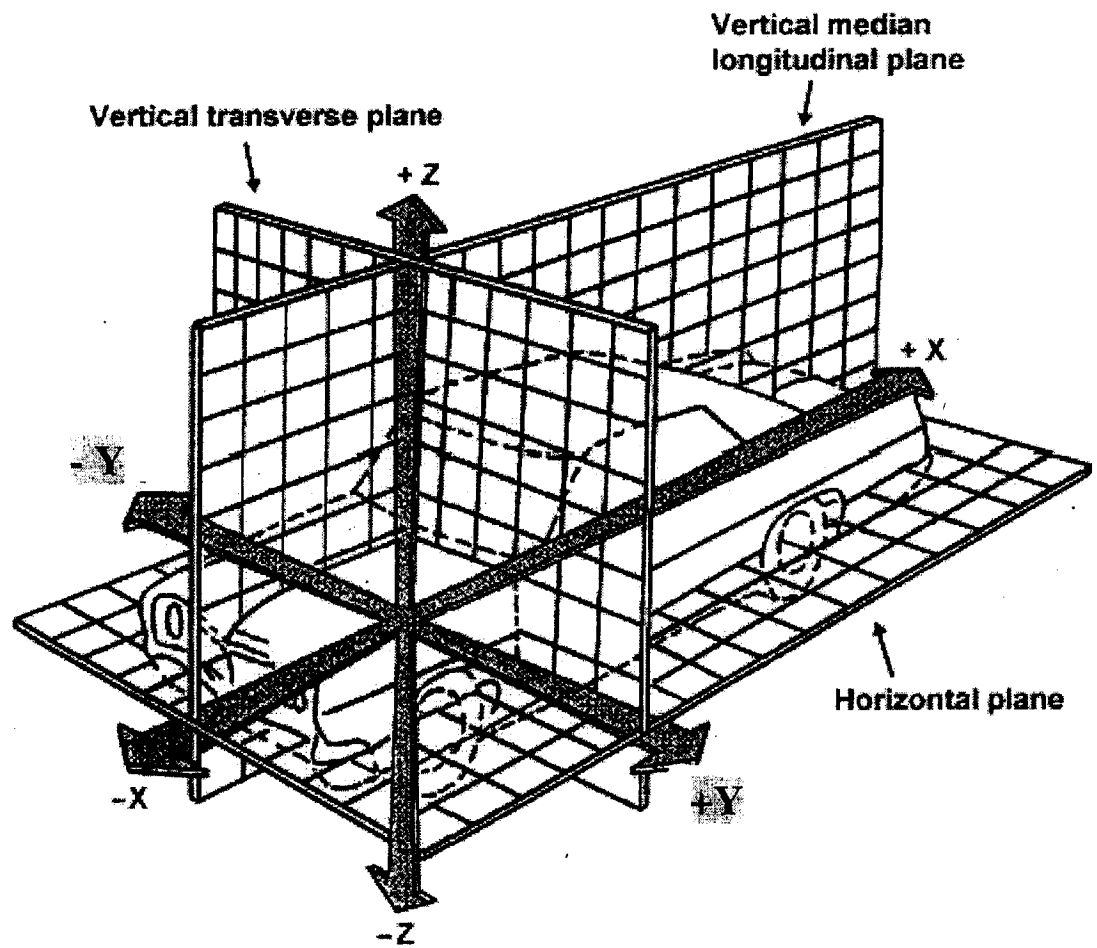

Figure-2
Three-dimensional Reference Grid

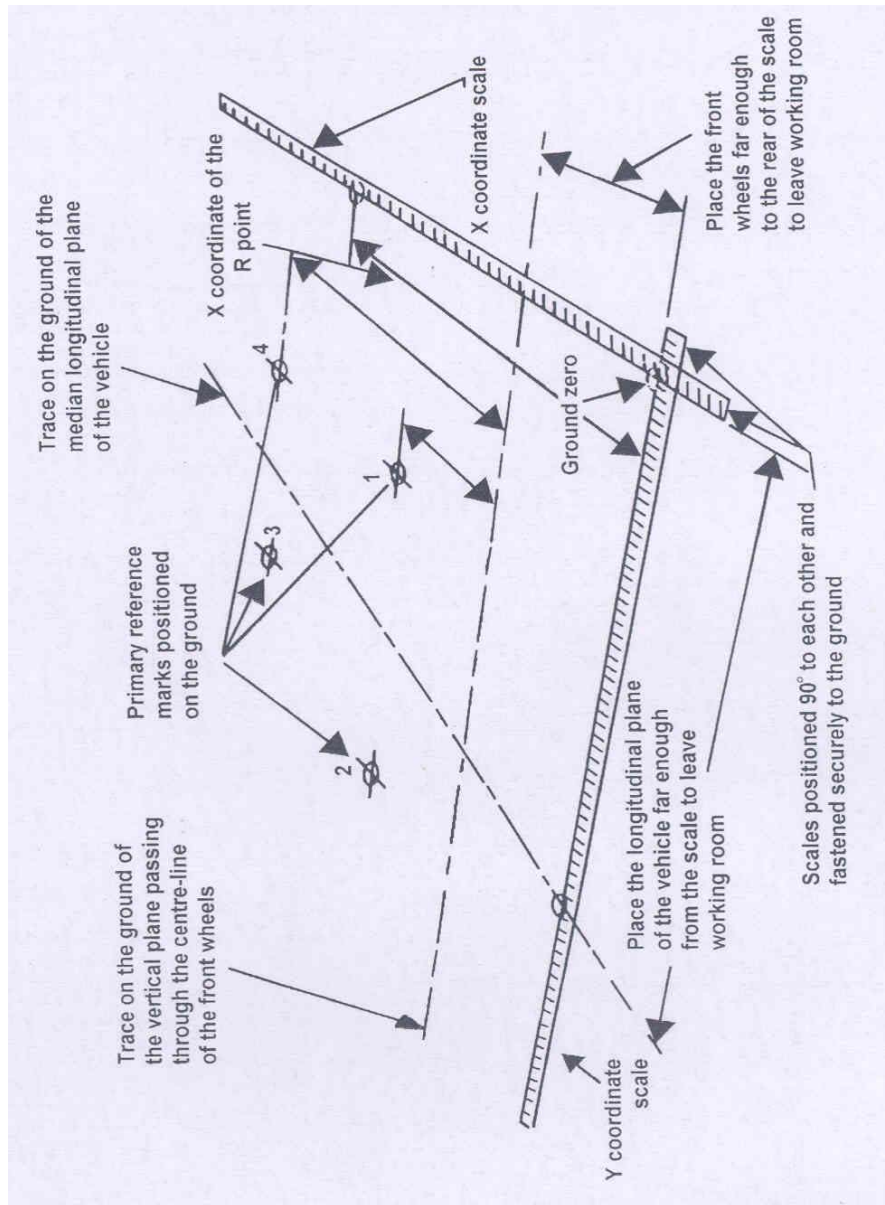

Figure 3
Level Work Space

ANNEX IV

(See 3.10, 5.1.3.1 and 5.1.3.2)

**PROCEDURE FOR DETERMINING VISION AREAS ON
WINDSCREENS OF
CATEGORY M1 VEHICLES IN RELATION TO THE V POINTS**

1. POSITIONS OF THE V POINTS

- 1.1 The positions of the V points in relation to the R point, as indicated by XYZ co-ordinates from the three-dimensional reference grid, are as shown in Tables 1 and 2.
- 1.2 Table 1 indicates the basic co-ordinates for a design seat-back angle of 25°. The positive direction for the co-ordinates is indicated in Figure 1 of Annex III.

Table 1

V point	X	Y	Z
V1	68 mm	- 5 mm	665 mm
V2	68 mm	- 5 mm	589 mm

- 1.3 Correction for Design Seat-back Angles other than 25°
- 1.3.1 Table 2 shows the further corrections to be made to the X and Z co-ordinates of each V point when the design seat-back angle is not 25°. The positive direction for the co-ordinates is shown in Figure 1 of Annex III

Table 2

Seat-back angle (in °)	Horizontal Coordinates ΔX	Vertical coordinates ΔZ	Seat-back angle (in °)	Horizontal angle ΔX	Vertical angle ΔZ
5	-186 mm	28 mm	23	-18 mm	5 mm
6	-177 mm	27 mm	24	- 9 mm	3 mm
7	-167 mm	27 mm	25	0 mm	0 mm
8	157 mm	27 mm	26	9 mm	- 3 mm
9	-147 mm	26 mm	27	17 mm	- 5 mm
10	-137 mm	25 mm	28	26 mm	- 8 mm
11	-128 mm	24 mm	29	34 mm	-11 mm
12	-118 mm	23 mm	30	43 mm	-14 mm
13	-109 mm	22 mm	31	51 mm	-18 mm
14	- 99 mm	21 mm	32	59 mm	-21 mm
15	- 90 mm	20 mm	33	67 mm	-24 mm
16	- 81 mm	18 mm	34	76 mm	-28 mm
17	- 72 mm	17 mm	35	84 mm	-32 mm
18	- 62 mm	15 mm	36	92 mm	-35 mm
19	- 53 mm	13 mm	37	100 mm	-39 mm
20	- 44 mm	11 mm	38	108 mm	-43 mm
21	- 35 mm	9 mm	39	115 mm	-48 mm
22	- 26 mm	7 mm	40	123 mm	-52 mm

2. VISION AREAS

- 2.1. Two vision areas shall be determined from the V points.
- 2.2. Vision area A is the area on the outer surface of the windscreen bounded by the following four planes extending forward from the V point (see Figure 1):
- a vertical plane passing through V1 and V2 and at an angle of 13° to the right of the X axis,
 - a plane parallel to the Y axis passing through V1 and at an upward angle of 3° from the X axis.
 - a plane parallel to the Y axis, passing through V2 and at a downward angle of 1° from the X axis,
 - a vertical plane passing through V1 and V2 and at an angle of 20° to the left of the X axis.

- 2.3.** Vision area B is the area of the outer surface of the windscreen, which is more than 25 mm from the outer edge of the transparent area and is bounded by the intersection of the following four planes with the outer surface of the windscreen (see Figure 2):
- a vertical plane parallel to the Y axis, passing through V1 and at an upward angle of 7° from the X axis,
 - a plane parallel to the Y axis, passing through V2 and at a downward angle of 5° from the X axis,
 - a vertical plane passing through V1 and V2 and at an angle of 17° to the right of the X axis.
 - a plane symmetrical to the former plane in relation to the median longitudinal plane of the vehicle.

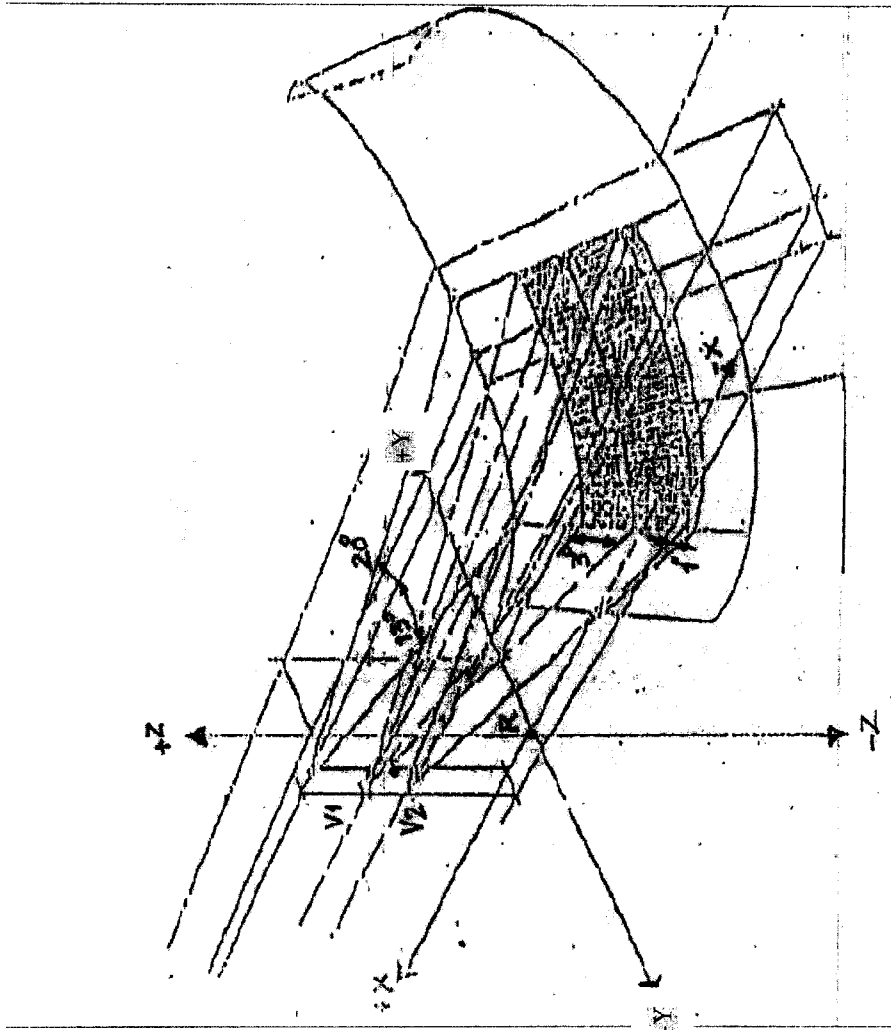

- (1) Line tracing the median longitudinal plane of vehicle.
- (2) Line tracing the vertical plane passing through R.
- (3) Line tracing the vertical plane passing through V1 and V2.

Figure 1
Vision Area A

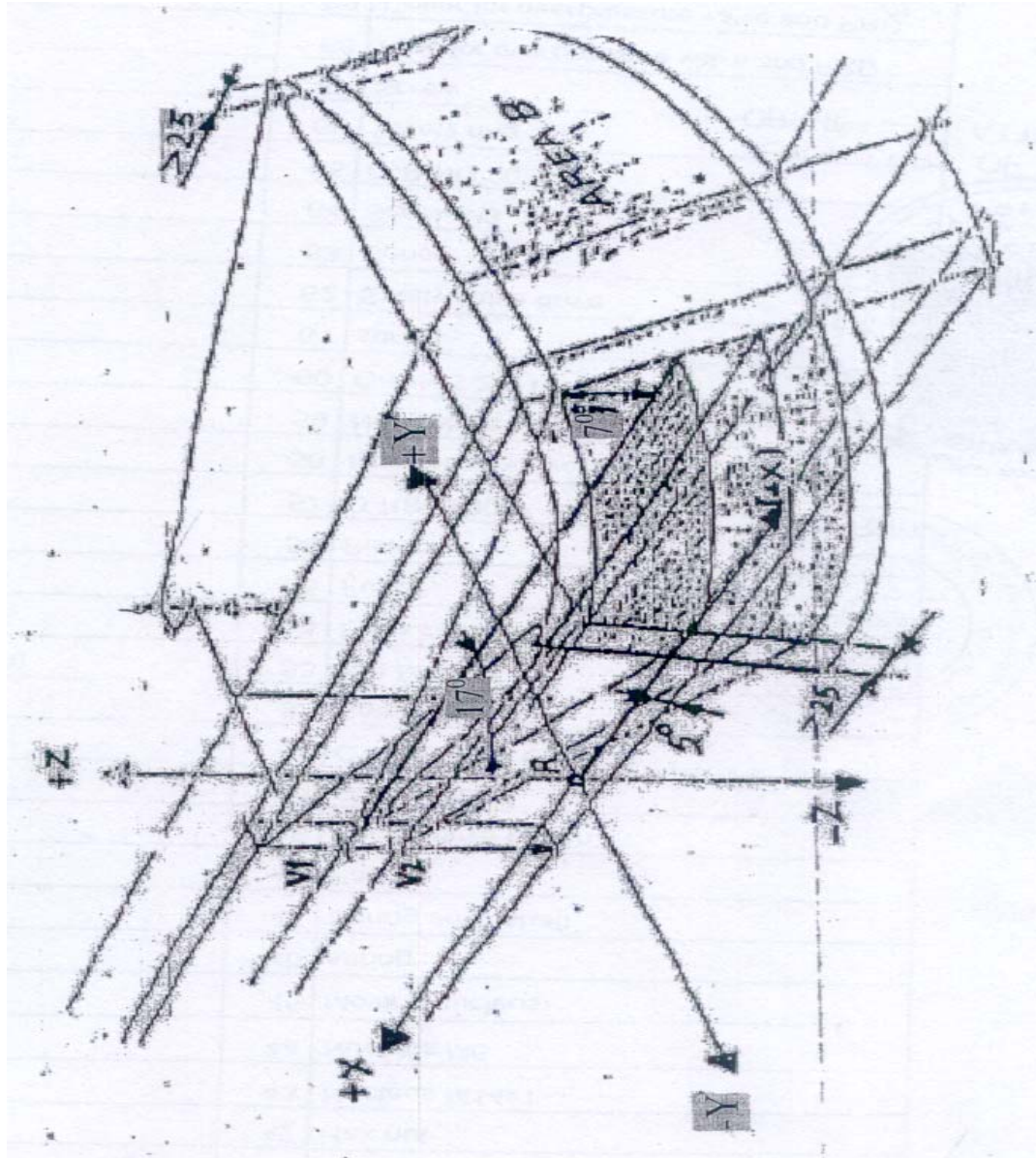

- (1) Line tracing the median longitudinal plane of vehicle.
- (2) Line tracing the longitudinal plane passing through R.
- (3) Line tracing the longitudinal plane passing through V1 and V2.

Figure 2
Vision Area B

ANNEX V

(See 6.1.3)

STEAM GENERATOR

The steam generator used for the test shall have the following characteristics:

- (a) the water container shall have a capacity of at least 2.25 liters;
- (b) the heat loss at boiling point shall not exceed 75 W in an ambient temperature of $-3 \pm 1^\circ \text{C}$;
- (c) the fan shall have a capacity of 0.07 to 0.10 m³/min at 0.5 mbar static pressure;
- (d) six steam outlet holes of 6.3 mm diameter shall be provided round the top of the generator;
- (e) the generator shall be calibrated at $-3 \pm 1^\circ \text{C}$ to give readings for each $70 \pm 5 \text{ g/h}$ output up to a maximum of n times this figure, where n is the number of seating positions designated by the manufacturer.

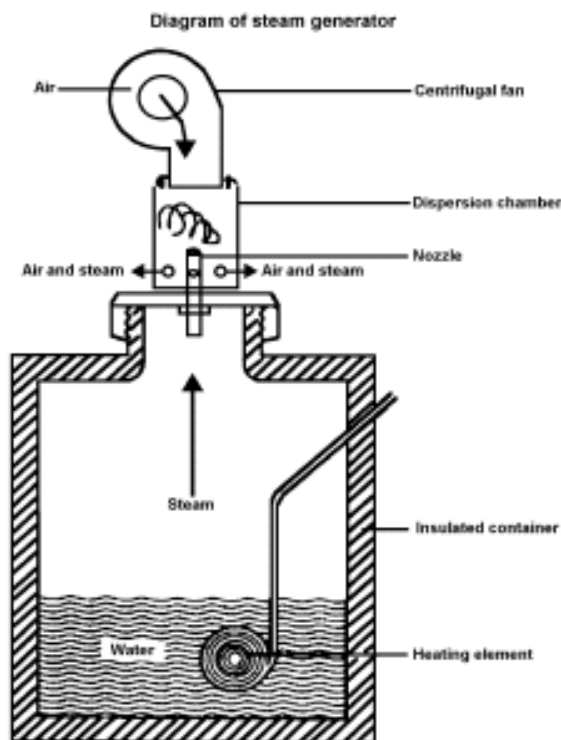

Dimensions and Characteristics of Steam Generator

Component	Dimensions	Material
Nozzle	(a) Length 10 cm (b) Inside diameter 1.5 cm	Brass
Dispersion Chamber	(a) Length 11.5 cm (b) Diameter 7.5 cm (c) Six holes of 0.63 cm evenly spaced 2.5 cm above bottom of the chamber.	Brass pipe of 0.38 mm wall thickness

ANNEX VI
(See Introduction)
COMMITTEE COMPOSITION *
Automotive Industry Standards Committee

Chairman	
Shri Shrikant R. Marathe	Director The Automotive Research Association of India, Pune
Members	Representing
Representative from	Ministry of Shipping, Road Transport & Highways (Dept. of Road Transport & Highways), New Delhi
Representative from	Ministry of Heavy Industries & Public Enterprises (Department of Heavy Industry), New Delhi
Shri Chandan Saha	Office of the Development Commissioner, Small Scale Industries, Ministry of Small Scale Industries, New Delhi
Shri S. M. Bhatia Shri Rakesh Kumar (Alternate)	Bureau of Indian Standards, New Delhi
Prof. A. V. Sardesai Shri D. P. Saste (Alternate)	Central Institute of Road Transport, Pune
Dr. M. O. Garg	Indian Institute of Petroleum, Dehra Dun
Dr. C. L. Dhamejani	Vehicles Research & Development Establishment, Ahmednagar
Representatives from	Society of Indian Automobile Manufacturers
Shri T.C. Gopalan Shri Ramakant Garg (Alternate)	Tractor Manufacturers Association, New Delhi
Shri K.N.D. Nambudiripad	Automotive Components Manufacturers Association, New Delhi
Shri Arvind Gupta	Automotive Components Manufacturers Association, New Delhi

Member Secretary
Mrs. Rashmi Urdhwareshe
Deputy Director

The Automotive Research Association of India, Pune

* At the time of approval of this Automotive Industry Standard (AIS)