

AUTOMOTIVE INDUSTRY STANDARD

**Automotive Vehicles - Installation
Requirements of Lighting and Light-signalling
Devices for Two and Three Wheeled Motor
Vehicles, and E-Rickshaw/E-Cart vehicles,
their Trailers and Semi-Trailers**

(Revision 3)

PRINTED BY
THE AUTOMOTIVE RESEARCH ASSOCIATION OF INDIA
P.B. NO. 832, PUNE 411 004

ON BEHALF OF
AUTOMOTIVE INDUSTRY STANDARDS COMMITTEE

UNDER
CENTRAL MOTOR VEHICLE RULES – TECHNICAL STANDING COMMITTEE

SET-UP BY
MINISTRY OF ROAD TRANSPORT & HIGHWAYS
(DEPARTMENT OF ROAD TRANSPORT & HIGHWAYS)
GOVERNMENT OF INDIA

June 2025

INTRODUCTION

0. The Government of India felt the need for a permanent agency to expedite the publication of standards and development of test facilities in parallel when the work on the preparation of the standards is going on, as the development of improved safety critical parts can be undertaken only after the publication of the standard and commissioning of test facilities. To this end, the erstwhile Ministry of Surface Transport (MOST) has constituted a permanent Automotive Industry Standards Committee (AISC) vide order No. RT-11028/11/97-MVL dated September 15, 1997. The standards prepared by AISC will be approved by the permanent CMVR Technical Standing Committee (CTSC). After approval, the Automotive Research Association of India, (ARAI), Pune, being the Secretariat of the AIS Committee, has published this standard. For better dissemination of this information ARAI may publish this document on their web site.

0.1 Accordingly, AIS-009 covering mandatory requirements regarding Installation of Lighting and Light-signalling devices for 2 and 3 Wheelers, their Trailers and Semi-Trailers has been published in 2001 and has been implemented thereafter in 2004. They were subsequently revised in 2011.

0.2 With technological developments in lighting and light-signalling devices, AIS-009 was taken up for revision and covers requirements regarding Installation of Lighting and Light-signalling Devices for Two and Three Wheeled motor vehicles, and E-Rickshaw/E-cart vehicles, their Trailers and Semi-Trailers

0.3 This part is based on the following ECE Regulations and EEC directives:

ECE R 53 – Supplement 04 to 02 series of amendments and supplement 21 to 01 series of amendments to ECE R 53 Entry into force on 30 th September 2021 and 29 th May 2020 respectively	Uniform provisions concerning the approval of category L3 vehicles with regard to the installation of lighting and light-signalling devices
ECE R 74 – Supplement 13 to the 01 series of amendments Date of Entry into Force: 30 th September 2021	Uniform provisions concerning the approval of: Category L1 vehicles with regard to the installation of lighting and light-signalling devices
EU WVTa Framework Document R (EU) No. 168/2013	Approval and market surveillance of two- or three-wheel vehicles and Quadricycle

0.4 While preparing this standard attempts have been made to align with the above ECE regulations and EEC directive. However, certain changes were necessary in the Indian context.

- 0.5 The following standards contain provisions, which through reference in this text constitute provisions of the standard.
- | | |
|---------------------------------|---|
| IS 14272:2011 | Automotive Vehicles – Types – Terminology |
| AIS-008 (Rev.3): 2022 | Installation Requirements of Lighting and Light-signalling Devices for Motor Vehicle having more than Three Wheels, Trailer and Semi-Trailer excluding Agricultural Tractors |
| AIS-010 (Part 3) (Rev.1) : 2010 | Provisions concerning the Approval of Front position lamps, rear position lamps, stop lamps, direction indicators, rear-registration-plate illuminating devices and Reversing Lamp for vehicles of category L and their Trailers and Semi-trailers. |
| AIS-012 (Part 5) (Rev. 1):2010 | Approval of Direction Indicators for Power-Driven Vehicles and their trailers |
| AIS-034 (Part 2) (Rev.3) :2023 | Provisions Concerning the Approval of Gas discharge Light Sources for use in approved Gas discharge lamp units of power driven vehicles |
| AIS-198:2023 | Uniform provisions Concerning the Approval of Light Signaling Devices and Systems for Power-Driven Vehicles |
| AIS-199:2023 | Uniform provisions concerning the approval of road illumination devices (lamps) and systems for power-driven vehicles |
| AIS-200:2023 | Uniform provisions concerning the approval of retro-reflective devices and markings for power-driven vehicles and their trailers |
| AIS-076:2007 | Approval of Vehicle Alarm Systems (VAS) for M1 and N1 Category of Vehicles and of these Vehicles with regard to their Alarm Systems (AS) |
| AIS-126:2017 | Two Wheeled Motor Vehicles - Location, Identification and Operation of Controls Tell-tales and Indicators |
| IS 11432:2002 | Terms and definitions of dimensions of two wheeled motor vehicles. |
| IS 9435:2004 | Terms and Definitions Relating to Dimensions of Road Vehicles Other than 2 and 3 Wheelers |
- 0.6 The AISC panel responsible for formulation of this standard is given in Annex F
- 0.7 The Automotive Industry Standards Committee (AISC) responsible for approval of this standard is given in Annex G

Clause No.	Contents	Page No.
1.	Scope	1/64
2.	Definitions	1/64
3.	Application for approval	7/64
4.	Approval	8/64
5.	General specifications	8/64
6.	Individual Specification	19/64
7.	Extension of Approval	52/64
8.	Reserved	53/64
9.	Reserved	53/64
10.	Reserved	53/64
11.	Transitional Provisions	53/64
12.	Reserved	53/64
13.	Amendments to ECE regulations after the level described in 0.3 of introduction	53/64
List of Annexes		
Annex A	Technical Specification of Vehicle to be Submitted at the Time of Type Approval	54/64
Annex B	RESERVED	55/64
Annex C	Lamp Surfaces, Axis and Centre of Reference, and Angles of Geometric Visibility	56/64
Annex D	Forward Visibility of Red Lights and Rearward Visibility Of White Lights	58/64
Annex E	Explanation About "The Horizontal Inclination", "The Bank Angle" and the Angle " δ ".	61/64
Annex F	Observing area towards the apparent surface of exterior courtesy lamps	62/64
Annex G	Composition of AISC Panel	63/64
Annex H	Automotive Industry Standards Committee	64/64

Automotive Vehicles - Installation Requirements of Lighting and Light-signaling devices for Two and Three Wheeled Motor Vehicles and E-Rickshaw/E-Cart vehicles, their Trailers and Semi-Trailers

1.0 SCOPE

This standard applies to vehicles of category L1, L2 & L5, and E-rickshaw/E-cart vehicles as defined in IS 14272:2011 as amended from time to time and their trailers and Semi-trailers with regards to the installation of lighting and light-signalling devices.

For the purpose of this standard, the limiting speed of L1 category is 50 km/h instead of 70 km/h.

2.0 DEFINITIONS

For the purpose of this standard the definitions given in the AIS-008 Rev.3 as amended from time to time shall apply, unless otherwise specified in this standard:

- 2.1. **"Approval of a vehicle"** means the approval of a vehicle type with regard to the number and mode of installation of the lighting and light-signalling devices;
- 2.2. **"Vehicle type"** means a category of vehicles which do not differ from each other in such essential respects as:
 - 2.2.1. the dimensions and external shape of the vehicle;
 - 2.2.2. the number and position of the devices;
 - 2.2.3. the following shall likewise not be deemed to be "vehicles of a different type":
 - 2.2.3.1 vehicles which differ within the meaning of clause 2.2.1. and 2.2.2. above but not in such a way as to entail a change in the kind, number, position and geometric visibility of the lamps prescribed for the vehicle type in question; and
 - 2.2.3.2 vehicles on which lamps approved under one of the standards for lighting and light-signalling devices, are fitted, or are absent where their fitting is optional;
- 2.3. **"Transverse plane"** means a vertical plane perpendicular to the median longitudinal plane of the vehicle;
- 2.4. **"Unladen vehicle"** means the vehicle in running order, unoccupied, in the case of liquid fuels, corresponding to 90 per cent of the capacity of the fuel tank specified by the manufacturer, and in the case of gaseous fuels such as CNG, LPG etc. the legally permitted maximum, and coolant, lubricant, tools and

spare wheel, if any.

- 2.5. **"Lamp"** means a device designed to illuminate the road or to emit a light signal to other road users.

Rear registration plate lamp and retro-reflectors are likewise to be regarded as lamps.

- 2.5.1. **"Equivalent lamps"** means lamps having the same function; such lamps may have different characteristics from those of the lamps with which the vehicle is equipped at the time of approval, on condition that they satisfy the requirements of this standard;

- 2.5.2. **"Independent lamps"** means devices having separate apparent surfaces, separate light sources and separate lamp bodies;

- 2.5.3. **"Grouped lamps"** means devices having separate apparent surfaces and separate light sources, but a common lamp body;

- 2.5.4. **"Combined lamps"** means devices having separate apparent surfaces, but a common light source and a common lamp body;

- 2.5.5. **"Reciprocally incorporated lamps"** means devices having separate light sources or a single light source operating under different conditions (for example, optical, mechanical, electrical differences), totally or partially common apparent surfaces and a common lamp body;

- 2.5.6. **"Driving beam (main-beam) headlamp"** means the lamp used to illuminate the road over a long distance ahead of the vehicle;

- 2.5.7. **"Passing beam (dipped-beam) headlamp"** means the lamp used to illuminate the road ahead of the vehicle without dazzling or causing undue discomfort to oncoming drivers and other road users;

- 2.5.7.1 **"Principal passing beam (principal dipped beam)"** means the dipped beam produced without the contribution of infrared (IR) emitters and/or additional light sources for bend lighting.

- 2.5.8. **"Direction-indicator lamp"** means the lamp used to indicate to other road-users that the driver intends to change direction to the right or to the left;

A direction-indicator lamp or lamps may also be used according to provisions of AIS-076 (Vehicle Alarm System).

- 2.5.9. **"Stop lamp"** means the lamp used to indicate to other road-users to the rear of the vehicle that the longitudinal movement of the vehicle is intentionally retarded.

- 2.5.10. **"Rear-registration-plate illuminating device"** means the device used to illuminate the space reserved for the rear registration plate; such a device may consist of several optical components;

- 2.5.11. **"Front position lamp"** means the lamp used to indicate the presence of the vehicle when viewed from the front;
- 2.5.12. **"Rear position lamp"** means the lamp used to indicate the presence of the vehicle when viewed from the rear;
- 2.5.13. **"Retro-reflector"** means a device used to indicate the presence of a vehicle by the reflection of light emanating from a light source not connected to the vehicle, the observer being situated near the source;
- For the purpose of this standard, retro-reflecting number plates are not considered as retro-reflectors;
- 2.5.14. **"Hazard warning signal"** means the simultaneous operation of all of a vehicle's direction-indicator lamps to show that the vehicle temporarily constitutes a special danger to other road users;
- 2.5.15. **"Front fog lamp"** means the lamp used to improve the illumination of the road in case of fog, snowfall, rainstorms or dust clouds;
- 2.5.16. **"Rear fog lamp"** means the lamp used to make the vehicle more easily visible from the rear in dense fog;
- 2.5.17. **"Daytime running lamp"** means a lamp facing in a forward direction used to make the vehicle more easily visible when driving during daytime.
- 2.5.18. **"Interdependent lamp system"** means an assembly of two or three interdependent lamps providing the same function.
- 2.5.18.1 **"Interdependent lamp marked "Y""** means a device operating as part of an interdependent lamp system. Interdependent lamps operate together when activated, have separate apparent surfaces in the direction of the reference axis and separate lamp bodies, and may have separate light source(s).
- 2.5.19. **"Lamps marked "D""** means independent lamps, approved as separate devices in such a way that they are allowed to be used either independently or in an assembly of two lamps to be considered as a "single lamp".
- 2.6. **"Light-emitting surface" of a "lighting device", "light-signalling device" or a retro-reflector** means all or part of the exterior surface of the transparent material as declared in the request for approval by the manufacturer of the device on the drawing, see Annex C;
- 2.7. Illuminating surface" (see Annex C);

- 2.7.1. **"Illuminating surface of a lighting device"** (clause 2.5.6., 2.5.7. and 2.5.15.) means the orthogonal projection of the full aperture of the reflector, or in the case of headlamps with an ellipsoidal reflector of the "projection lens", on a transverse plane. If the lighting device has no reflector, the definition of 2.7.2. shall be applied. If the light emitting surface of the lamp extends over part only of the full aperture of the reflector, then the projection of that part only is taken into account. In the case of a passing beam headlamp, the illuminating surface is limited by the apparent trace of the cut-off on to the lens. If the reflector and lens are adjustable relative to one another, the mean adjustment should be used;

In the case where any combination of a headlamp producing the principal passing-beam and additional lighting units or light sources designed to produce bend lighting are operated together, the individual illuminating surfaces, taken together, constitute the illuminating surface.

- 2.7.2. **"Illuminating surface of a light-signalling device other than a retro-reflector"** (clause 2.5.8., 2.5.9., 2.5.11., 2.5.12., 2.5.14. and 2.5.16.) means the orthogonal projection of the lamp in a plane perpendicular to its axis of reference and in contact with the exterior light-emitting surface of the lamp, this projection being bounded by the edges of screens situated in this plane, each allowing only 98 per cent of the total luminous intensity of the light to persist in the direction of the axis of reference.

To determine the lower, upper and lateral limits of the illuminating surface, only screens with horizontal or vertical edges shall be used;

- 2.7.3 **"Illuminating surface of a retro-reflector"** (clause 2.5.13.) means the orthogonal projection of a retro-reflector in a plane perpendicular to its axis of reference and delimited by planes continuous to the outermost parts of the retro-reflector's optical system and parallel to that axis. For the purposes of determining the lower, upper and lateral edges of the device, only horizontal and vertical planes shall be considered;

- 2.8. **The "Apparent surface"** for a defined direction of observation means, at the request of the manufacturer or his duly accredited representative, the orthogonal projection of:

either the boundary of the illuminating surface projected on the exterior surface of the lens (a-b),

or the light-emitting surface (c-d),

in a plane perpendicular to the direction of observation and tangential to the most exterior point of the lens (see Annex C to this standard);

- 2.9. **"Axis of reference"** (or "reference axis") means the characteristic axis of the lamp determined by the manufacturer (of the lamp) for use as the direction of reference ($H = 0^\circ$, $V = 0^\circ$) for angles of field for photometric measurements and for installing the lamp on the vehicle;
- 2.10. **"Centre of reference"** means the intersection of the axis of reference with the exterior light-emitting surface; it is specified by the manufacturer of the lamp;
- 2.11. **"Angles of geometric visibility"** means the angles which determine the field of the minimum solid angle in which the apparent surface of the lamp shall be visible.

That field of the solid angle is determined by the segments of the sphere of which the centre coincides with the centre of reference of the lamp and the equator is parallel with the ground.

These segments are determined in relation to the axis of reference.

The horizontal angles β , correspond to the longitude and the vertical angles α to the latitude.

- 2.12 **"Extreme outer edge"**, on either side of the vehicle means the plane parallel to the median longitudinal plane of the vehicle and touching the lateral extremity of the vehicle, disregarding the projection or projections:
- 2.12.1. of rear-view mirrors,
- 2.12.2. of direction-indicator lamps,
- 2.12.3. of front and rear position lamps and retro-reflectors;
- 2.13. **"Over-all width"** means the distance between the two vertical planes defined in clause 2.12. above;
- 2.14. **"A single lamp"** means:
- (a) a device or part of a device having one lighting or light-signalling function, one or more light source(s) and one apparent surface in the direction of the reference axis, which may be a continuous surface or composed of two or more distinct parts; or
 - (b) Any assembly of two lamps marked "D", whether identical or not, having the same function, or
 - (c) Any assembly of two independent retro-reflectors, whether identical or not, that have been approved separately; or
 - (d) Any interdependent lamp system composed of two or three interdependent lamps marked "Y" approved together and providing the same function.

- 2.15. **"Distance between two lamps"** which face in the same direction means the shortest distance between the two apparent surfaces in the direction of the reference axis.
- Where the distance between the lamps clearly meets the requirements of the standard, the exact edges of apparent surfaces need not be determined;
- 2.16. **"Operating tell-tale"** means a visual or auditory signal (or any equivalent signal) indicating that a device has been switched on and whether or not it is operating correctly;
- 2.17. **"Circuit-closed tell-tale"** means a visual (or any equivalent signal) indicating that a device has been switched on, but not indicating whether or not it is operating correctly;
- 2.18. **"Optional lamp"** means a lamp, the installation of which is left to the discretion of the manufacturer;
- 2.19. **"Ground"** means the surface on which the vehicle stands which should be substantially horizontal;
- 2.20. **"Device"** means a component or combination of components used in order to perform one or several functions.
- 2.21. **"Colour of the light emitted from the device"**. The definitions of the colour of the light emitted given in AIS-008 Rev.3 in force at the time of application for type approval shall apply to this standard.
- 2.22. **"Gross vehicle mass"** or "maximum mass" means the technically permissible maximum laden mass as declared by the manufacturer.
- 2.23. **"Laden"** means so loaded as to attain the gross vehicle mass as defined in clause 2.22.
- 2.24. **"Type A of L5 category of vehicle"** means an L5 category vehicle whose maximum design speed is not more than 50 km/h and maximum net power does not exceed 4 kW in the case of internal combustion engines or maximum 30 minutes power in the case of an electric motor.
- 2.25. **"Type B of L5 category of vehicle"** means an L5 category vehicle which is not Type A.
- 2.26. **"Longitudinal median plane of vehicle"** as defined in IS 11432:2002 or IS 9435:2004 as applicable to the type of vehicle.
- 2.27. **"Reversing lamp"** means the lamp used to illuminate the road to the rear of the vehicle and to warn other road users that the vehicle is reversing or about to reverse.
- 2.28. **"Horizontal inclination"** means the angle created between the beam pattern when the motorcycle is set as specified in clause 5.4., and the beam pattern when the motorcycle is banked (see drawing in Annex E);

- 2.29 **"Horizontal inclination adjustment system (HIAS)"** means a device that adjusts the horizontal inclination of the headlamp towards zero;
- 2.30 **"Bank angle"** means the angle made with the vertical by the vertical longitudinal median plane of the motorcycle, when the motorcycle is rotated about its longitudinal axis (see drawing in Annex E);
- 2.31 **"HIAS signal"** means any control signal or, any additional control input to the system or, a control output from the system to the motorcycle;
- 2.32 **"HIAS signal generator"** means a device, reproducing one or more of the HIAS signals for system test.;
- 2.33 **"HIAS test angle"** means the angle δ created by the headlamp cut-off line and HH line (in case of an asymmetrical beam headlamp, the horizontal part of the cut-off shall be used), (see drawing in Annex E).
- 2.34 **"Bend lighting"** means a lighting function to provide enhanced illumination in bends.
- 2.35 **"H plane"** means the horizontal plane containing the centre of reference of the lamp.
- 2.36 **"Sequential activation"** means an electrical connection where the individual light sources of a lamp are wired such that they are activated in a predetermined sequence.
- 2.37 **"Emergency stop signal"** means a signal to indicate to other road users to the rear of the vehicle that a high retardation force has been applied to the vehicle relative to the prevailing road conditions.
- 2.38 **"Exterior courtesy lamp"** means a lamp used to provide supplementary illumination to assist the mounting and dismounting of the vehicle driver and passenger or in loading operations.

3.0 APPLICATION FOR APPROVAL

- 3.1. Information to be submitted at the time of applying for type approval shall be as given in Annex A.

Note: If the above information is submitted in a consolidated form, for the type approval of the whole vehicle, it is not necessary to submit this information again.

- 3.2. Reserved.
- 3.2.1. A description of the vehicle type with regard to the items mentioned in paragraphs 2.2.1. to 2.2.3. above; the vehicle type duly identified shall be specified;
- 3.2.2. Reserved.
- 3.2.3. Reserved.

- 3.2.4. If necessary, in order to verify the conformity to the prescriptions of the present standard, a layout drawing or drawings of each lamp showing the illuminating surface, as defined in paragraph 2.7.1. above, the light-emitting surface as defined in paragraph 2.6. above, the axis of reference as defined in AIS-008 Rev. 3 and the centre of reference as defined in AIS-008 Rev.3. This information is not necessary in the case of the rear registration plate lamp (as defined in AIS-008 Rev.3).
- 3.2.5. a statement of the method used for the definition of the apparent surface (paragraph 2.8 above).
- 3.2.6. For L₁ & L₂ Category of Vehicles:

at the discretion of the manufacturer, a statement indicating whether lamps approved for and equipped with LED substitute light sources are allowed to be installed on the vehicle or not and, if this is allowed, which lamps.
- 3.3. An unladen vehicle fitted with a complete set of lighting and light-signalling equipment, as prescribed in Annex A, and representative of the vehicle type to be approved shall be submitted to the testing agency responsible for conducting approval tests.

4.0 APPROVAL

- 4.1 If the vehicle submitted for approval pursuant to this standard meets the requirements of the standard in respect of all the devices specified in the list, approval of that vehicle type shall be granted.
- 4.2. Reserved.
- 4.3. Reserved.
- 4.4. Reserved.
- 4.4.1. Reserved.
- 4.4.2. Reserved.
- 4.5. Reserved.
- 4.6. Reserved.
- 4.7. Reserved.
- 4.8. Reserved.

5.0 GENERAL SPECIFICATIONS

- 5.1. The lighting and light-signalling devices shall be so fitted that in normal conditions of use, and notwithstanding the vibrations to which they may be subjected, they retain the characteristics prescribed by this standard and enable the vehicle to comply with the requirements of this standard.

In particular, it shall not be possible for the lamps to be inadvertently maladjusted.

Note: This is a general requirement and no verification is needed for this to approve the lighting and light-signalling devices for compliance to this standard.

- 5.2. The illuminating lamps shall be so installed that, correct adjustment of their orientation can easily be carried out.
- 5.3. For all light-signalling devices the reference axis of the lamp when fitted to the vehicle shall be parallel to the bearing plane of the vehicle on the road; in addition, it shall be perpendicular to the median longitudinal plane of the vehicle in the case of side retro-reflectors and parallel to that plane in the case of all light-signalling devices. A tolerance of $\pm 3^\circ$ shall be allowed in each direction.

In addition, if specifications for fitting are provided by the manufacturer they shall be complied with.

- 5.4. In the absence of specific instructions, the height and orientation of the lamps shall be verified with the vehicle unladen and placed on a flat horizontal surface, its median longitudinal plane being vertical and the handlebars being in the position corresponding to the straight ahead movement. The tyre pressures shall be those prescribed by the manufacturer for the particular conditions of loading required in this standard.
- 5.5. In the absence of specific instructions:
- 5.5.1. Single lamps or reflectors shall be mounted such that their centre of reference lies in the median longitudinal plane of the vehicle;
- 5.5.2. Lamps constituting a pair and having the same function shall:
- 5.5.2.1. be mounted symmetrically in relation to the median longitudinal plane;
- 5.5.2.2. be symmetrical to one another in relation to the median longitudinal plane;
- 5.5.2.3. satisfy the same colorimetric requirements; and
- 5.5.2.4. have same nominal photometric characteristics;
- 5.5.2.5. come on and go off simultaneously;
- 5.6. Grouped, combined or reciprocally incorporated or single lamps
- 5.6.1. Lamps may be grouped, combined or reciprocally incorporated with one another provided that all requirements regarding colour, position, orientation, geometric visibility, electrical connections and other requirements, if any, are fulfilled.
- 5.6.1.1 The photometric and colorimetric requirements of a lamp shall be fulfilled when all other functions with which this lamp is grouped, combined or

reciprocally incorporated are switched OFF.

However, when a front or rear position lamp is reciprocally incorporated with one or more other function(s) which can be activated together with them, the requirements regarding colour of each of these other functions shall be fulfilled when the reciprocally incorporated function(s) and the front or rear position lamps are switched ON.

5.6.1.2 Stop lamps and direction indicator lamps are not permitted to be reciprocally incorporated.

5.6.1.3 However, where stop lamps and direction indicator lamps are grouped, any horizontal or vertical straight line passing through the projections of the apparent surfaces of these functions on a plane perpendicular to the reference axis, shall not intersect more than two borderlines separating adjacent areas of different colour.

5.6.2. Single Lamps:

5.6.2.1 Single lamps as defined in clause 2.4.11.1 of AIS-008 Rev.3, subparagraph (a), composed of two or more distinct parts, shall be installed in such a way that:

- (a) Either the total area of the projection of the distinct parts on a plane tangent to the exterior surface of the outer lens and perpendicular to the reference axis shall occupy not less than 60 per cent of the smallest quadrilateral circumscribing the said projection; or
- (b) The minimum distance between the facing edges of two adjacent/tangential distinct parts shall not exceed 75 mm when measured perpendicularly to the reference axis.

These requirements shall not apply to a single retro-reflector.

5.6.2.2. Single lamps as defined in paragraph 2.4.11.1 of AIS-008 Rev.3, subparagraph (b) or (c), composed of two lamps marked "D" or two independent retro reflectors, shall be installed in such a way that:

- (a) Either the projection of the apparent surfaces in the direction of the reference axis of the two lamps or retro reflectors occupies not less than 60 per cent of the smallest quadrilateral circumscribing the projections of the said apparent surfaces in the direction of the reference axis; or
- (b) The minimum distance between the facing edges of the apparent surfaces in the direction of the reference axis of two lamps or two independent retro reflectors does not exceed 75 mm when measured perpendicularly to the reference axis.

- 5.6.2.3 Single lamps as defined in paragraph 2.4.11.1 of AIS-008 Rev.3, subparagraph (d), shall fulfil the requirements of paragraph 5.6.2.1.

Where two or more lamps and/or two or more separate apparent surfaces are included into the same lamp body and/or have a common outer lens, these shall not be considered as an interdependent lamp system.

However, a lamp in the shape of a band or strip may be part of an interdependent lamp system.

- 5.7 The maximum height above ground shall be measured from the highest point and the minimum height from the lowest point of the apparent surface in the direction of the reference axis.

For passing beam headlamps, the minimum height from the ground shall be measured from the lowest point of the effective outlet of the optical system (e.g. reflector, lens, projection lens) independent of its utilisation.

Where the (maximum and minimum) height above the ground clearly meets the requirements of the standard, the exact edges of any surface need not be determined.

When referring to the distance between lamps, the position, as regards width, shall be determined from the inner edges of the apparent surface in the direction of the reference axis.

Where the position, as regards width, clearly meets the requirements of the standard, the exact edges of any surface need not be determined.

For the purposes of reducing the geometric visibility angles, the position of a lamp with regard to height above the ground, shall be measured from the H plane.

- 5.8. In the absence of specific instructions, no lamps other than direction-indicator lamps, and the vehicle-hazard warning signal lamps and the emergency stop signal shall be flashing lamps.

- 5.8.1 The photometric characteristics of a direction indicator lamp except for categories 5 and 6 specified in AIS-012 (Part 5) (Rev.1) or AIS-198, and of a direction indicator lamp specified in AIS-010 (Part 3) (Rev.1) or AIS-198 may be varied during a flash by sequential activation of light sources as specified in clause 5.6. of AIS-012 (Part 5) (Rev.1) or paragraph 5.6.11. of AIS-198 or in paragraph 6.8. of AIS-010 (Part 3) (Rev.1)

This provision shall not apply when direction indicator lamps of categories 2a and 2b of AIS-012 (Part 5) (Rev.1) or AIS-198 or category 12 of AIS-010 (Part 3) (Rev.1) or AIS-198 are operated as emergency stop signal according to paragraph 6.19. of this Standard.

- 5.9. No red light which could give rise to confusion shall be emitted from a lamp as defined in clause 2.5. in a forward direction and no white light which could give rise to confusion, shall be emitted from a lamp as defined in clause 2.5.

in a rearward direction. No account shall be taken of lighting devices fitted for the interior lighting of the vehicle. In case of doubt, this requirement shall be verified as follows (see drawing in Annex D):

- 5.9.1 visibility of red light towards the front; a red lamp shall not be directly visible to an observer moving in zone 1 of a transverse plane situated 25 m forward of the foremost point on the vehicle;
- 5.9.2. visibility of white light towards the rear: a white lamp shall not be directly visible to an observer moving in zone 2 of a transverse plane situated 25 m rearward of the rearmost point on the vehicle;
- 5.9.3 in their respective planes, the zones 1 and 2 explored by the eye of the observer are bound:
 - 5.9.3.1 in height, by two horizontal planes 1 m and 2.2 m respectively above the ground;
 - 5.9.3.2 in width, by two vertical planes which, forming to the front and the rear respectively an angle of 15° outwards from the vehicle's median longitudinal plane, pass through the point or points of contact of vertical planes parallel to the vehicle's median longitudinal plane and delimiting the vehicle's over-all width; if there are several points of contact, the foremost shall correspond to the forward plane and the rearmost to the rearward plane.
- 5.9.4 Requirements of clause 5.9 and related s are not applicable in the case of following:
 - (a) White light illuminating the rear registration mark.
 - (b) White light of reversing lamp, if fitted.
 - (c) White light from interior lighting of the vehicle
- 5.10. The electrical connections shall be such that the front position lamp or the passing beam headlamp, if there is no front position lamp, the rear position lamp and the rear-registration-plate illuminating device cannot be switched on or off otherwise than simultaneously unless otherwise specified.

However the above condition is not applicable during the time period between master control switch (Ignition Switch) on and the starting of the engine.

 - 5.10.1 In the case of an interdependent lamp system, all light sources shall be switched on and off simultaneously.

5.11 In the absence of specific instructions, the electrical connection shall be such that the driving beam headlamp, the passing beam headlamp and the fog lamp cannot be switched on unless the lamps referred to in 5.10. above are likewise switched on.

This requirement need not, however, be satisfied in the case of the driving beam headlamp and passing beam headlamp where their luminous warnings consist in switching on the passing beam headlamp intermittently, at short intervals, or in switching on the driving beam headlamp intermittently, or in switching on the passing beam headlamp and driving-beam headlamp alternately at short intervals.

5.11.1 The provisions for automatic operation of Head Lamp / Daytime Running Lamp in the case of L1 and L2 category vehicles shall be as per para (bb) of clause (b) of sub rule 1 of rule 105 (as introduced vide notification number GSR 188 (E) dated 22nd February 2016).

5.12 Tell-tale lamps

5.12.1 Every tell-tale lamp shall be readily visible to a driver in the normal driving position.

5.12.2 Where a "circuit-closed" tell-tale is prescribed by this standard, it may be replaced by an "operating" tell-tale.

5.13 Colours of the lights

The colours of the lights referred to in this standard shall be as follows:

Note: Measurement of the chromaticity coordinates of the light emitted by the lamps is not part of this standard

Driving beam headlamp:	White
Passing beam headlamp:	White
Direction-indicator lamp:	Amber
Stop lamp:	Red
Rear-registration plate lamp:	White
Front position lamp:	White or amber
Rear position lamp:	Red
Rear retro-reflector, non-triangular:	Red
Side retro-reflector, non-triangular:	Amber at the front, Amber or red at the rear

Front retro-reflector, non-triangular:	White
Pedal retro-reflector, non-triangular:	Amber
Vehicle-hazard warning signal:	Amber
Front fog lamp :	White or selective yellow
Rear fog lamp :	Red
Daytime running lamp:	White
Reversing lamp:	White
Emergency Stop Signal :	Amber or Red
Reflective Tape	White at the front and Red at the rear
Exterior courtesy lamp	White

5.14 Every vehicle submitted for approval pursuant to this standard shall be equipped with the following lighting and light-signalling devices:

L2 category	L1 category	L5 category - Type B	L5 category- Type A
Driving beam headlamp (6.1.)	Passing beam headlamp (6.2).	Driving beam headlamp (6.1)	Passing beam headlamp (6.2).
Passing beam headlamp (6.2.)	Rear position lamp (6.7).	Passing beam headlamp (6.2)	Front position lamp (6.6.)
Direction- indicator lamps (6.3.)	Side retro reflectors, non-triangular (6.12.)	Direction- indicator lamps (6.3)	Rear position lamp (6.7.)
Stop lamp, S1 category device specified in AIS-012 (Part 6) (Rev .1) or AIS-199 or stop lamp specified in AIS-010 (Part 3) (Rev.1) (paragraph 6.4.) or stop lamp for category L vehicles in AIS-199;	Rear retro reflector, non-triangular (6.8).	Stop lamp (6.4).	Rear retro reflector, non-triangular (6.8).

Rear- registration-plate illuminating device (6.5.)	Pedal Retro-Reflector in the case of only L1 category of vehicles with pedals. (6.14) (See Note 1)	Rear-registration-plate illuminating device (6.5).	Stop lamp (6.4.)
Rear position lamp (6.7.)	Stop lamp (6.4).	Front position lamp (6.6).	Direction-indicator lamps (6.3.)
Rear retro reflector, non- triangular (6.8.)	Rear-registration-plate illuminating device (6.5).	Rear position lamp(6.7).	Rear-registration-plate illuminating device (6.5.)
Side retro reflectors, non- triangular (6.12.)		Rear retro reflector, non-triangular (6.8).	Reversing lamp (6.16)
		Vehicle-hazard warning signal (6.9)	
		Reversing lamp (6.16)	
		Reflective Tape (6.18)	Reflective Tape (6.18)
Note 1	No component approval is anticipated for pedal reflector.		

5.15

It may, in addition, be equipped with the following lighting and light-signalling devices.

L2 category	L1 category	L5 category- Type B	L5 category - Type A
Vehicle-hazard warning signal (6.9.)	Driving beam headlamp (6.1)	Front Fog lamps. (6.10).	Driving beam headlamp (6.1)
Front fog lamp (6.10.)	Front position lamp (6.6)	Rear Fog lamps (6.11).	Side retro reflectors, non-triangular (6.12.)
Rear fog lamp (6.11.)	Front retro reflectors, non-triangular (6.15)	Side retro reflectors, non-triangular (6.12).	Front Fog lamps. (6.10).
Daytime running lamp. (6.13)	Rear Fog lamps (6.11).	Stop lamp category S3 (High mount stop lamp) (6.17)	Rear Fog lamps (6.11).
Stop lamp, S3 category device specified in AIS-012 (Part 6) (Rev.1) (paragraph 6.4.) or AIS-198	Front Fog lamps. (6.10).		Vehicle-hazard warning signal (6.9)
Front Position Lamp (6.6)	Direction-indicator lamps (6.3) (See Note 2)		

Emergency Stop Signal (6.19)	Stop lamp category S3 (High mount stop lamps) (6.17)		Stop lamp category S3 (High mount stop lamps) (6.17)
Exterior courtesy lamp (6.20)	Vehicle-hazard warning signal (6.9.)		
	Daytime running lamp. (6.13)		

Note 2: For L₁ category vehicles with speed exceeding 25 km/h, the fitment of Direction Indicator Lamps shall be mandatory.

- 5.16 The fitting of each of the lighting and light-signalling devices mentioned in clause 5.15. (when fitted) and clause 5.14. above shall be effected in conformity with the relevant requirements in clause 6 of this standard.
- 5.17. The fitting of any lighting and light-signalling devices other than those mentioned in clause 5.14. and clause 5.15. is prohibited for the purposes of type approval.
- 5.18. Lighting and light-signalling devices type-approved for four-wheeled vehicles of categories M1 and N1 and referred to in clause 5.14. and clause 5.15. above may also be fitted to two and three wheeled motor vehicles and E-rickshaw and E-cart vehicles.
- 5.19 Lighting and light-signalling devices type-approved for 2-wheeled vehicles of L2 category and referred to in clause 5.14. and clause 5.15. above may also be fitted to two wheeled motor vehicles of L1 category.
- 5.20 Rear position lamps, rear direction-indicators and rear retro-reflectors, may be installed on movable components only:
 - 5.20.1 If at all fixed positions of the movable components the lamps on the movable components meet all the position, geometric visibility, colorimetric and photometric requirements for those lamps.
 - 5.20.2 In the case where the functions referred to in clause 5.20. are obtained by an assembly of two lamps marked "D" (see clause **2.4.11.1** of AIS-008 Rev.3), only one of the lamps needs to meet the position, geometric visibility and photometric requirements for those lamps at all fixed positions of the movable components.
 - 5.20.3 Where additional lamps for the above functions are fitted and are activated, when the movable component is in any fixed open position, provided that these additional lamps satisfy all the position, geometric visibility and photometric

requirements applicable to the lamps installed on the movable component.

5.20.4 In the case where the functions referred to in clause 5.20 are obtained by an interdependent lamp system either of the following conditions shall apply:

(a) Should the complete interdependent lamp system be mounted on the moving component(s), the requirements of clause 5.20.1. shall be satisfied. However, additional lamps for the above functions may be activated, when the movable component is in any fixed open position, provided that these additional lamps satisfy all the position, geometric visibility, colorimetric and photometric requirements applicable to the lamps installed on the movable component.

Or

(b) Should the interdependent lamp system be partly mounted on the fixed component and partly mounted on a movable component, the interdependent lamp(s) specified by the Applicant during the device approval procedure shall meet all the position, outwards geometric visibility, colorimetric and photometric requirements for those lamps, at all fixed positions of the movable component(s). The inwards geometric visibility requirement(s) is(are) deemed to be satisfied if this(these) interdependent lamp(s) still conform(s) to the photometric values prescribed in the field of light distribution for the approval of the device, at all fixed positions of the movable component(s).

5.21 General provisions relating to geometric visibility.

5.21.1 There shall be no obstacle on the inside of the angles of geometric visibility to the propagation of light from any part of the apparent surface of the lamp observed from infinity. However, no account is taken of obstacles, if they were already presented when the lamp was type-approved.

5.21.2 If measurements are taken closer to the lamp, the direction of observation shall be shifted parallel to achieve the same accuracy.

5.21.3 If, when the lamp is installed, any part of the apparent surface of the lamp is hidden by any further parts of the vehicle, proof shall be furnished that the part of the lamp not hidden by obstacles still conforms to the photometric values prescribed for the approval of the device.

5.21.4 When the vertical angle of geometric visibility below the horizontal may be reduced to 5 degrees (lamp at less than 750 mm above the ground, measured according to the provisions of clause 5.7.) the photometric field of measurements of the installed optical unit may be reduced to 5 degrees below the horizontal.

5.21.5 In the case of an interdependent lamp system the geometric visibility requirements shall be fulfilled when all its interdependent lamps are operated together.

5.22 All the versions of AIS and Indian standards cross referred here are the latest versions as notified from time to time.

5.23 In the case of E-rickshaw/E-cart vehicles, the lighting and light signalling requirements shall be same as the requirements applicable to ‘Type A of L5 category’ vehicles in this standard with the following exception to the fitment of number of lamps.

5.23.1 Driving beam head lamps as per clause 6.1 (If fitted): Number: One or Two.

5.23.2 Passing beam head lamps as per clause 6.2: Number: One or Two.

5.24. For L₁ Category of Vehicles:

The use of lamps approved for and equipped with LED substitute light source(s), is allowed exclusively in the case where the statement indicated in paragraph 3.2.6. is present and positive.

To verify that this statement is respected, both at the type approval and in the conformity of production verification, the presence of the marking on the lamps related to the use of LED substitute light source(s) shall be checked.

6.0 INDIVIDUAL SPECIFICATIONS

6.1. Driving beam headlamp

6.1.1. Number:

- One or two in case of L2 category
- One or two : If fitted in case of L1 category.
- Two for Type B of L5 category and if fitted for Type A of L5 category.

according to:

6.1.1.1

For L2 category having a cylinder capacity ≤ 125 cm³	L5 category -Type A and L1 category (if fitted)	L5 category-Type B Conditions in AIS 134 – 2016 shall also apply
--	--	--

Driving beam headlamp of Class B, C, D or E of AIS-010 (Part 2) (Rev. 1). OR Class A, B, D, BS, CS, DS or ES of AIS-199	Driving beam headlamp of Class A, B, C, D or E of AIS-010 (Part 2) (Rev. 1) OR Class A, B, BS, CS, DS or ES of AIS-199	Driving beam headlamp of Class B, C, D or E of AIS-010 (Part 2) (Rev. 1) OR Class A, B, BS, CS, DS or ES of AIS-199
OR	OR	OR
Driving beam headlamp of AIS-010 (Part 1) (Rev.1)	Driving beam headlamp class A or B of AIS-010 (Part 1) (Rev.1)	Driving beam headlamp of AIS-010 (Part 1) (Rev.1)
OR		
Driving beam headlamp of AIS-010 (Part 4) (Rev. 1).		

6.1.1.2 For L2 category, having a cylinder capacity > 125 cm³

(a) One or two according to:

Driving beam headlamp of Class B, D or E of AIS-010 (Part 2) (Rev. 1)
or

Class A, B, D, BS, DS or ES of AIS-199

OR

Driving beam headlamp of AIS-010 (Part 1) (Rev. 1) or

Driving beam headlamp of AIS-010 (Part 4) (Rev. 1) or

(b) Two of approved type according to:

Class C of AIS-010 (Part 2) (Rev. 1). Or

Class CS of AIS-199

6.1.2. Arrangement

No special requirement.

6.1.3. Position

6.1.3.1. Width

6.1.3.1.1 an independent driving lamp may be fitted above or below or to one side of another front lamp: if these lamps are on top of the other the reference centre of the driving lamp shall be located within the median longitudinal plane of the vehicle; if these lamps are side by side their reference centre shall be symmetrical in relation to the median longitudinal plane of the vehicle.

6.1.3.1.2 A driving beam headlamp, that is reciprocally incorporated with another front lamp, must be fitted in such a way that its reference centre lies within the median longitudinal plane of the vehicle. However, when the vehicle is also fitted with an independent principal passing beam headlamp, or a principal passing beam headlamp that is reciprocally incorporated with a front position lamp alongside the driving beam headlamp, their reference centres must be symmetrical in relation to the median longitudinal plane of the vehicle.

6.1.3.1.3 two driving lamps of which either one or both are reciprocally incorporated with another front lamp shall be fitted in such a way that their reference centres are symmetrical in relation to the median longitudinal plane of the vehicle.

6.1.3.2 The length: at the front of the vehicle

This requirement is regarded as satisfied if the light emitted does not cause discomfort to the driver either directly or indirectly by means of the rear-view mirrors and/or reflective surfaces on the vehicle.

6.1.3.3 In any case, the distance between the edge of the illuminating surface of any independent driving lamp and the edge of that of the lamp producing the principal passing beam shall not exceed 200 mm. The distance between the edge of the illuminating surface of any independent driving lamp and the ground shall be a minimum of 500 mm and a maximum of 1300 mm.

6.1.3.4. In the case of two driving lamps:

6.1.3.4.1 In the case of L1 and L2 category vehicles, the distance separating the illuminating surfaces of two driving lamps shall not exceed 200 mm.

6.1.3.4.2 In the case of L5 category vehicles, with two driving beam headlamps, the distance between the inner edges of the apparent surfaces in the direction of reference axes shall be minimum of 300 mm when overall width of the vehicle does not exceed 1400 mm and minimum of 500 mm when overall width of the vehicle exceeds 1400 mm.

6.1.3.4.3 In the case of L5 category vehicles, the edges of the apparent surfaces in the direction of the reference axes furthest from longitudinal median plane of vehicle shall not be more than 300 mm from the extreme outer edge of

the vehicle.

6.1.4. Geometric visibility

The visibility of the illuminating surface, including its visibility in areas which do not appear to be illuminated in the direction of observation considered, shall be ensured within a divergent space defined by generating lines based on the perimeter of the illuminating surface and forming an angle of not less than 5° with the axis of reference of the headlamp.

6.1.5. Orientation

6.1.5.1 Forwards. The lamp(s) may move with the steering angle.

6.1.5.2 An HIAS may be installed for the driving beam.

6.1.6. Electrical connections

The driving beam headlamps shall switch on simultaneously. When switching from the passing to the driving beam all of the driving-beam headlamps shall be lit

When switching from the driving beam to the passing beams all of the driving-beam headlamps shall be switched off simultaneously. The passing beam(s) may remain illuminated with the driving beam(s).

6.1.7. Tell Tales

6.1.7.1 "Circuit-closed" tell-tale"

Mandatory. Non-flashing Blue signal lamp.

6.1.7.2 "HIAS failure" tell-tale

Mandatory, flashing amber signal lamp, which may be combined with the tell-tale referred to in clause 6.2.7.2.. It shall be activated whenever a failure is detected with respect to the HIAS signals. It shall remain activated while the failure is present.

6.1.8. Other requirements

6.1.8.1 The aggregate maximum intensity of the driving beam headlamps which can be switched on simultaneously shall not exceed 430,000 cd which corresponds to a reference number of 100. (The approval value).

6.1.8.2. In the event of a driving beam HIAS failure, without the use of any special tools, it shall be possible to:

- (a) deactivate the HIAS until it is reset according to the manufacturer's instructions; and
- (b) re-position the driving beam so that its horizontal and vertical alignments are

the same as a headlamp not equipped with HIAS.

The manufacturer shall provide a detailed description of the procedure for resetting the HIAS.

Alternatively, the manufacturer may choose to install an automatic system that either achieves both the tasks specified above or resets the HIAS. In this case, the manufacture shall provide the test house with a description of the automatic system and, until such time as harmonized requirements have been developed, demonstrate the means of verifying that the automatic system works as described.

6.1.9 The HIAS and bend lighting provisions are applicable for L2 category vehicles (if fitted) and are not applicable for L1 and L5 category vehicles.

6.2. **Passing Beam Headlamp**

6.2.1. Number:

- 6.2.1.1.
- One or two in case of L1 and L2 category.
 - Two in case of L5 category.

according to:

For L2 category having a cylinder capacity $\leq 125 \text{ cm}^3$	L5 category - Type A And L1 category	L5 category -Type B Conditions in AIS 134 – 2016 shall also apply
Passing beam headlamp of Class B, C, D or E of AIS-010 (Part 2) (Rev. 1). Or Class A, B, D, BS, CS, DS or ES of AIS-199	Passing beam headlamp of AIS-010 (Part 2) (Rev. 1). Or Class A, B, AS ^{Note3} , BS, CS, DS or ES of AIS-199	Passing beam headlamp of Class B, C, D or E of AIS-010 (Part 2) (Rev. 1). Or Class A, B, D, BS, CS, DS or ES of AIS-199
OR	OR	OR
Passing beam headlamp of AIS-010 (Part 1)(Rev.1)	Passing beam headlamp class A or B of AIS-010 (Part 1)(Rev.1)	Passing beam headlamp of AIS-010 (Part 1)(Rev.1)
OR		
Passing beam headlamp of AIS-010 (Part 4) (Rev. 1)		

Note 3 : Headlamps of Class A of AIS-010 Part 2 Rev.1 with LED modules or class AS of AIS-199 with LED modules only on vehicles with a maximum design speed not exceeding 25 km/h

6.2.1.2. For L2 category, having a cylinder capacity $> 125 \text{ cm}^3$

(a) One or two according to:

Passing beam headlamp of Class B, D or E of AIS-010 (Part 2) (Rev. 1) or

Class A, B, D, BS, DS or ES of AIS-199 or

Passing beam headlamp of AIS-010(Part 1) (Rev. 1) or;

Passing beam headlamp of AIS-010(Part 4) (Rev.1) or;

(b) Two according to:

Class C of AIS-010(Part 2) (Rev.1). or

Class CS of AIS-199

6.2.2. Arrangement

No special requirement.

6.2.3. Position

6.2.3.1. Width

6.2.3.1.1 An independent passing lamp may be installed above, below or to one side of another front lamp: if these lamps are one above the other the reference centre of the lamp producing the principal passing-beam shall be located within the median longitudinal plane of the vehicle; if these lamps are side by side their reference centre shall be symmetrical in relation to the median longitudinal plane of the vehicle.

6.2.3.1.2 A headlamp producing the principal passing beam that is reciprocally incorporated with another front lamp, shall be fitted in such a way that its reference centre lies within the median longitudinal plane of the vehicle. However, when the vehicle is also fitted with an independent driving beam headlamp, or a driving beam headlamp that is reciprocally incorporated with a front position lamp alongside the headlamp producing the principal passing beam, their reference centres shall be symmetrical in relation to the median longitudinal plane of the vehicle.

6.2.3.1.3 Two headlamps producing the principal passing beam, of which either one or both are reciprocally incorporated with another front lamp shall be installed in such a way that their reference centres are symmetrical in relation to the median longitudinal plane of the vehicle.

6.2.3.1.4 If installed, additional lighting unit(s) which provide bend lighting, type approved as part of the passing-beam according to AIS-010 Part 2 (Rev.1) or AIS-199, shall be installed under the following conditions:

In the case of (a) pair(s) of additional lighting units, they shall be installed so that their reference centre(s) are symmetrical in relation to the median longitudinal plane of the vehicle.

In the case of a single additional lighting unit, its reference centre shall be coincident with the median longitudinal plane of the vehicle.

6.2.3.2 Height: a minimum of 500 mm and a maximum of 1,200 mm above the ground.

6.2.3.3 Length: at the front of the vehicle

This requirement is regarded as satisfied if the light emitted does not cause discomfort to the driver either directly or indirectly by means of the rear-view mirrors and/or reflective surfaces of the vehicle.

6.2.3.4. In the case of two passing-beam headlamps:

6.2.3.4.1 In the case of L1 and L2 category vehicles, the distance separating the illuminating surfaces of two principal passing-beam shall not exceed 200 mm.

6.2.3.4.2 In the case of L5 category vehicles, with two passing beam headlamps, the distance between the inner edges of the apparent surfaces in the direction of reference axes shall be minimum of 300 mm when overall width of the vehicle does not exceed 1400 mm and minimum of 500 mm when overall width of the vehicle exceeds 1400 mm.

6.2.3.4.3 In the case of L5 category, the edges of the apparent surfaces in the direction of the reference axes furthest from longitudinal median plane of vehicle shall not be more than 300 mm from the extreme outer edge of the vehicle.

6.2.4. Geometric visibility

Defined by angles α and β as specified in paragraph 2.10.7. of AIS-008 Rev.3:

α = 15° upwards and 10° downwards;

β = 45° to the left and to the right for a single lamp;

β = 45° outwards and 10° inwards for each pair of lamps.

The presence of partitions or other items of equipment near the headlamp shall not give rise to secondary effects causing discomfort to other road users.

6.2.5. Orientation

6.2.5.1. Forwards

The lamp(s) may move in line with the steering angle.

6.2.5.2 The vertical inclination of the headlamp producing the principal passing beam shall remain between - 0.5 and - 2.5 per cent, except in the case where an external adjusting device is present.

6.2.5.3 For headlamp producing the principal passing beam with a light source having an objective luminous flux which exceeds 2,000 lumens, the vertical inclination of the passing beam headlamp shall remain between - 0.5 and -2.5 per cent.

A headlamp levelling device (manual or automatic) may be used to satisfy the requirements of this.

If manual, it shall be without the use of tools. In such case the manufacturer shall provide in the vehicle owners' manual instruction regarding such manual headlamp levelling.

6.2.5.4 The requirement in clause 6.2.5.3 shall be tested on the vehicle in the following conditions:

Condition A (rider/driver alone):

A mass of 75 kg \pm 1 kg, simulating the rider, shall be placed on the vehicle in such a way as to reproduce the axle loads declared by the manufacturer for this loading condition.

The vertical inclination (initial aiming) of the headlamp producing the principal passing beam shall be set, following the manufacturer's instructions, between -1.0 and -1.5 per cent.

Condition B (fully laden vehicle):

masses, simulating the manufacturer's maximum total mass, shall be placed on the vehicle in such a way as to reproduce the axle loads declared by the manufacturer for this loading condition.

Before making the measurements, the vehicle shall be rocked 3 times up and down and then moved backwards and forwards for at least a complete wheel revolution."

6.2.5.5 An HIAS may be installed for the passing beam. The HIAS shall not adjust the horizontal inclination by more than the vehicle's bank angle.

6.2.5.6 The requirement in clause 6.2.5.5. shall be tested under the following conditions:

The test vehicle shall be set as specified in clause 5.4. Incline the vehicle and measure the HIAS test angle.

The vehicle shall be tested in the following two conditions:

(a) the maximum horizontal inclination adjustment angle specified by the manufacturer (to left and to right);

(b) half of the maximum horizontal inclination adjustment angle specified by the manufacturer (to left and to right).

And when the test vehicle is returned to the position as specified in clause 5.4, the HIAS test angle shall return to zero quickly.

The handlebar may be fixed in the straight ahead position so as not to move during the vehicle inclination.

For the test the HIAS shall be activated by means of an HIAS signal generator.

The system shall be considered to satisfy the requirements of clause 6.2.5.5., if all measured HIAS test angles are not less than zero. This may be demonstrated by the manufacturer using other means accepted by the test agency responsible for type approval.

6.2.5.7 Additional light source(s) or additional lighting unit(s) may be activated only in conjunction with the principal passing-beam or the driving-beam to produce bend lighting. The illumination provided by the bend lighting shall not extend above the horizontal plane that is parallel with the ground and containing the reference

axis of the headlamp producing the principal passing-beam for all bank angles as specified by the manufacturer during type approval of the device according to AIS-010 Part 2 (rev.1) or AIS-199.

6.2.5.8 The requirement in paragraph 6.2.5.7. above shall be tested as follows:

The test vehicle shall be set as specified in clause 5.4. of this Standard. Measure the bank angles on both sides of the vehicle under every condition where the bend lighting is activated. The bank angles to measure are the bank angles specified by the manufacturer during type approval of the device according to AIS-010 Part 2 Rev.1 or AIS-199.

The handlebar may be fixed in the straight ahead position so as not to move during the vehicle inclination.

For the test, the bend lighting may be activated by means of a signal generator provided by the manufacturer.

The system is considered to satisfy the requirements of clause 6.2.5.7. above, if all measured bank angles on both sides of the vehicle are greater than or equal to the minimum bank angles given in the communication form for the type approval of the device according to AIS-010 Part 2 Rev.1 or AIS-199.

Conformity to clause 6.2.5.7. above may be demonstrated by the manufacturer using other means accepted by the Test Agency responsible for type approval.

6.2.6. Electrical connections

The passing -beam headlamps shall switch on simultaneously.

The control for changing over to the passing-beam(s) shall switch off the driving-beam(s) simultaneously. Passing-beam headlamps with a light source approved in accordance with AIS-034 Part 2 Rev.3 shall remain switched on when the driving-beam is illuminated.

6.2.6.1 The additional light source(s) or additional lighting unit(s) used to produce bend lighting shall be so connected that it (they) cannot be activated unless the headlamp(s) producing the principal passing-beam or the driving-beam is (are) also activated.

The additional light source(s) or additional lighting unit(s) used to produce bend lighting on each side of the vehicle may only be automatically activated when the bank angle(s) is(are) greater or equal to the minimum bank angle(s) given in the technical specifications for the type approval of the device according to AIS 010 Part 2 Rev.1 or AIS-199.

However, the additional light source(s) or additional lighting unit(s) shall not be activated when the bank angle is less than three degrees.

The additional light source(s) or additional lighting unit(s) shall be deactivated when the bank angle(s) is (are) less than the minimum bank angle(s) given in the technical specifications for the type approval of the device according to AIS 010 Part 2 Rev.1 or AIS-199.

6.2.7. Tell-tale

6.2.7.1 Optional; non-flashing green signal lamp

"HIAS failure" tell-tale.

6.2.7.2 Mandatory, flashing amber signal lamp, which may be combined with the tell-tale referred to in clause 6.1.7.2. It shall be activated whenever a failure is detected with respect to the HIAS signals. It shall remain activated while the failure is present.

6.2.7.3 In the event of a control system failure, additional light source(s) or additional lighting unit(s) producing bend lighting shall be switched OFF automatically.

6.2.8 Other requirements

In the event of a passing beam HIAS failure, without the use of any special tools, it shall be possible to:

- (a) deactivate the HIAS until it is reset according to the manufacturer's instructions; and
- (b) re-position the passing beam so that its horizontal and vertical alignments are the same as a headlamp not equipped with HIAS.

The manufacturer shall provide a detailed description of the procedure for resetting the HIAS.

Alternatively, the manufacturer may choose to install an automatic system that either achieves both tasks specified above or resets the HIAS. In this case, the manufacture shall provide the test house with a description of the automatic system and, until such time as harmonized requirements have been developed, demonstrate the means of verifying that the automatic system works as described.

6.2.9 The HIAS and bend lighting provisions are applicable for L2 category vehicles (if fitted) not applicable for L1 and L5 category vehicles.

6.3. **Direction indicator lamp**

6.3.1. Number

Two per side.

6.3.2. Arrangement

Two front indicators (category 1 as specified in AIS-012 (Part 5) (Rev.1) or AIS-198 or category 11 specified in AIS-010 (Part 3) (Rev.1) or AIS-198.

Two rear indicators (category 2 as specified in AIS-012 (Part 5) (Rev. 1) or category 12 specified in AIS-010 (Part 3) (Rev.1) or AIS-198

6.3.3. Position

6.3.3.1. in width:

For front indicators, the following requirements shall all be met:

(a) Dimension:

(i) In the case of L1 and L2 categories, there shall be a minimum distance of 240 mm between illuminating surfaces,

(ii) In the case of two wheelers fitted with side car and L5 category vehicles:

The edges of the apparent surfaces in the direction of reference axes furthest from longitudinal median plane shall not be more than 300 mm from the extreme outer edge of the vehicle.

The inner edges of apparent surfaces in the direction of reference axes shall be at least 500 mm apart.

(b) the indicators shall be situated outside the longitudinal vertical plane tangential to the outer edges of the illuminating surface of the driving beam(s) and/or principal passing beam(s),

(c) there shall be a minimum distance between the illuminating surface of the indicators and headlamp producing the principal passing beam headlamp closest to one another as follows: (see figure (a) below)

Minimum indicator intensity (cd)	Minimum separation (mm)
90	75
175	40
250	20
400	≤ 20

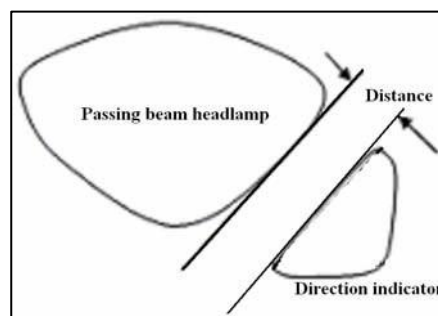

Figure (a)

6.3.3.1.2. For rear indicators

(i) In the case of L1 and L2 category vehicles, the clearance between the inner edges of the two illuminating surfaces shall be at least 180 mm on the

condition that the prescriptions of clause 2.11. are applied even when the registration plate is mounted

(ii) In the case of two wheelers fitted with side car and L5 category vehicles, conditions prescribed in clause 6.3.3.1(a) (ii) shall apply.

6.3.3.2 In height: not less than 350 mm nor more than 1200 mm for L1 and L2 category and 1500 mm in case of L5 category above the ground;

6.3.3.3 In length: the forward distance between the centre reference of the rear indicators and the transverse plane which constitutes the rearmost limit of the vehicle's over-all length shall not exceed 300 mm.

6.3.4. Geometric visibility

Horizontal angles:

20° inwards and 80° outwards for L1 and L2 category and;

45° inwards 80° outwards for L5 category.

Vertical angles: 15° above and below the horizontal.

However, where a lamp is mounted below 750 mm (measured according to the provisions of clause 5.7.), the downward angle of 15° may be reduced to 5°.

6.3.5. Orientation

The front direction-indicators may move in line with the steering angle.

6.3.6. Electrical connections

6.3.6.1 The direction indicator lamps shall switch on independently of the other lamps. All direction indicator lamps on one side of a vehicle shall be switched on and off by means of one control.

6.3.6.2 The direction indicator lamps may be switched ON to indicate the status of the device for protection of vehicles against unauthorized use.

6.3.6.3 The indication described in clause 6.3.6.2. shall be produced by the simultaneous operation of the direction indicator lamps and shall be in accordance to the following conditions.

In case of single indication: 3 seconds maximum

In case of continuous indication:

Duration: 5 minutes maximum

Frequency: (2 ± 1) Hz

On time: Off time \pm 10 per cent

This indication shall be allowed only when the device which starts and/or stops the engine (propulsion system) is set in a position which makes it impossible for the engine (propulsion system) to operate.

6.3.7 "Circuit-closed" tell-tale

Mandatory

Shall be optical or auditory or both. If it is optical, it shall be (a) flashing green lamp(s), which, in the event of defective operation of any of the direction-indicators, is extinguished; remains alight without flashing, or show a marked change of frequency.

6.3.8. Other requirements

The characteristics indicated below shall be measured with no other load on the electrical system than that required for the operation of the engine and the lighting devices.

6.3.8.1 In the case of all vehicles the direction indicator lamps of which are supplied with direct current, the light flashing frequency shall be 90 ± 30 times per minute;

6.3.8.1.1 The flashing of the direction-indicators on the same side of the vehicle may occur synchronously or alternately;

6.3.8.2 Where a vehicle is fitted with direction indicator lamps which are supplied with alternating current, when the engine speed lies between idling and 100% of engine RPM at max. power, declared by the manufacturer, the following condition shall be met:

6.3.8.2.1 The lamps shall flash at a frequency of 90 ± 30 times per minute when the engine speed lies between 50 % and 100 % of the engine RPM at max. power, declared by the manufacturer.

6.3.8.2.2 The lamps shall flash at a frequency between $(90 + 30)$ and $(90 - 45)$ times per minute when the engine speed lies between the idling speed specified by the manufacturer and 50% of the engine RPM at max. power, declared by the manufacturer.

6.3.8.2.3 the flashing of the direction-indicators on the same side of the vehicle may occur synchronously or alternately;

6.3.8.3 Operation of the light-signal control shall be followed within not more than one second by the appearance of the light and within not more than one-and-one half seconds by the first extinction of the light.

6.3.8.4 In the event of failure, other than a short circuit, of one direction- indicator lamp, the other(s) direction-indicator lamp(s) indicating the same direction shall continue to flash or remain alight, but the frequency in this condition may be different from that prescribed.

6.4. Stop lamp

6.4.1. Number

6.4.1.1. One or two for L1 and L2 category vehicles approved as a category S1 device according to AIS 012 (Part 6) (Rev. 1) or AIS-198 or stop lamp according to AIS 010 (Part 3) (Rev.1) or AIS-198.

Optional one approved as a category S3 device according to AIS 012 (Part 6) (Rev. 1) or AIS-198.

6.4.1.2. Two or three in case of two wheelers fitted with side car, one of which shall be on side car

6.4.1.3 Two in the case of L5 category vehicles

6.4.2. Arrangement

No special requirement.

6.4.3. Position

6.4.3.1. Width :

For category S1 device specified in AIS 012 (Part 6) (Rev 1) or AIS-198 or stop lamp specified in AIS 010 (Part 3) (Rev 1) or AIS-198.

In height: not less than 250 mm nor more than 1,500 mm above the ground;

In length: at the rear of the vehicle.

6.4.3.2 For the category S3 device specified in AIS-012 (Part 6) (Rev.1) or AIS-198.

In height: The horizontal plane tangential to the lower edge of the apparent surface shall not be less than 850 mm above the ground.

However, the horizontal plane tangential to the lower edge of the apparent surface shall be above the horizontal plane tangential to the upper edge of the apparent surface of the category S1 device specified in AIS-012 (Part 6) (Rev.1) or AIS-198 or stop lamp specified in AIS-010 (Part 3) (Rev.1) (or stop lamp for category L vehicles of AIS-198.

In length: at the rear of the vehicle.

6.4.3.1.1 In the case of L5 category vehicles with two rear wheels: at least 600 mm between the two lamps. The distance may be reduced to 400 mm of the maximum width if the vehicle is less than 1400 mm.

6.4.3.1.2 In the case of L5 category vehicles with two rear wheels and two wheelers fitted with side cars, the edges of the illuminating surfaces furthest from the median longitudinal plane of the vehicle shall not be more than 300 mm from the outermost part of the vehicle,

6.4.4. Geometric visibility

For category S1 device specified in AIS 012 (Part 6) (Rev.1) or AIS-198 or stop lamp specified in AIS 010 (Part 3) (Rev.1) or AIS-198.

Horizontal angle:

45° to left and to right for a single lamp

45° outwards and 10° for L1 and L2 category vehicles and 30° for L5 category vehicles inwards for each pair of lamps

Vertical angle:

15° above and below the horizontal.

However, where a lamp is mounted below 750 mm (measured according to the provisions of clause 5.7.), the downward angle of 15° may be reduced to 5°.

For category S3 device specified in AIS-012 (Part 6)(Rev.1) or AIS-198

Horizontal angle: 10° to the left and to the right of the longitudinal axis of the vehicle.

Vertical angle: 10° above and 5° below the horizontal.

6.4.5. Orientation

Towards the rear of the vehicle.

6.4.6. Electrical connections

6.4.6.1 All the stop lamps shall light up simultaneously when the braking system provides the braking signal defined in IS-14664 as amended from time to time.

6.4.6.2 The stop lamps need not to function if the device, which starts and/or stops the engine (propulsion system), is in a position that makes it impossible for the engine (propulsion system) to operate.

6.4.7. tell-tale

Tell-tale optional; where fitted, this tell-tale shall be a tell-tale consisting of a non-flashing warning light which comes on the event of the malfunctioning of the stop lamps.

6.4.8. Other requirements

None.

6.5. **Rear-registration-plate illuminating device**

6.5.1. Number

One, approved according to AIS-010 Part 3 Rev. 1 or AIS-198. The device may consist of several optical components designed to illuminate the space reserved for the registration plate

6.5.2 Arrangement

- 6.5.3 Position
 - 6.5.3.1 In width Such that the device illuminates the space reserved for the rear registration plate.
 - 6.5.3.2 In Height
 - 6.5.3.3 In Length
- 6.5.4 Geometric Visibility
- 6.5.5 Orientation
- 6.5.6 Tell Tale
 - Optional, Its function shall be performed by the tell tale prescribed for the position lamp.
- 6.5.7. Other requirements
 - When the rear registration plate lamp is combined with the rear position lamp, reciprocally incorporated in the stop lamp or in the rear fog lamp, the photometric characteristics of the rear registration plate lamp may be modified during the illumination of the stop lamp or the rear fog lamp.
- 6.6. **Front position lamp**
 - 6.6.1. Number
 - 6.6.1.1. For L1 and L2 Category vehicles:
 - One or two if coloured white
 - or
 - Two (one per side) if coloured amber
 - 6.6.1.2. Two or three in case of two wheelers fitted with side car, one of which shall be on side car.
 - 6.6.1.3. Two for L5 category vehicles
 - 6.6.2. Arrangement
 - No special requirement.
 - 6.6.3. Position
 - 6.6.3.1. Width:
 - an independent front position lamp may be fitted above or below, or to one side of another front lamp: if these lamps are one above the other, the reference centre of the front position lamp shall be located within the median longitudinal plane of the vehicle; if these lamps are side by side, their reference

centres shall be symmetrical in relation to the median longitudinal plane of the vehicle;

a front position lamp, that is reciprocally incorporated with another front lamp, shall be installed in such a way that its reference centre is situated in the median longitudinal plane of the vehicle. However, when the vehicle is also fitted with another front lamp alongside the front position lamp, their reference centres shall be symmetrical in relation to the median longitudinal plane of the vehicle.

Two front position lamps, one or both of them reciprocally incorporated with another front lamp, shall be installed in such a way that their reference centres are symmetrical in relation to the median longitudinal plane of the vehicle.

6.6.3.1.1 In the case of two wheelers fitted with side car and L5 category vehicles the edges of the apparent surfaces in the direction of reference axes furthest from longitudinal median plane of vehicle shall not be more than 300 mm from the extreme outer edge of the vehicle.

6.6.3.1.2 In the case of L5 category vehicles, the distance between the inner edges of the apparent surfaces in the direction of reference axes shall be minimum of 400 mm when overall width of vehicle does not exceed 1400 mm and minimum of 600 mm when overall width of vehicle exceeds 1400 mm.

6.6.3.2 in height: not less than 350 mm nor more than 1200 mm above the ground.

6.6.3.3. in length: at the front of the vehicle.

6.6.4. Geometric visibility

Horizontal angle:

80° to left and to right for a single lamp:

the horizontal angle may be 80° outwards and

20° inwards for each pair of lamps in case of L2 category

45° inwards for each pair of lamps in case of L5 category

Vertical angle: 15° above and below the horizontal.

However, where a lamp is mounted below 750 mm (measured according to the provisions of clause 5.7.), the downward angle of 15° may be reduced to 5°.

6.6.5. Orientation

Forwards

The lamp(s) may move in line with the steering angle.

6.6.6. "Circuit-closed" tell-tale

Mandatory

Non-flashing green signal lamp

This tell-tale shall not be required if the instrument illumination lighting can be switched on or off only simultaneously with the position lamp(s).

6.6.7. Other requirements

When the front position lamp is reciprocally incorporated in the front direction indicator lamp, the electrical connection shall be such that the position lamp on the same side as the direction indicator lamp is switched off when the direction indicator lamp is flashing.

6.7 **Rear Position Lamp**

6.7.1. Number

6.7.1.1. One or two for L1 and L2 category

6.7.1.2. Two or three in case of two wheelers fitted with side car, one of which shall be on side car.

6.7.1.3. Two for L5 category

6.7.2. Arrangement

No special requirements.

6.7.3. Position

6.7.3.1. Width

6.7.3.1.1 The reference centre shall be located on longitudinal median plane of the vehicle if there is only one rear position lamp or, if there are two rear position lamps, these shall be symmetrical to longitudinal median plane of the vehicle.

6.7.3.1.2 In the case of vehicles with two rear wheels, and two wheelers fitted with side car, the edges of the apparent surfaces in the direction of the reference axes furthest from longitudinal median plane of vehicle shall not be more than 300 mm from the extreme outer edge of the vehicle.

6.7.3.1.3 For the distance between the inner edges of the two apparent surfaces in the direction of the reference axes, there shall be no special requirement.

6.7.3.2 in height: not less than 250 mm nor more than 1500 mm above the ground

6.7.3.3 in length: at the rear of the vehicle.

6.7.4. Geometric visibility

Horizontal angle: 80° to left and to right for a single lamp:

the horizontal angle may be 80° outwards and 20° inwards for each pair of lamps

Vertical angle: 15° above and below the horizontal

However, where a lamp is mounted below 750 mm (measured according to the provisions of clause 5.7.), the downward angle of 15° may be reduced to 5°.

6.7.5 Orientation

Rearwards

6.7.6. "Circuit-closed" tell-tale

Optional: Its function shall be performed by the device prescribed for the front position lamp.

6.7.7. Other requirements

If a rear position lamp is reciprocally incorporated with a direction indicator, the electrical connection of the rear position lamp on the relevant side of the vehicle or the reciprocally incorporated part of it may be such that it is switched OFF during the entire period (both ON and OFF cycle) of activation of the direction indicator lamp.

6.8 **Rear retro-reflector, non-triangular**

6.8.1. Number

6.8.1.1. One or two of for L1 and L2 category

6.8.1.2. Two for L5 category

6.8.2. Arrangement

No special requirement.

6.8.3. Position

in height: not less than 250 mm nor more than 900 mm above the ground

6.8.4. Geometric visibility

Horizontal angle:

30° to left and to right for a single reflector;

30° outwards and 10° inwards for each pair of reflectors;

Vertical angle: 15° above and below the horizontal.

However, where a lamp is mounted below 750 mm (measured according to the provisions of clause 5.7.), the downward angle of 15° may be reduced to 5°.

6.8.5. Orientation

Rearwards.

6.8.6. Position- Width

6.8.6.1 The reference centre shall be located on longitudinal median plane of the vehicle if there is only one retro-reflector.

If there are two retro-reflectors, these shall be symmetrical to longitudinal median plane of the vehicle.

6.8.6.2 In addition, In the case of two wheelers fitted with a side car and L5 category vehicles, the edges of the illuminating surfaces furthest from longitudinal median plane of vehicle shall not be more than

300 mm from the extreme outer edge of the vehicle. The distance between the inner edges of the illuminating surfaces shall be minimum of 400 mm when overall width of the vehicle does not exceed 1400 mm and minimum of 500 mm when overall width of the vehicle exceeds 1400 mm.

6.9. **Vehicle-hazard warning signal**

6.9.1. The signal shall be given by simultaneous operation of the direction-indicator lamps in accordance with the requirements of clause 6.3. above.

6.9.2. Electrical connections

The signal shall be given by means of a separate control enabling all the direction-indicators to be supplied with current simultaneously. In addition, it may be activated automatically in the event of a vehicle being involved in a collision or after the de-activation of the emergency stop signal, as specified in clause 6.19. below. In such cases, it may be turned OFF manually.

6.9.3. "Circuit-closed" tell-tale

Mandatory

Flashing red signal lamp or, in the case of separate tell-tales, the simultaneous operation of the tell-tale prescribed in clause 6.3.8.

6.9.4. Other requirements

Light flashing 90 ± 30 times per minute.

Operation of the lamp-signal control shall be followed within not more than one second by the appearance of the light and within not more than one-and-one-half seconds by the first extinction of the light.

6.10. **Front fog lamp**

6.10.1. Number

One or two

6.10.2. Arrangement

No special requirement.

6.10.3. Position

6.10.3.1. in width:

a single lamp the centre of reference shall be in the median longitudinal plane of the vehicle; or the edge of the illuminating surface which is nearest to that plane shall be not more than 250 mm away from it;

6.10.3.1.1 In the case of L5 category vehicles with two front fog lamps, the edges of the illuminating surface furthestmost from the median longitudinal plane of the vehicle shall not be further than 400 mm from the outermost edge of the vehicle.

6.10.3.2 in height: not less than 250 mm above the ground

No point on the illuminating surface shall be higher than the highest point on the illuminating surface of the passing beam headlamp.

6.10.3.3 in length: at the front of the vehicle

This requirement shall be deemed to be satisfied if the light emitted does not cause discomfort to the driver either directly, or indirectly through the rear-view mirrors and/or other reflecting surfaces of the vehicle.

6.10.4. Geometric visibility

Defined by angles α and β as specified in paragraph 2.10.7. of AIS-008 Rev.3:

$\alpha=5^\circ$ upwards and downwards

$\beta= 45^\circ$ to left and to right for a single lamp, except for an off-centre light, in which case the inward angle $\beta = 10^\circ$

$\beta= 45^\circ$ outwards and 10° inwards for each pair of lamps

6.10.5. Orientation

Forwards

The lamp(s) may move in line with the steering angle.

6.10.6. May not be combined with any other front lamp.

6.10.7. "Circuit-closed" tell-tale

Optional; non-flashing green signal.

6.10.8. Other Requirements

None

6.10.9. Electrical connections

It shall be possible to switch the fog lamp(s) on or off independently of the driving beam headlamp(s) and/or passing beam headlamp(s).

6.11. **Rear Fog Lamp**

6.11.1. Number

One or two

6.11.2. Arrangement

No special requirement.

6.11.3. Position width:

In the case of L5 category vehicles fitted with two wheels, and two wheelers fitted with side cars, when two rear fog lamps are fitted, the edges of the illuminating surface furthest from the median longitudinal plane of the vehicle shall not be further than 300 mm from the outermost edge of the vehicle. The distance between the inner edges of the illuminating surfaces in the direction of reference shall be minimum of 400 mm when overall width of the vehicle does not exceed 1400 mm and minimum of 600 mm when overall width of the vehicle exceeds 1400 mm.

6.11.3.1. in height: not less than 250 mm nor more than 900 mm in the case of L2 category and two wheelers with side car and 1000mm in case of L5 category vehicles above the ground

6.11.3.2. in length at the rear of the vehicle.

6.11.3.3. the distance between the illuminating surface of the rear fog lamp and that of the stop lamp shall not be less than 100 mm.

6.11.4. Geometric visibility

Defined by angles α and β as specified in paragraph 2.10.7 of AIS-008 Rev.3:

$\alpha=5^\circ$ upwards and downwards

$\beta= 25^\circ$ to left and to right for a single lamp

25° outwards and 10° inwards for each pair of lamps.

6.11.5. Orientation

Rearwards.

6.11.6. Electrical connections

They shall be such that the rear fog lamp can light up only when one or more of the following lamps are switched on: driving beam headlamp, passing beam headlamp, front fog lamp.

If there is a front fog lamp, it shall be possible to switch off the rear fog lamp independently of the front fog lamp.

The rear fog lamp(s) may continue to operate until the position lamps are switched off and they shall remain off until deliberately switched on again.

6.11.7. “Circuit-closed” tell-tale

Mandatory

Non-flashing amber signal lamp.

6.11.8. Other requirements

None.

6.12. **Side retro-reflector, non-triangular**

6.12.1. Number per side

One or two

6.12.2. Arrangement

No special requirement.

6.12.3. Position

6.12.3.1. On the side of the vehicle.

6.12.3.2. In height:

not less than 300 mm nor more than 900 mm above the ground.

6.12.3.3 In length: should be placed in such a position that under normal conditions it may not be masked by the driver's or passenger's clothes.

6.12.4 Geometric Visibility

Horizontal angles $\beta = 30^\circ$ to the front and to the rear.

Vertical angles $\alpha = 15^\circ$ above and below the horizontal.

However, where a lamp is mounted below 750 mm (measured according to the provisions of clause 5.7.), the downward angle of 15° may be reduced to 5° .

6.12.5. Orientation

The reference axis of the retro-reflectors shall be perpendicular to the vehicle's median longitudinal plane and directed outwards. The front side retro-reflectors may move with the steering angle

6.13. **Daytime running lamp**

6.13.1. Presence

Optional

6.13.2. Number

One or two of approved type according to AIS-012 (Part 10) (Rev.1) or AIS-198

6.13.3. Arrangement

No special requirement.

6.13.4. Position

6.13.4.1. In width:

6.13.4.1.1 An independent daytime running lamp may be installed above, below or to one side of another front lamp: If these lamps are one above the other, the reference centre of the daytime running lamp shall be located within the median longitudinal plane of the vehicle; if these lamps are side by side, the edge of the illuminating surface shall not be more than 250 mm from the median longitudinal plane of the vehicle.

6.13.4.1.2 A daytime running lamp, that is reciprocally incorporated with another front lamp (driving beam headlamp or front position lamp), shall be fitted in such a way that the edge of the illuminated surface lies not more than 250 mm from the median longitudinal plane of the vehicle.

6.13.4.1.3 Two daytime running lamps, of which either one or both are reciprocally incorporated with another front lamp, shall be installed in such a way that their reference centres are symmetrical in relation to the median longitudinal

plane of the vehicle.

6.13.4.1.4 In the case of two daytime running lamps, the distance separating the illuminating surfaces shall not exceed 420 mm.

6.13.4.1.5 The maximum separation distance is not applicable when the daytime running lamps:

(a) are grouped, combined or reciprocally incorporated with another headlamp,

or

(b) are within the projection of the frontal silhouette of the motorcycle on an orthogonal plane perpendicular to the longitudinal median plane of the vehicle."

6.13.4.2 In height

Above the ground not less than 250 mm and not more than 1500 mm.

6.13.4.3. In length:

At the front of the vehicle.

6.13.5. Geometric visibility

Horizontal angle: outwards 20° and inwards 10°.

Vertical angle: upwards 10° and downwards 10°.

6.13.6. Orientation

Towards the front. The lamp(s) may move in line with the steering angle.

6.13.7. Electrical connections

6.13.7.1 The daytime running lamp shall switch OFF automatically when the headlamps are switched ON, except when the latter are used to give intermittent luminous warnings at short intervals.

The rear position lamp shall be switched ON when the daytime running lamp(s) is/are switched ON.

The front position lamp(s), if fitted and the rear-registration-plate illuminating device may be switched ON

individually or together, when the daytime running lamp(s) is/are switched ON.

However the above condition is not applicable during the time period between master control switch

(Ignition Switch) ON and the starting of the engine.

- 6.13.7.2 If the distance between the front direction-indicator lamp and the daytime running lamp is equal or less than 40 mm, the electrical connections of the daytime running lamp on the relevant side of the vehicle may be such that either
- (a) it is switched OFF or
 - (b) its luminous intensity is reduced during the entire period (both ON and OFF cycle) of activation of a front direction- indicator lamp.
- 6.13.7.3 If a direction indicator lamp is reciprocally incorporated with a daytime running lamp, the electrical connections of the daytime running lamp on the relevant side of the vehicle shall be such that the daytime running lamp is switched OFF during the entire period (both ON and OFF cycle) of activation of the direction-indicator lamp.
- 6.13.8. Tell-tale
- Closed-circuit green tell-tale, optional
- 6.13.9 Other Requirements
- The DRL symbol in ISO 2575: 2004 Road vehicles. Symbols for controls, indicators and tell-tales, may be used to inform the driver that the daytime running lamp is on
- 6.14. **Pedal retro-reflectors**
- 6.14.1 Number
- Four retro-reflectors or retro-reflector groups.
- 6.14.2 Arrangement
- No special requirement.
- 6.14.3 Other Requirements
- The outer faces of the illuminating surface of the retro-reflectors shall be recessed into the body of the pedal.
- The retro-reflectors shall be mounted in the pedal body in such a way as to be clearly visible both to the front and to the rear of the vehicle. The reference axis of such retro-reflectors, the shape of which shall be adapted to that of the pedal body, shall be perpendicular to the pedal axis.
- Pedal retro-reflectors shall be fitted only to those pedals of the vehicle which, by means of cranks or similar devices, can be used to provide a means of propulsion alternative to the engine.
- They shall not be fitted to pedals which serve as controls for the vehicle or which serve only as footrests for the rider or passenger.

They shall be visible to the front and the rear.

6.15. **Front retro-reflector, non-triangular**

6.15.1. Number

One

6.15.2. Arrangement

No special requirement.

6.15.3. Position

in height: not less than 400 mm nor more than 1200 mm above the ground

6.15.4. Geometric Visibility

Horizontal angle: 30° to the left and to the right.

Vertical angle: 15° above and below the horizontal.

The vertical angle below the horizontal may be reduced to 5°, however, if the height of the reflector is less than 750 mm.

6.15.5. Orientation

Forwards. The reflector may move in line with the steering angle.

6.15.6. Other requirements

None

6.16. **Reversing lamp**

6.16.1 Number: one or two

6.16.2 Arrangement: no individual specifications

6.16.3 Position

6.16.3.1 Width: In case of two reversing lamps, they shall be mounted at rear, symmetrical with respect to longitudinal median plane of the vehicle. If there is only one, it may be mounted to one side of the vehicle at rear.

6.16.3.2 Height: minimum 250 mm, maximum 1200 mm above the ground.

6.16.3.3 Length: at the rear of the vehicle.

6.16.4 Geometric Visibility

Defined by angles α and β as specified in clause 2.11

$\alpha = 15^\circ$ upwards and 5° downwards

$\beta = 45^\circ$ to the right and to the left if there is only one reversing lamp

$\beta = 45^\circ$ outwards and 30° inwards if there are two reversing lamps.

6.16.5 Alignment: towards the rear.

6.16.6 a) May be grouped with any other rear lamp.

b) May not be combined with any other lamp.

c) May not be reciprocally incorporated with another lamp.

6.16.7 Electrical Connections

Reversing lamp shall light up on engagement of reverse gear. However, it need not light up before the engine is started.

6.16.8 Circuit-closed tell-tale

Optional.

6.17. **Stop lamp category S3 (high mount stop lamp)**

6.17.1. Number : One

6.17.2. Arrangement: No special requirement

6.17.3. Position

The centre of reference shall be situated on the median longitudinal plane of the vehicle

6.17.4. Height

Wherever applicable the horizontal plane tangential to the lower edge of the apparent surface shall either :

a) not be more than 150 mm below the horizontal plane tangential to the lower edge of the exposed surface of the glass or glazing of the rear window, or

b) not be less than 850 mm above the ground.

6.17.5. Length : no special requirement.

6.17.6. Geometric visibility

$\beta = 10$ degrees to the left and right of the longitudinal axis of the vehicle.

$\alpha = 10$ degrees above and 5 degrees below the horizontal.

- 6.17.7. Orientation : Towards the rear of the vehicle.
- 6.17.8. Electrical connections: Same as clause 6.4.6.
- 6.17.9. Tell-tale: Same as clause 6.4.7.
- 6.17.10. Other requirements
 - 6.17.10.1 The device shall not be reciprocally incorporated with any other lamp.
 - 6.17.10.2 Wherever applicable the device shall be installed outside or inside the vehicle. In the case where it is installed inside the vehicle, the light emitted shall not cause discomfort to the driver through the rear-view mirrors and/or other surfaces of the vehicle (i.e. rear window).
- 6.18 **Reflective Tape**
 - 6.18.1 Arrangement:
 - 6.18.1.1 At the front:

White Reflective tape of width not less than 20 mm conforming to Annexures 4, 5 and 6 of AIS: 090-2005.
 - 6.18.1.2 At the rear:

Red Reflective tape of width not less than 20 mm conforming to Annexures 4, 5 and 6 of AIS: 090-2005.
 - 6.18.1.3. The Reflective Tape shall be as close as practicable to horizontal, compatible with the shape, structure, design and operational requirements of the vehicle.
 - 6.18.2. Position:
 - 6.18.2.1. Width:

Reflective Tape at the front and at the rear shall be affixed across the width of the body of the vehicle. This condition will be deemed to be met if the requirement of clause 6.18.2.1.1 or clause 6.18.2.1.2 is met.

 - 6.18.2.1.1 The projected distance between extreme edges of the reflective tape elements, as mounted on the front / rear surface of vehicle shall equate to at least :
 - a) At Front : 65 per cent of the projected width of the Front body surface of the vehicle and
 - b) At Rear: 75 per cent of the projected width of the Rear body surface of the vehicle.
 - 6.18.2.1.2 However, if the manufacturer can prove to the satisfaction of the test agency responsible for type approval that it is impossible to achieve the value referred to in clause 6.18.2.1.1. Above, the cumulative projected width for front or rear

may be reduced to 60 per cent and shall be indicated in the communication document and test report.

6.18.2.2 Length: No special requirement.

6.18.2.3. Height: Not less than 250 mm nor more than 1500 mm above the ground;

6.18.3 Visibility

6.18.3.1. The Reflective Tape shall be considered visible, if at least 70 per cent of the illuminating surface of the installed reflective tape is visible when viewed by an observer positioned at any point within the observation planes defined below:

6.18.3.1.1 For rear and front Reflective Tape the observation plane is perpendicular to the longitudinal axis of the vehicle situated 25 m from the extreme end of the vehicle and bounded by:

a) In height, by two horizontal planes 1 meter and 3 meter above the ground;

b) In width, by two vertical planes which form an angle of 4° outwards from the vehicle's median longitudinal plane and which pass through the intersection of the vertical planes parallel to the vehicle's median longitudinal plane delimiting the vehicle's overall width, and the plane perpendicular to the longitudinal axis of the vehicle that delimits the end of the vehicle.

6.18.4. Orientation

To the rear and to the front:

As close as practicable to being parallel to the transverse plane of the vehicle, compatible with the shape, structure, design and operation requirements of the vehicle, if this is not possible, it shall follow as close as practicable the contour of the outer shape of the vehicle.

6.18.5. Other requirements

Reflective Tape shall be considered continuous if the distance between adjacent elements are as small as possible and shall not exceed 300 mm.

6.19 **Emergency stop signal**

6.19.1 Presence

Optional.

The emergency stop signal shall be given by the simultaneous operation of all the stop or direction indicator lamps fitted as described in clause 6.19.7.

6.19.2 Number

- As specified in clause 6.3.1. or 6.4.1.
- 6.19.3 Arrangement
As specified in clause 6.3.2. or 6.4.2
- 6.19.4 Position
As specified in clause 6.3.3. or 6.4.3.
- 6.19.5 Geometric visibility
As specified in clause 6.3.4. or 6.4.4.
- 6.19.6 Orientation
As specified in clause 6.3.5. or 6.4.5.
- 6.19.7 Electrical connections
- 6.19.7.1 All the lamps of the emergency stop signal shall flash in phase at a frequency of 4.0 ± 1.0 Hz.
- 6.19.7.1.1 However, if any of the lamps of the emergency stop signal to the rear of the vehicle use filament light sources the frequency shall be $4.0 +0.0/-1.0$ Hz.
- 6.19.7.2 The emergency stop signal shall operate independently of other lamps.
- 6.19.7.3 The emergency stop signal shall be activated and deactivated automatically.
- 6.19.7.3.1 The emergency stop signal shall be activated only when the vehicle speed is above 50 km/h and the braking system is providing the emergency braking logic signal defined in IS 14664 : 2010.
- 6.19.7.3.2 The emergency stop signal shall be automatically deactivated if the emergency braking logic signal as defined in IS 14664 : 2010 is no longer provided or if the vehicle-hazard warning signal is activated.
- 6.19.8 Tell-tale
Optional
- 6.19.9 Other requirements
None.
- 6.20 **Exterior courtesy lamp**
- 6.20.1 Presence Optional for motorcycles.

- 6.20.2 Number One or two; however further exterior courtesy lamps to illuminate footrest are permitted. Each footrest shall be illuminated by not more than one lamp.
- 6.20.3 Arrangement No special requirement, however the requirements of clause 6.20.9.3. apply.
- 6.20.4 Position
No special requirement.
- 6.20.5 Geometric visibility
No special requirement.
- 6.20.6 Orientation
No special requirement.
- 6.20.7 Electrical connections
No special requirement.
- 6.20.8 Tell-tale No special requirement.
- 6.20.9 Other requirements
- 6.20.9.1 The exterior courtesy lamp shall not be activated unless the vehicle is stationary and one or more of the following conditions is satisfied:
- (a) The device which starts and/or stops the engine (propulsion system) is set in a position which makes it impossible for the engine (propulsion system) to operate; or
 - (b) A load compartment is opened for access.
- The provisions of clause 5.9. shall be met in all fixed positions of use.
- 6.20.9.2 Approved lamps emitting white light with the exception of main beam headlamps and day time running lamps may be activated as courtesy lamp function. They may also be activated together with the exterior courtesy lamps and the condition of clause 5.10. and 5.11. above may not apply.
- 6.20.9.3 The technical service shall, to the satisfaction of the Testing Agency, perform a visual test to verify that there is no direct visibility of the apparent surface of the exterior courtesy lamps, if viewed by an observer moving on the boundary of a zone on a transverse plane 10 m from the front of the vehicle, a transverse plane 10 m from the rear of the vehicle, and two longitudinal planes 10 m from each side of the vehicle; these four planes to extend from 1 m to 3 m above and perpendicular to the ground as shown in Annex F.

In addition to the conditions described in clause 5.4., the requirements

prescribed above shall be verified in the following vehicle conditions:

Stand: On a prop stand or a centre stand, and both if applicable Steering: Straight ahead, and locked in each available position

At the request of the applicant and with the consent of the Testing Agency this requirement may be verified by a drawing or simulation.

7.0 EXTENSION OF APPROVAL

- 7.1 Every functional modification in technical specifications pertaining to installation of lighting and light-signaling devices declared in accordance with clause 7.2, shall be intimated to the testing agency. Testing agency may then consider, whether,
- 7.1.1 Vehicle with modifications complies with specified requirements, or,
- 7.1.2 any testing is required.
- 7.2 For considering whether testing is required or not, guidelines given in given below shall be followed.
- 7.2.1 In case of following changes, the verification shall be carried out for establishing compliance of the changed parameters to the requirements specified in this standard:
- 7.2.1.1 Number of any of the mandatory lighting and light-signaling devices and any addition to fitment of optional lamps.
- 7.2.1.2 Dimensions prescribed in this standard (or the corresponding clauses of AIS-007 when the amendment to AIS-007 for the incorporating the above becomes effective)
- 7.2.1.3 In case any increase in the dimensions for which a minimum value is specified or any decrease in the dimensions for which a maximum value is specified in this standard, verification on the prototype is not required if the difference between the modified dimension declared by the manufacturer and the requirement specified in this standard is more than 25 mm.
- 7.2.1.4 If there are changes in the contour of the vehicle, which increase the geometric visibility, verification on the prototype is not required.
- 7.2.1.5 While approving fitment of different makes of lighting devices or light-signalling devices, if any of the parameters specified above are affected, verification of compliance to such parameters shall be carried out.
- 7.2.2 Changes other than those listed in clause 7.2.1 are considered to have no adverse effect on the indirect vision
- 7.3 In case of clause 7.1.2., checks for those parameters which are affected by the modifications only need to be carried out.

7.4 In the event of clause 7.1.1. or in the case of clause 7.1.2 after successful compliance to requirements, the certificate of compliance shall be validated for the modified version.

8. to 10. Reserved

11. **TRANSITIONAL PROVISIONS**

11.1 The transitional provisions shall be as per AIS-000, as amended from time to time, unless otherwise stated, except as following

11.2 Daytime Running Lamp shall comply with the requirements specified in AIS 012 (Part 10) (Rev 1) or AIS-198.

12.0 Reserved.

130 AMENDMENTS TO ECE REGULATIONS AFTER THE LEVEL DESCRIBED IN 0.3 OF INTRODUCTION

13.1 **Supplements**

In case of changes in ECE regulation, which are issued as supplements (Supplements do not affect the earlier type approvals) at the request of applicant, approval of compliance to this standard shall be issued taking into account the changes arising out of such supplement(s) to ECE regulation with approval from Chairman AISC.

This shall be incorporated in the test report.

Note: Such changes will be considered for inclusion in this standard at the time of its next amendment /revision.

13.2 **Series of amendments**

Changes in ECE regulation, which are issued as series of amendments (series of amendments may affect the earlier type approvals) will not be considered for issuing approval to this standard.

However, Chairman, AISC may, on a case to case basis, permit to accept latest series of amendments.

This shall be incorporated in the test report.

Note: Such changes will be considered for inclusion in this standard at the time of its next revision

13.3 Acceptance of changes in UN regulations after the level described in 0.3 of introduction shall be as per AIS-000, as amended from time to time, as applicable, unless otherwise stated.

ANNEX A (See 3.1)	
TECHNICAL SPECIFICATION OF VEHICLE TO BE SUBMITTED AT THE TIME OF TYPE APPROVAL	
A-1	The specification submitted by manufacturer (applicant) at the time of applying for the type approval of the vehicle to this standard shall contain at least the information set out in the following entries of Table 1, Table 1B & Table 1C of AIS-007 (Revision 5) as applicable.
	Table 1C for L2 Category : 0.2, 0.3, 0.3.1, 0.4, 0.4.1, 0.4.2, 1.2, 2.0, 2.1.1, 2.1.1.1, 2.1.2.1, 3.1.1, 3.2, 3.2.1.5, 6.5.1, 6.5.2, 6.5.3, 6.5.4, 6.5.5, 6.5.5.1, 6.5.5.2, 6.5.5.3, 6.5.5.4, 6.5.6, 6.5.6.1, 6.5.6.2, 6.5.6.3, 6.9.1.4, 6.9.1.5.
	Table 1 (for L1, & L5 category): 0.2., 0.4., 0.5., 0.5.1, 0.5.2, 1.2, 2, 2.1, 2.1.1, 2.3.1, 3, 3.2.1.3, 5.2., 5.2.1, 5.2.2., 8.0, 8.1, 8.2, 8.3, 8.4, 8.5
	Table 1B (for E-rickshaw/ E-cart vehicles) : 0.2, 0.3, 0.4, 0.4.1, 0.4.2, 1.2, 2.0, 2.1, 2.1.1, 2.3.1, 4.2, 4.2.1, 4.2.2, 7.0, 7.1, 7.2, 7.3, 7.4, 7.5

**ANNEX B
(Reserved)**

ANNEX C (See 2.7)

LAMP SURFACES, AXIS AND CENTRE OF REFERENCE, AND ANGLES OF GEOMETRIC VISIBILITY

A-1

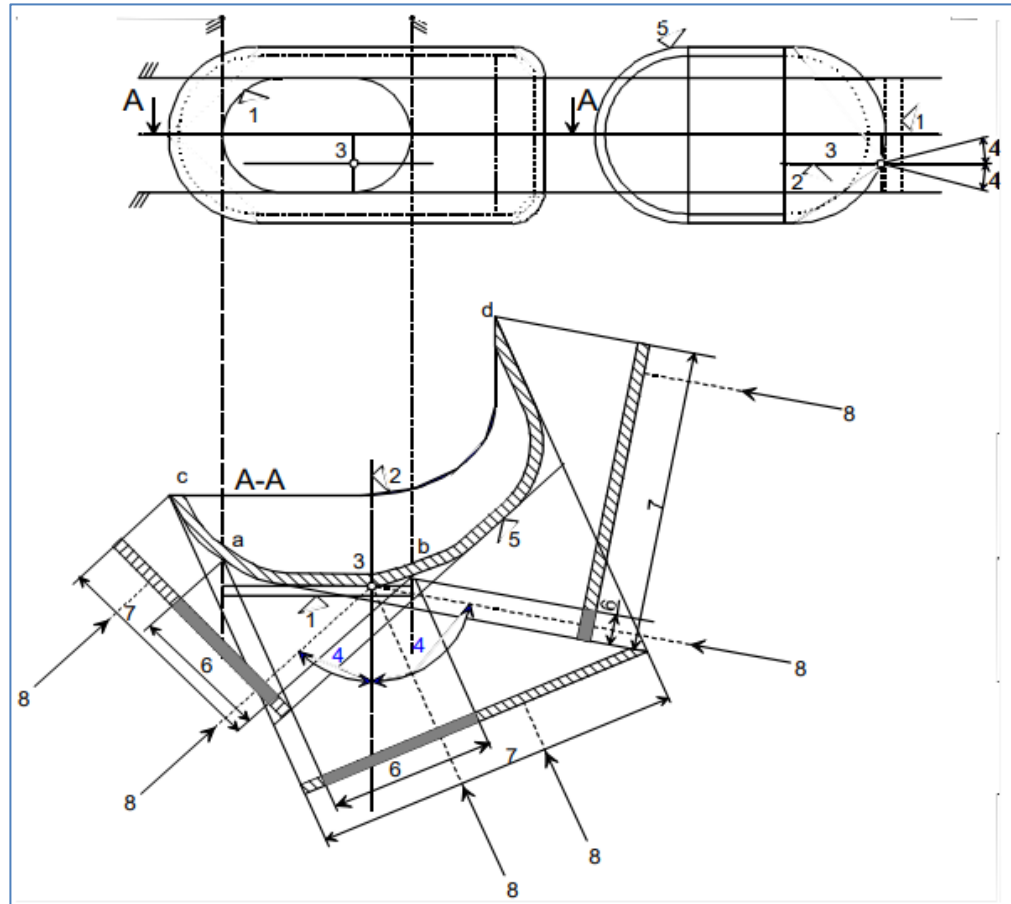

KEY

1. Illuminating surface
2. Axis of reference
3. Centre of reference
4. Angle of geometric visibility
5. Light-emitting surface
6. Apparent surface based on illuminating surface
7. Apparent surface based on light-emitting surface
8. Direction of visibility

Note: Notwithstanding the drawing, the apparent surface is to be considered as tangent to the light-emitting surface.

ILLUMINATING SURFACE IN COMPARISON WITH LIGHT-EMITTING SURFACE
 (See 2.8. and 2.9. of this standard)

	illuminating surface	Light-emitting surface
Edges are	a and b	c and d

SKETCH A

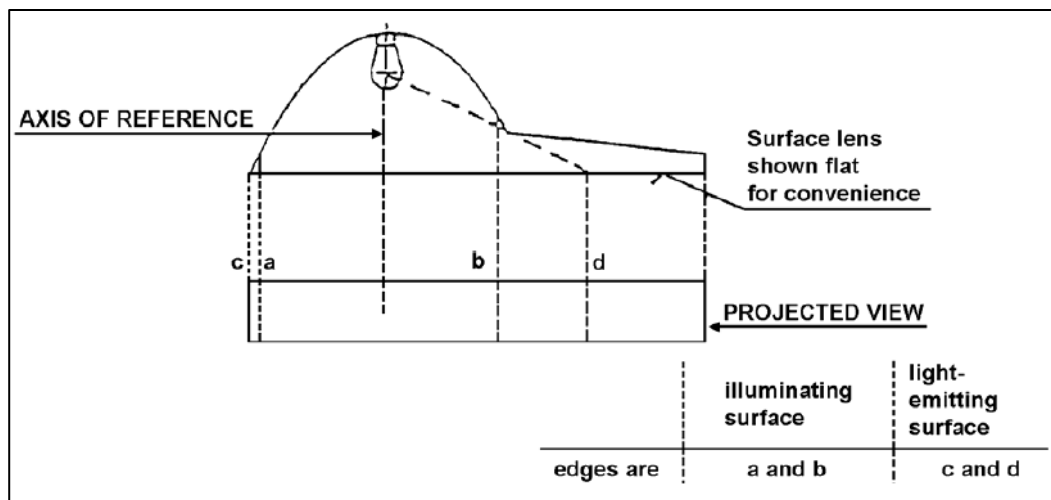

SKETCH B

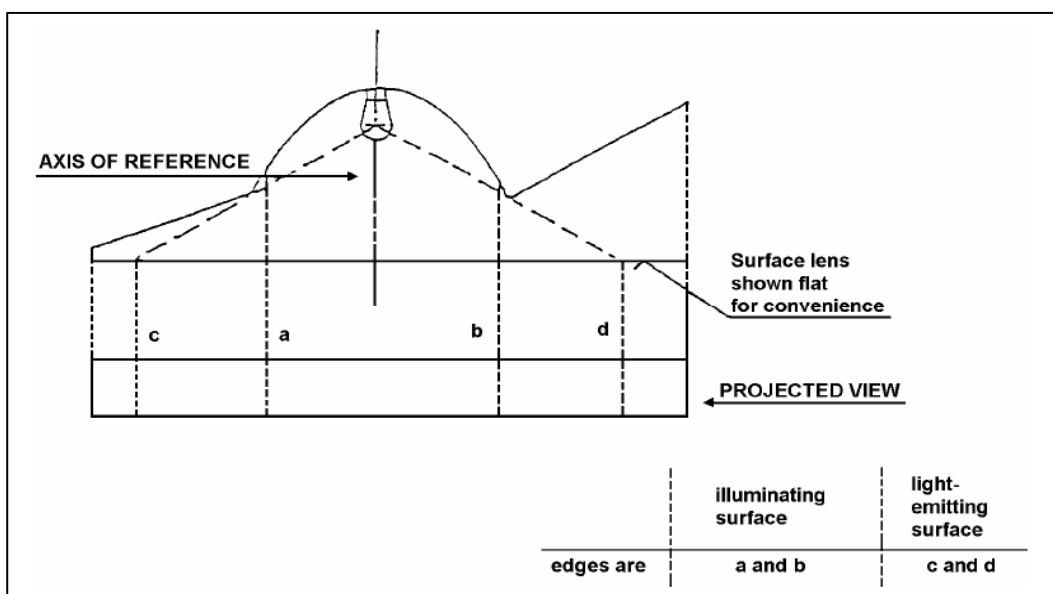

ANNEX D
 (See 5.9.)
FORWARD VISIBILITY OF RED LIGHTS AND REARWARD VISIBILITY OF WHITE LIGHTS

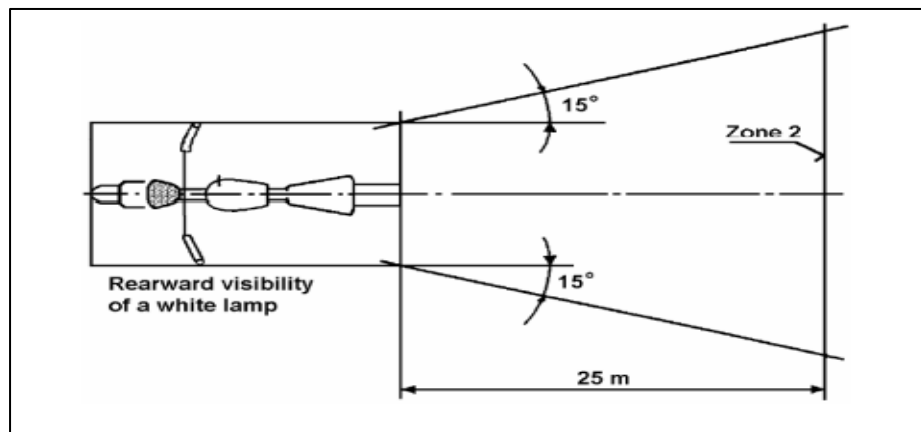
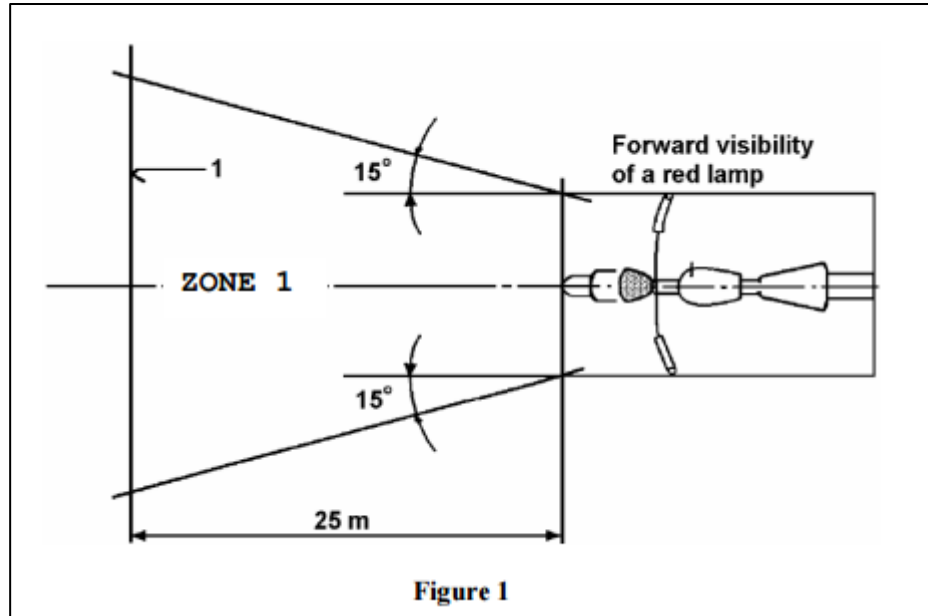

As regard to height, Zone 1 and Zone 2, as seen by observer is limited within two horizontal planes which are 1 meter and 2.2 meter respectively above the ground.

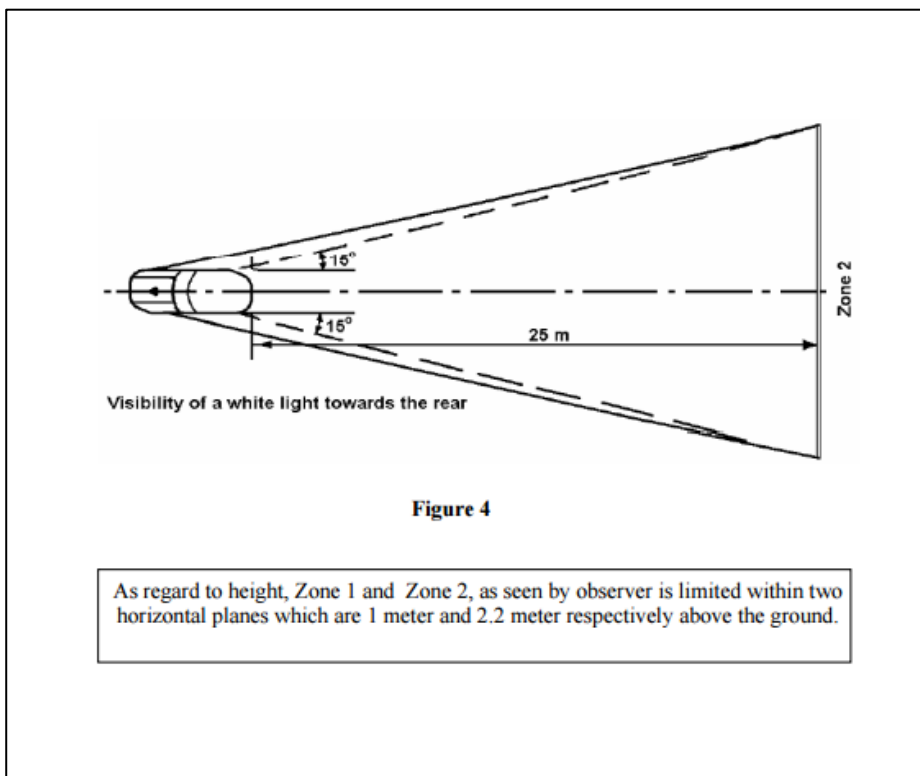
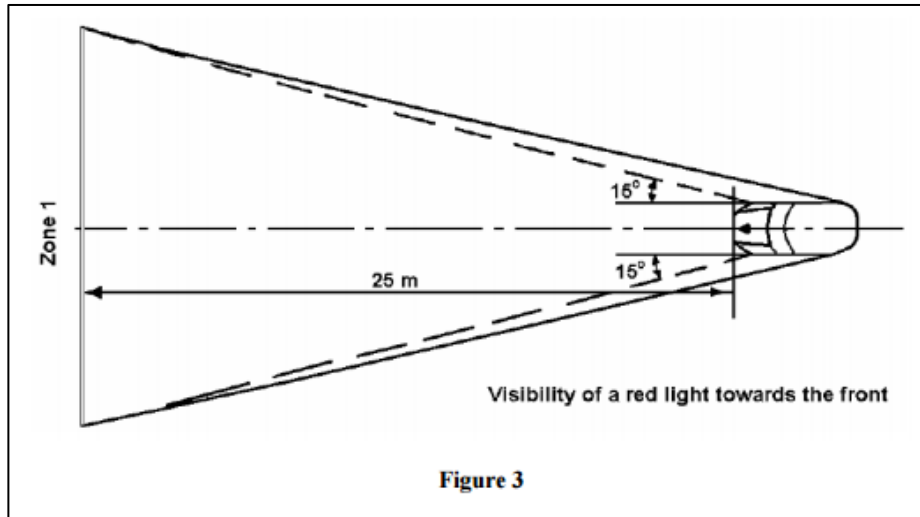

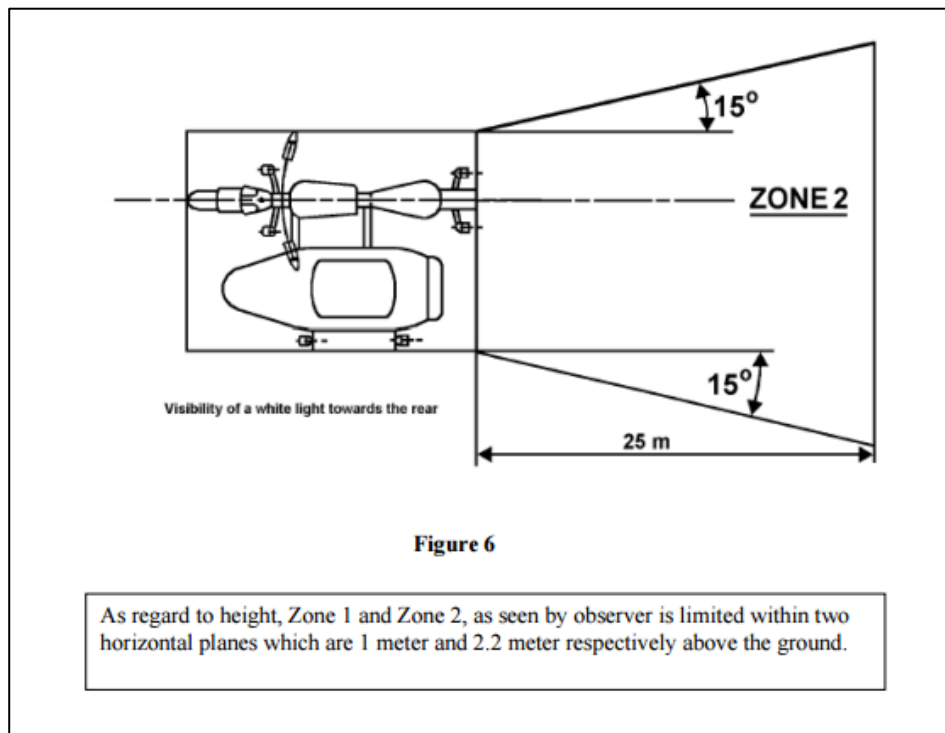
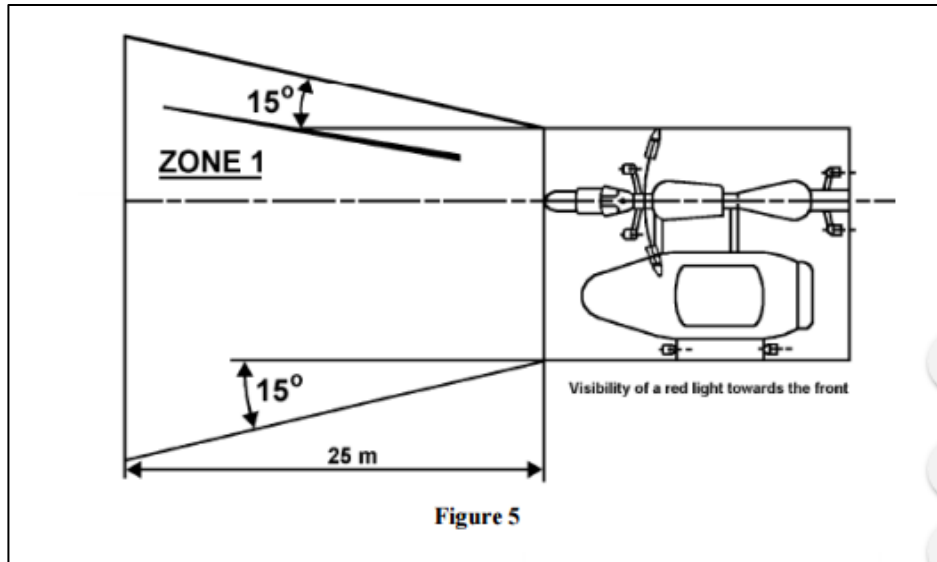

ANNEX F

OBSERVING AREA TOWARDS THE APPARENT SURFACE OF EXTERIOR COURTESY LAMPS

Zones of observation

This drawing shows the zone from one side, the other zones are from the front, the rear and from the other side of the vehicle.

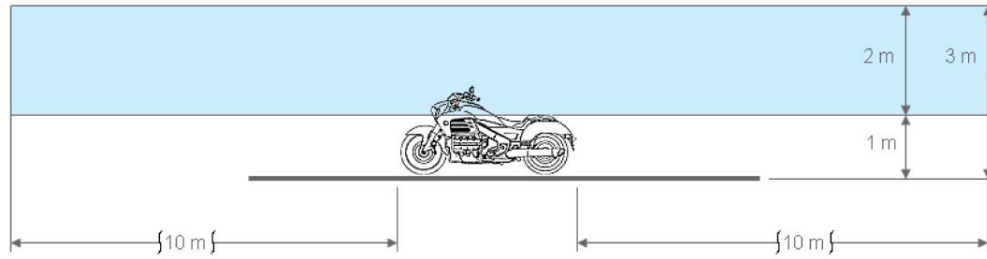

Boundaries of the zones

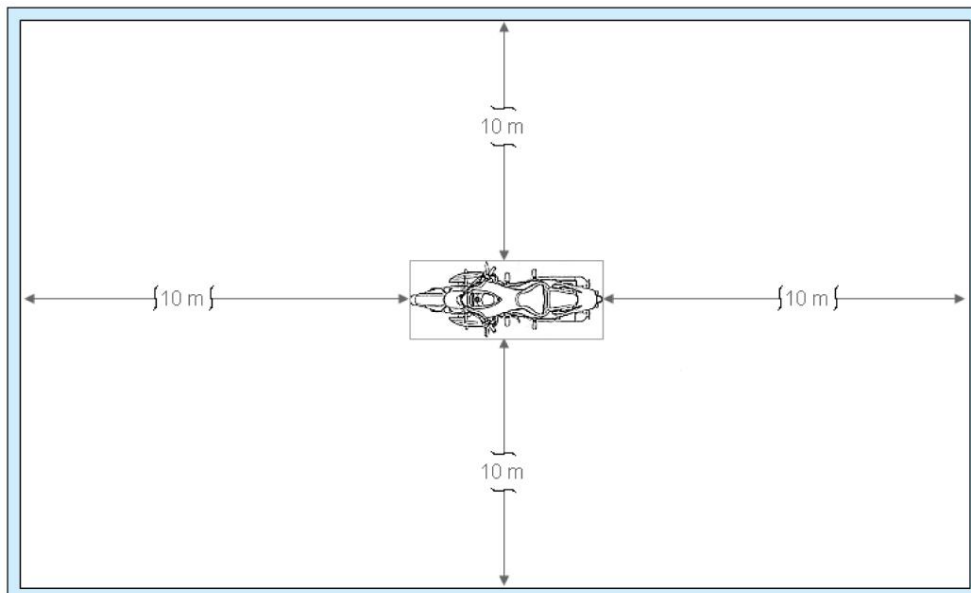

ANNEX G
(See introduction)

**COMPOSITION OF AISC PANEL ON
LIGHTING AND LIGHT SIGNALLING DEVICES***

Convener	
Mr. Feroz Ali Khan	SIAM (Hero MotoCorp Ltd.)
Members	Representing
Mr. B.V. Shamsundara	ARAI
Mrs. Jyoti Kirve	ARAI
Mr. Kamalesh Patil	ARAI
Dr. Madhusudan Joshi	ICAT
Representative From	CFMTTI
Mr. Arvind Kumbhar	SIAM (Bajaj Auto Ltd.)
Mr. Abhay Kumar	SIAM (Bajaj Auto Ltd.)
Mr. Varun Sharma	SIAM (Hero MotoCorp Ltd.)
Mr. M S Anand Kumar	SIAM (TVS Motors)
Mr. Mohit Kansal	SIAM (India Yamaha)
Mrs. Pushpanjali Pathak	SIAM (Mahindra & Mahindra)
Mr. Venusuresh	SIAM (Royal Enfield)
Mr. Vipin Sharma	SIAM (Honda Motorcycle & Scooter India)
Mr. Arpan Shukla	SIAM (Honda Motorcycle & Scooter India)
Mr. Uday Harite	ACMA

ANNEX H
(See introduction)

COMMITTEE COMPOSITION *
Automotive Industry Standards Committee

Chairperson	
Dr. Reji Mathai	Director, The Automotive Research Association of India
Members	Representing
Representative from	Ministry of Road Transport and Highways
Representative from	Ministry of Heavy Industries
Representative from	Office of the Development Commissioner, MSME, Ministry of Micro, Small and Medium Enterprises
Shri Shrikant R. Marathe	Former Chairman, AISC
Head-TED	Bureau of Indian Standards
Director	Central Institute of Road Transport
Director	Global Automotive Research Centre
Director	International Centre for Automotive Technology
Director	Indian Institute of Petroleum
Director	National Automotive Test Tracks
Director	Vehicles Research and Development Establishment
Director	Indian Rubber Manufacturers Research Association
Representatives from	Society of Indian Automobile Manufacturers
Representatives from	Tractor and Mechanization Association
Representatives from	Automotive Components Manufacturers Association of India
Representative from	Indian Construction Equipment Manufacturers' Association
Member Secretary	
Shri Vikram Tandon	The Automotive Research Association of India