

AMENDMENT NO. 1 (05/2024)

To

**AIS-002 (Part 1) (Rev.2):2023 Automotive Vehicles - Approval of Devices for Indirect Vision
intended for use on L category with bodywork vehicles, M and N category -
Installation Requirements**

1. Page 4/65, clause 15.2.1.1.3

Substitute following text for the existing text in Table

Main rear-view Classes III or VII:

Second Para of footnote 1 in table shall be corrected as below.

Where a single class III or VII rear-view mirror is fitted this shall be located on the right-hand side of the vehicle.

2. Page 9/65, clause 15.2.2.4

Substitute following text for the existing text:

“15.2.2.4 The prescribed Classes II, III, IV and VII mirror or monitor on the driver’s side of the vehicle shall be so located that an angle of not more than 55° is formed between the vertical longitudinal median plane of the vehicle and the vertical plane passing through the centre of the mirror or monitor and through the centre of the straight line 65 mm long which joins the driver's two ocular points. This condition shall be met if the manufacturer certifies so for the vehicles which are already approved as per AIS-002(Part 1) (Rev. 1) and there is no change in any parameter affecting the above-mentioned requirement. For new installation requirement, verification may be carried out based on agreement between the testing agency and manufacturer/applicant.

3. Page 25/65, clause 22.4

Substitute following text for the existing text:

22.4 Extension of Approvals for engineering and administrative changes:

22.4.1 In the case of 22.1, extensions shall be granted subject to the conditions of AIS-002 (Part 1) (Rev. 2): 2023. Such extensions shall be deemed to be compliance to AIS-002 (Part 1) (Rev.1):2011.

22.4.2 In the case of 22.2, extensions shall be granted subject to conditions of AIS- 002 (Part 1) (Rev.1):2011 till the notified date of implementation of AIS-002 (Part 1) (Rev.2): 2023.

PRINTED BY
THE AUTOMOTIVE RESEARCH ASSOCIATION OF INDIA
P. B. NO. 832, PUNE 411 004

ON BEHALF OF
AUTOMOTIVE INDUSTRY STANDARDS COMMITTEE

UNDER
CENTRAL MOTOR VEHICLES RULES - TECHNICAL STANDING COMMITTEE

SET-UP BY
MINISTRY OF ROAD TRANSPORT & HIGHWAYS
(DEPARTMENT OF ROAD TRANSPORT & HIGHWAYS)
GOVERNMENT OF INDIA

29th May 2024

AUTOMOTIVE INDUSTRY STANDARD

**Automotive Vehicles – Approval of
Devices for Indirect Vision intended
for use on L category with bodywork
vehicles, M and N category -
Installation requirements
(Revision 2)**

PRINTED BY
THE AUTOMOTIVE RESEARCH ASSOCIATION OF INDIA
P.B. NO. 832, PUNE 411 004

ON BEHALF OF
AUTOMOTIVE INDUSTRY STANDARDS COMMITTEE

UNDER
CENTRAL MOTOR VEHICLE RULES – TECHNICAL STANDING COMMITTEE

SET-UP BY
MINISTRY OF ROAD TRANSPORT & HIGHWAYS
(DEPARTMENT OF ROAD TRANSPORT & HIGHWAYS)
GOVERNMENT OF INDIA

May 2023

INTRODUCTION

0.0 The Government of India felt the need for a permanent agency to expedite the publication of standards and development of test facilities in parallel when the work on the preparation of the standards is going on, as the development of improved safety critical parts can be undertaken only after the publication of the standard and commissioning of test facilities. To this end, the erstwhile Ministry of Surface Transport (MOST) has constituted a permanent Automotive Industry Standards Committee (AISC) vide order No.RT-11028/11/97-MVL dated September 15, 1997. The standards prepared by AISC will be approved by the permanent CMVR Technical Standing Committee (CTSC). After approval, the Automotive Research Association of India, (ARAI), Pune, being the Secretariat of the AIS Committee, has published this standard. For better dissemination of this information ARAI may publish this document on their Web site.

0.1 Accordingly, AIS-002 covering mandatory requirements regarding installation of rear-view mirrors was published in 2001 and implemented thereafter in 2003.

0.2 With technological developments in the rear-view mirrors and devices for Indirect Vision, AIS-002 was taken up for revision is prepared in two parts.

This part covers the requirements for installation of rear-view mirrors and devices for indirect vision for L category vehicles with bodywork, M and N category of vehicles.

0.3 This part is based on the following UN regulation:

UN R 46 Revision 6, Amendment 7 Supplement 9 to the 04 series of amendments Date of entry into force: 30 September 2021	Uniform provisions concerning the approval of devices for indirect vision and of motor vehicles with regard to the installation of these devices
--	--

0.4 While preparing this standard attempt has been made to align with the above UN regulation. However, certain changes were necessary in the Indian context.

0.5 The following standards contain provisions, which through reference in this text constitute provisions of the standard

AIS-001 (Part 1) (Rev. 2)	Automotive Vehicles - Approval of Devices for Indirect Vision intended for use on M, N category and L category with bodywork vehicles - specification
AIS-007	Information on Technical Specifications to be Submitted by the Vehicle Manufacturer

IS 14272: 2011	Automotive Vehicles – Types - Terminology
IS 2553 (Part 2) (Revision 1): 2019.	Safety glass - Specification - Part 2 for Road Transport
AIS-097: 2007	Procedure for Determining the "H" Point and the Torso Angle for 50th Percentile Adult Male in Seating Positions of Motor Vehicles
ISO 4130-1978	Road vehicles - Three-dimensional reference system and fiducial marks - Definitions
ISO 612-1978	Road vehicles - Dimension of motor vehicles and towed vehicles - Terms and definitions.

- 0.6 The composition of AIS panel and AIS Committee responsible for preparation of this standard is given in Annex P and Annex Q respectively.

**Automotive Vehicles – Approval of Devices for Indirect
Vision intended for use on L category with bodywork
vehicles, M and N category - Installation requirements**

Para. No.	Contents	Page No.
1.	Scope	1/65
2. to 11.	Reserved	1/65
12.	Definitions	1/65
13.	Application for approval	2/65
14.	Approval	3/65
15.	Requirements	3/65
16.	Requirement for Devices for indirect vision other than mirrors	19/65
17.	Modifications of the vehicle type and extension of type approval	24/65
18.	Conformity of production	25/65
19. to 21.	Reserved	25/65
22.	Transitional provisions	25/65
23.	Amendments to UN regulations after the level described in 0.3 of introduction	26/65
List of Annexes:		
Annex A	Reserved	27/65
Annex B	Information to be submitted at the time of type approval	28/65
Annex C to G	Reserved	30/65
Annex H	Procedure for determining the "H" point and the actual torso angle for seating positions in motor vehicles	31/65
Annex HA	Description of the three dimensional "H" point machine	37/65
Annex HB	Three - dimensional reference system	40/65
Annex HC	Reference data concerning seating positions	41/65
Annex J	Reserved	42/65
Annex K	Calculation of the detection distance for CMS of Class V and VI	43/65
Annex L	Determination of the displayed object size for CMS of Class V & VI	47/65
Annex M	Test methods and safety provisions for CMS of Classes I to IV	50/65
Annex N	Criteria for extension of approval	61/65
Annex P	Composition of AISC panel on rear view mirrors	63/65
Annex Q	Committee composition Automotive Industry Standards Committee	65/65

**Automotive Vehicles – Approval of Devices for Indirect Vision
intended for use on L category with bodywork vehicles,
M and N category - Installation requirements**

1. SCOPE

- 1.1 This standard applies to compulsory and optional devices for indirect vision set out in the table under clause 15.2.1.1.1. of this standard for vehicles of category M and N and to compulsory and optional devices for indirect vision mentioned in clauses 15.2.1.1.3 and 15.2.1.1.4 of this standard for vehicles of category L with bodywork at least partly enclosing the driver.
- 1.2 This standard does not apply to devices other than those prescribed under clause 1.1 and their installation, for observing the vision area(s) immediately adjacent to the front and/or the passenger's side of vehicles of category M1, M2, M3, N1 and N2 ≤ 7.5 t.

2. to 11. Reserved

12. DEFINITIONS

For the purpose of this standard:

- 12.1. **"The driver's ocular points"** means two points 65 mm apart and 635 mm vertically above point R of the driver's seat as defined in Annex H. The straight line joining these points runs perpendicular to the vertical longitudinal median plane of the vehicle. The centre of the segment joining the two ocular points is in a vertical longitudinal plane which shall pass through the centre of the driver's designated seating position, as specified by the vehicle manufacturer.

Note: The R point declared by the manufacturer may be used for measurement of field of visions

- 12.2. **"Ambinocular vision"** means the total field of vision obtained by the superimposition of the monocular fields of the right eye and the left eye (see Figure 3 below).

Note : Figures 1 and 2 reserved.

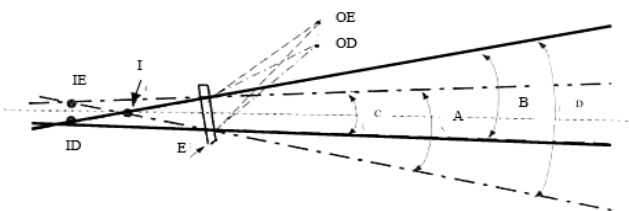

Figure 3
(See 12.2)
Ambinocular vision

E= interior rear-view mirror
 OD = driver's eyes
 OE = driver's eyes
 ID = virtual monocular images
 IE = virtual monocular images
 I = virtual ambinocular images
 A = angle of vision of right eye.
 B = angle of vision of left eye.
 C = binocular angle of vision.
 D = angle of Ambinocular vision.

12.3. **"Type of vehicle as regards indirect vision"** means motor vehicles which are identical in respect of the following basic features:

12.3.1. Type of device for indirect vision;

12.3.2. The bodywork features which reduce the field of vision

12.3.3. The coordinates of point R (where applicable);

12.3.4 The prescribed positions, and type-approval markings of compulsory and (if fitted) optional devices for indirect vision.

12.4 Reserved

12.5 **"Forward control"** means a configuration in which more than half of the engine length is rearward of the foremost point of the windshield base and the steering wheel hub in the forward quarter of the vehicle length.

12.6 **"Ocular reference point"** means the middle point between the driver's ocular points.

12.7 **"Unladen (kerb) mass"** (kg) means the mass of the vehicle in running order, unoccupied and unladen but with the addition of 75 kg for the mass of the driver, the mass of fuel, in the case of liquid fuels, corresponding to 90 per cent of the capacity of the fuel tank specified by the manufacturer, and in the case of gaseous fuels such as CNG, LPG etc. the legally permitted maximum, and the masses of coolant, lubricant, tools and spare wheel, if any.

13. APPLICATION FOR APPROVAL

13.1. Information to be submitted at the time of applying for type approval of the devices for indirect vision shall be as given in Annex B

13.2. Reserved.

13.3. A vehicle representative of the vehicle type to be approved shall be submitted to the testing agency responsible for conducting the approval tests.

13.4. Reserved

- 13.5. The CMS shall be provided by the applicant with the following documents:
- (a) Technical specification of the CMS;
 - (b) Operator's manual
 - (c) Documentation referred to in Annex M, clause 2.3.
 - (d) Documentation referred to in clause 16.1.1.1.1., if applicable

14. APPROVAL

- 14.1. If the vehicle type submitted for approval in accordance with clause 13 above, meets the requirements of clause 15 of this standard, approval shall be granted.
- 14.2. Reserved
- 14.3. Reserved

15. REQUIREMENTS

15.1 General

- 15.1.1 The compulsory and optional devices for indirect vision, set out in the table under clause 15.2.1.1.1, below installed on the vehicle shall be classes described in AIS-001 (Part 1) (Rev. 2).
- 15.1.2. Devices for indirect vision shall be fitted in such a way that the device does not move so as significantly to change the field of vision as measured or vibrate to an extent which would cause the driver to misinterpret the nature of the image perceived.
- 15.1.3. The conditions laid down in 15.1.2 shall be maintained when the vehicle is moving at speeds of up to 80 per cent of its maximum design speed, but not exceeding 150 km/h.
- 15.1.4. The fields of vision defined below shall be established using ambinocular vision, the eyes being at the "driver's ocular points" as defined in 12.1. above The fields of vision shall be determined when the vehicle is in the Unladen kerb mass condition as defined in 12.7, plus for M1 and N1 vehicles one front seat passenger (75 kg). When established through windows the glazing shall have a total light transmission factor in accordance with IS 2553 (Part 2): (Revision 1) 2019.

15.2. Devices for indirect vision

- 15.2.1. Number
- 15.2.1.1. Minimum number of compulsory devices for indirect vision

15.2.1.1.1. The fields of vision prescribed in clause 15.2.4 shall be obtained from the minimum number of mandatory mirrors or camera-monitor devices set out in the following table.

A minimum number of camera-monitor systems is undefined, but they shall provide the same field of vision as given in the table below and the provision on the minimum mounting height does not apply.

In the case of camera-monitor systems, the maximum number of monitors shall not exceed the corresponding number of mirrors.

15.2.1.1.2 In the case a camera-monitor system is used for rendering (the) field(s) of vision, the relevant field(s) of vision shall be permanently visible to the driver when the ignition is on or the vehicle master control switch is activated (whichever is applicable) and not used for other information. However, when the vehicle is moving forward at a speed above 10 km/h or backwards, the monitor or the part of the monitor intended for rendering the Class VI field of vision may be used for other information. Multiple images may be used or displayed provided that the monitor has been approved in this mode.

15.2.1.1.3 Rear-view mirrors required for L-category vehicles with body work

Category of vehicle	Rear-view Class I	Main rear-view Classes III and VII
L category motor vehicles fitted with bodywork which partly or wholly encloses the driver	1 ¹	1, if there is a Class I rear-view mirror; 2, if there is not a Class I rear-view mirror

¹ No rear-view mirror Class I is required if the visibility conditions referred to in paragraph 15.2.5.4.1. below cannot be met. In this case two Class III or VII rear-view mirrors are required, one giving the view on the left and one giving the view on the right-hand side of the vehicle.

Where a single class III or VII rear-view mirror is fitted this shall be located on the left-hand side of the vehicle.

It is recommended that articulation adjustment for CMS may be limited only to such positions at which it meets the provisions of Field of Vision mentioned in this standard

Vehicle category	Rear-view Class I	Main rear-view Class II	Main rear-view Class III	Wide-angle view Class IV	Close-proximity view Class V	Front view Class VI
M ₁	Compulsory Unless the vehicle is fitted with anything other than safety glazing material in the field of vision prescribed in paragraph 15.2.4.1. See 15.2.2.10	Optional	Compulsory 1 on the driver's side and 1 on the passenger's side. Class II mirrors may be fitted as an alternative.	Optional 1 on the driver's side and / or 1 on the passenger's side	Optional 1 on the driver's side and 1 on the passenger's side (both shall be fitted at least 2 m above the ground)	Optional (shall be fitted at least 2 m above the ground)
M ₂	Optional (no requirements for the field of view)	Compulsory 1 on the driver's side and 1 on the passenger's side See 15.2.2.11	See 15.2.2.11	Optional 1 on the driver's side and / or 1 on the passenger's side	Optional 1 on the driver's side and 1 on the passenger's side (both shall be fitted at least 2 m above the ground)	Optional (shall be fitted at least 2 m above the ground)
M ₃	Optional (no requirements for the field of view)	Compulsory 1 on the driver's side and 1 on the passenger's side	Not permitted	Optional 1 on the driver's side and / or 1 on the passenger's side	Optional 1 on the driver's side and 1 on the passenger's side (both shall be fitted at least 2 m above the ground)	Mandatory (shall be fitted at least 2 m above the ground) See 15.2.2.7 and 15.2.2.12
N ₁	Compulsory Unless the vehicle is fitted with anything other than safety glazing material in the field of vision prescribed in paragraph 15.2.4.1. See 15.2.2.10	Optional	Compulsory 1 on the driver's side and 1 on the passenger's side. Class II mirrors may be fitted as an alternative.	Optional 1 on the driver's side and / or 1 on the passenger's side	Optional 1 on the driver's side and 1 on the passenger's side (both shall be fitted at least 2 m above the ground)	Optional (shall be fitted at least 2 m above the ground)

Vehicle category	Rear-view Class I	Main rear-view Class II	Main rear-view Class III	Wide-angle view Class IV	Close-proximity view Class V	Front view Class VI
<p>N₂ ≤ 7.5 t</p>	<p>Optional (no requirements for the field of view)</p>	<p>Compulsory 1 on the driver's side and 1 on the passenger's side</p>	<p>Not permitted</p>	<p>Compulsory For both sides if a Class V mirror can be fitted.</p> <p>Optional 1 on the driver's side and 1 on the passenger's side</p> <p>In addition, according to paragraphs 15.2.4.5.6 to 15.2.4.5.11 for vehicles with a mounting height of the Class V mirror of not less than 2.4 m (see paragraph 15.2.4.5.12): the required field of vision (paragraphs 15.2.4.5.6 to 15.2.4.5.9) may be viewed using a combination of direct view and indirect vision devices (of Classes IV, V, VI).</p>	<p>Compulsory see paragraph 15.2.2.7. and 15.2.4.5.5. 1 on the passenger's side.</p> <p>Optional 1 on driver's side (both shall be fitted at least 2 m above the ground)</p> <p>A tolerance of +10 cm may be applied.</p> <p>In addition, according to paragraphs 15.2.4.5.6 to 15.2.4.5.11 for vehicles with amounting height of the Class V mirror of not less than 2.4 m (see paragraph 15.2.4.5.12): the required field of vision (paragraphs 15.2.4.5.6 to 15.2.4.5.9) maybe viewed using a combination of direct view and indirect vision devices (of Classes IV, V, VI).</p>	<p>Optional 1 front mirror (shall be fitted at least 2 m above the ground)</p> <p>In addition, according to paragraphs 15.2.4.5.6 to 15.2.4.5.11 for vehicles with amounting height of the Class V mirror of not less than 2.4m (see paragraph 15.2.4.5.12): the required field of vision (paragraphs 15.2.4.5.6 to 15.2.4.5.9) may be viewed using a combination of direct view and indirect vision devices (of Classes IV, V, VI).</p>

Vehicle category	Rear-view Class I	Main rear-view Class II	Main rear-view Class III	Wide-angle view Class IV	Close-proximity view Class V	Front view Class VI
N ₂ > 7.5 t	Optional (no requirements for the field of view)	Compulsory 1 on the driver's side and 1 on the passenger's side	Not permitted	Compulsory 1 on the driver's side and 1 on the passenger's side In addition, according to paragraphs 15.2.4.5.6 to 15.2.4.5.11 for vehicles with amounting height of the Class V mirror of not less than 2.4 m (see paragraph 15.2.4.5.12): the required field of vision (paragraphs 15.2.4.5.6 to 15.2.4.5.9) may be viewed using a combination of direct view and indirect vision devices (of Classes IV, V, VI).	Compulsory, see paragraph 15.2.2.7. and 15.2.4.5.5. 1 on the passenger's side Optional 1 on driver's side (both shall be fitted at least 2 m above the ground) In addition, according to paragraphs 15.2.4.5.6 to 15.2.4.5.11 for vehicles with amounting height of the Class V mirror of not less than 2.4 m (see paragraph 15.2.4.5.12): the required field of vision (paragraphs 15.2.4.5.6 to 15.2.4.5.9) may be viewed using a combination of direct view and indirect vision devices (of Classes IV, V, VI).	Compulsory, see paragraph 15.2.1.1.2. 1 front mirror (shall be fitted at least 2 m above the ground) See 15.2.2.7 and 15.2.2.12 In addition, according to paragraph s15.2.4.5.6 to 15.2.4.5.11 for vehicles with amounting height of the Class V mirror of not less than 2.4m (see paragraph 15.2.4.5.12): the required field of vision (paragraphs 15.2.4.5.6 to 15.2.4.5.9) may be viewed using a combination of direct view and indirect vision devices (of Classes IV, V, VI).

Vehicle category	Rear-view Class I	Main rear-view Class II	Main rear-view Class III	Wide-angle view Class IV	Close-proximity view Class V	Front view Class VI
N ₃	Optional (no requirements for the field of view)	Compulsory 1 on the driver's side and 1 on the passenger's side	Not permitted	Compulsory 1 on the driver's side and 1 on the passenger's side In addition, according to paragraphs 15.2.4.5.6. to 15.2.4.5.11 for vehicles with amounting height of the Class V mirror of not less than 2.4 m (see paragraph 15.2.4.5.12.): the required field of vision (paragraphs 15.2.4.5.6. to 15.2.4.5.9.) may be viewed using a combination of direct view and indirect vision devices (of Classes IV, V, VI).	Compulsory, see paragraph 15.2.2.7. and 15.2.4.5.5.1 on the passenger's side Optional 1 on driver's side (both shall be fitted at least 2 m above the ground) In addition, according to paragraphs 15.2.4.5.6 to 15.2.4.5.11 for vehicles with amounting height of the Class V mirror of not less than 2.4 m (see paragraph 15.2.4.5.12.): the required field of vision (paragraphs 15.2.4.5.6. to 15.2.4.5.9.) maybe viewed using a combination of direct view and indirect vision devices (of Classes IV, V, VI).	Compulsory, see paragraph 15.2.1.1.2. 1 front mirror (shall be fitted at least 2 m above the ground) See 15.2.2.7 and 15.2.2.12 In addition, according to paragraphs 15.2.4.5.6. to 15.2.4.5.11. for vehicles with amounting height of the Class V mirror of not less than 2.4m (see paragraph 15.2.4.5.12.): the required field of vision (paragraphs 15.2.4.5.6. to 15.2.4.5.9) may be viewed using a combination of direct view and indirect vision devices (of Classes IV, V, VI).

Note: “Passenger’s” side means the side opposite to where the driver seat is provided.

- 15.2.1.1.4 **Optional rear-view mirrors for L-category vehicles with body work**
 The fitting of a Class III or VII rear-view mirror on the side of the vehicle opposite to that of the mandatory rear-view mirror referred to in clause 15.2.1.1.3. above, is permissible. The rear-view mirror shall meet the requirements of this standard
- 15.2.1.2. The provisions of this standard do not apply to the surveillance mirrors defined in clause 2.1.1.3 of AIS-001 (Part 1) (Rev. 2). Nevertheless, the exterior surveillance mirrors shall be mounted at least 2 m above the ground when the vehicle is under a load corresponding to its maximum technical permissible mass or shall be fully integrated in a housing including Class II or III mirror(s) which is (are) type approved to this standard.
- 15.2.2. **Position**
- 15.2.2.1. Devices for indirect vision shall be so placed that the driver, when sitting on the driving seat in a normal driving position, has a clear view of the road to the rear, side(s) or front of the vehicle.
- 15.2.2.2. Classes II to VII mirrors shall be visible through the side windows or through the portion of the windscreen that is swept by the windscreen wiper. Nevertheless, for design reasons, this last provision (i.e. the provisions relating the cleaned part of the windscreen) shall not apply to:
- (a) Classes II to VII mirrors on the passenger side and optional exterior mirrors on the driver side of vehicles of categories M₂ and M₃;
 - (b) Class VI front-view mirrors
- 15.2.2.3. In the case of any vehicle, which is in chassis/cab form when the field of vision is measured, the minimum and maximum body widths shall be stated by the manufacturer and, if necessary, simulated by dummy headboards. All vehicles and devices for indirect vision configurations taken into consideration during the tests shall be shown in the test report for a vehicle with regard to the installation of devices for indirect vision.
- 15.2.2.4. The prescribed Classes II, III, IV and VII mirror or monitor on the driver's side of the vehicle shall be so located that an angle of not more than 55° is formed between the vertical longitudinal median plane of the vehicle and the vertical plane passing through the centre of the mirror or monitor and through the centre of the straight line 65 mm long which joins the driver's two ocular points.
- 15.2.2.5. Devices for indirect vision shall not project beyond the external bodywork of the vehicle substantially more than is necessary to comply with the requirements concerning fields of vision laid down in clause 15.2.4. below.
- 15.2.2.6. Where the lower edge of a Classes II to VII mirror is less than 2 m above the ground when the vehicle is loaded to its technically permissible maximum laden mass, this mirror shall not project more than 250 mm beyond the overall width of the vehicle measured without mirrors.

- 15.2.2.7 Class V and Class VI mirrors shall be mounted on vehicles in such a way that, regardless of their position after adjustment, no part of these mirrors or their holders is less than 2 m from the ground when the vehicle is under a load corresponding to its prescribed GVW declared by vehicle manufacturer.

These mirrors shall not, however, be mounted on vehicles the cab height of which is such as to prevent compliance with this requirement. In this case another device for indirect vision is not mandatory.

Note : In the following cases, fitment of rear view mirror meeting the conditions of clause 15.2.2.7 is considered not possible:

Whether the requirement of parts of rear-view mirror cannot be fitted above 2m from the ground, to achieve a field of vision, shall be verified as follows:

Vehicles with the ocular point of the driver \leq 2m from the ground under prescribed GVW declared by vehicle manufacturer.

In other cases, manufacturer demonstrates the condition in an appropriate layout sketch.

- 15.2.2.8. Subject to the requirements of 15.2.2.5, 15.2.2.6 and 15.2.2.7, devices for indirect vision may project beyond the permissible maximum widths of vehicles.
- 15.2.2.9. All Class VII mirrors shall be attached in such a way that they remain in a stable position under normal vehicle driving conditions.
- 15.2.2.10 If the vehicle is fitted with anything other than safety glazing material in the field of vision prescribed in clause 15.2.4.1, fitment of rear-view device Class I for categories of M1 and N1 is optional. In such cases, the field of vision requirements need not be complied with.
- 15.2.2.11 Class III Main rear-view device are permitted in the place of Class II Main rear-view device. In such cases, field of vision prescribed for Class III device shall be complied with.
- 15.2.2.12 Fitment of Class VI device is optional on vehicles which are not forward control. (see 12.5)
- 15.2.3. **Adjustment**
- 15.2.3.1. If a Class I mirror is fitted, it shall be capable of being adjusted by the driver from driving position.
- 15.2.3.2. If a Class II, III, IV or VII mirror is fitted on the driver's side, it shall be capable of being adjusted from inside the vehicle while the door is closed, although the window may be open. The mirror may, however, be locked in position from the outside.

15.2.3.3. The requirements of clause 15.2.3.2 do not apply to mirrors which, after having been knocked out of alignment, may be returned to their former position without the need for adjustment.

15.2.4. **Fields of vision**

15.2.4.1. **Class I rear-view device**

The field of vision shall be such that the driver is able to see at least a 20 m wide, flat, horizontal portion of the road centred on the vertical longitudinal median plane of the vehicle and extending from 60 m behind the driver's ocular points (Figure 4) to the horizon.

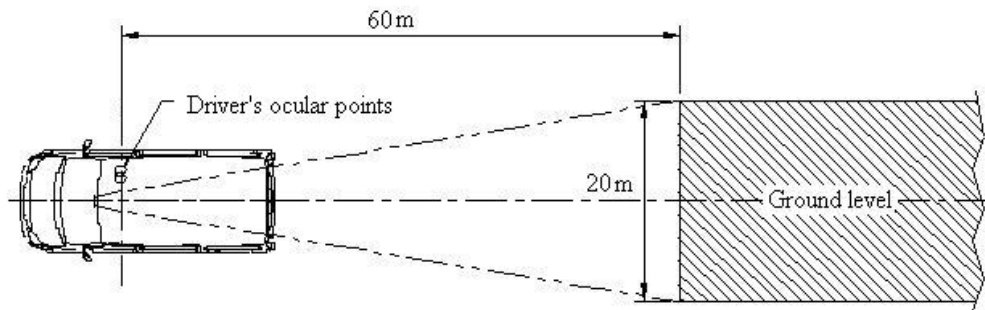

Figure 4
Class I Field of vision of

15.2.4.2 **Class II Main rear-view device**

15.2.4.2.1 main rear-view device on the driver's side

The field of vision shall be such that the driver is able to see at least a 5 m wide, flat, horizontal portion of the road, which is bounded by a plane which is parallel to the median longitudinal vertical plane and passing through the outermost point of the vehicle on the driver's side of the vehicle and extends from 30 m behind the driver's ocular points to the horizon.

In addition, the road shall be visible to the driver over a width of 1 m, which is bounded by a plane parallel to the median longitudinal vertical plane and passing through the outermost point of the vehicle starting from a point 4 m behind the vertical plane passing through the driver's ocular points (see Figure 5).

15.2.4.2.2. **Main rear-view mirror device on the passenger's side**

The field of vision shall be such that the driver is able to see at least a 5 m wide, flat, horizontal portion of the road, which is bounded on the passenger's side by a plane parallel to the median longitudinal vertical plane of the vehicle and passing through the outermost point of the vehicle on the passenger's side and which extends from 30 m behind the driver's ocular points to the horizon.

In addition, the road shall be visible to the driver over a width of 1 m, which is bounded by a plane parallel to the median longitudinal vertical plane and passing through the outermost point of the vehicle starting from a point 4 m behind the vertical plane passing through the driver's ocular points (see Figure 5).

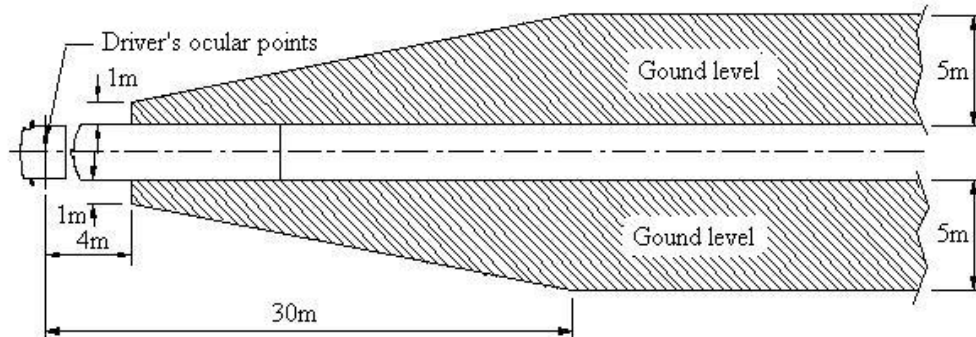

Figure 5
Class II Field of vision of

15.2.4.3 Class III Main rear-view device

15.2.4.3.1. Main rear-view device on the driver's side

The field of vision shall be such that the driver is able to see at least a 4 m wide, flat, horizontal portion of the road, which is bounded by a plane parallel to the median longitudinal vertical plane and passing through the outermost point of the vehicle on the driver's side of the vehicle and extends from 20 m behind the driver's ocular points to the horizon (see Figure 6).

In addition, the road shall be visible to the driver over a width of 1 m, which is bounded by a plane parallel to the median longitudinal vertical plane and passing through the outermost point of the vehicle starting from a point 4 m behind the vertical plane passing through the driver's ocular points.

15.2.4.3.2 Main rear-view device on the passenger's side

The field of vision shall be such that the driver is able to see at least a 4 m wide flat, horizontal portion of the road which is bounded by a plane parallel to the median longitudinal vertical plane passing through the outermost point of the vehicle on the passenger's side and which extends from 20 m behind the driver's ocular points to the horizon (see Figure 6).

In addition, the road shall be visible to the driver over a width of 1 m, which is bounded by a plane parallel to the median longitudinal vertical plane and passing through the outermost point of the vehicle starting from a point 4 m behind the vertical plane passing through the driver's ocular points.

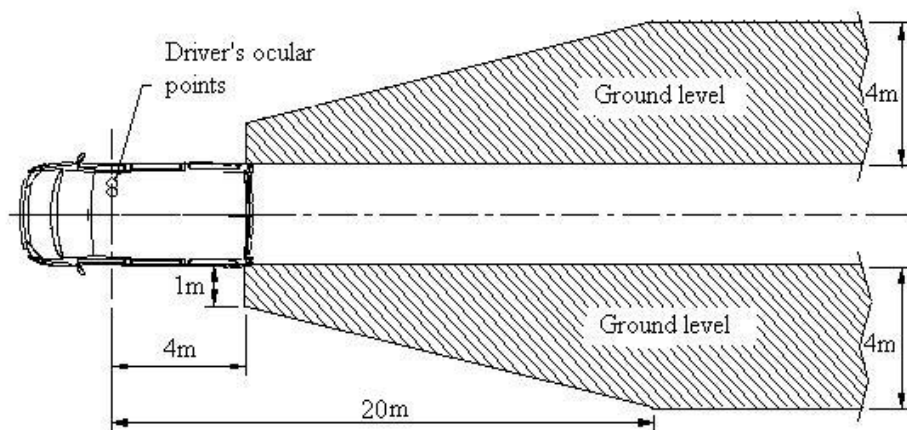

Figure 6
Class III Field of vision of

15.2.4.4. Class IV "Wide-angle" view device

15.2.4.4.1. "Wide-angle" view device on the driver's side

The field of vision shall be such that the driver is able to see at least a 15 m wide, flat, horizontal portion of the road, which is bounded by a plane parallel to the median longitudinal vertical plane of the vehicle and passing through the outermost point of the vehicle on the driver's side and which extends from at least 10 m to 25 m behind the driver's ocular points.

In addition, the road shall be visible to the driver over a width of 4.5 m, which is bounded by a plane parallel to the median longitudinal vertical plane and passing through the outermost point of the vehicle starting from a point 1.5 m behind the vertical plane passing through the driver's ocular points (see Figure 7).

15.2.4.4.2. "Wide-angle" view device on the passenger's side

The field of vision shall be such that the driver is able to see at least a 15 m wide, flat, horizontal portion of the road, which is bounded by a plane parallel to the median longitudinal vertical plane of the vehicle and passing through the outermost point of the vehicle on the passenger's side and which extends from at least 10 m to 25 m behind the driver's ocular points.

In addition, the road shall be visible to the driver over a width of 4.5 m, which is bounded by a plane parallel to the median longitudinal vertical plane and passing through the outermost point of the vehicle starting from a point 1.5 m behind the vertical plane passing through the driver's ocular points (see Figure 7).

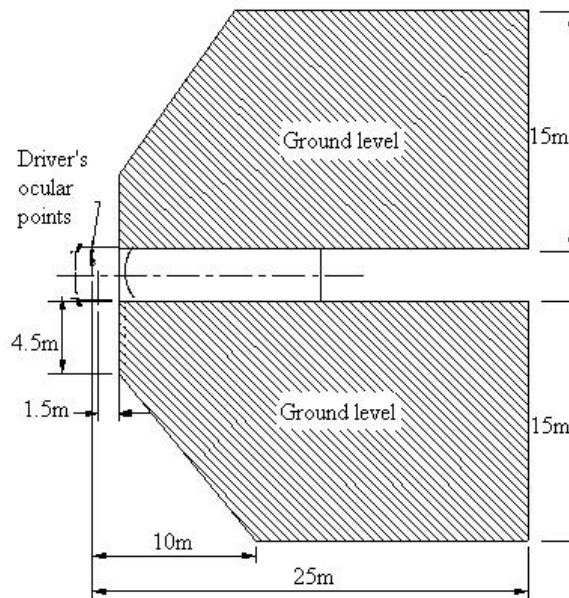

Figure 7
Class IV Field of vision

15.2.4.5. " Class V close-proximity view device

The field of vision shall be such that the driver is able to see a flat horizontal portion of the road along the side of the vehicle, bounded by the following vertical planes (see Figures 8a and 8b):

- 15.2.4.5.1 The plane parallel to the median longitudinal vertical plane of the vehicle which passes through the outermost point of the vehicle cab on the passenger's side;
- 15.2.4.5.2. in the transverse direction, the parallel plane passing at a distance of 2 m in front of the plane mentioned in clause 15.2.4.5.1. above
- 15.2.4.5.3. to the rear, the plane parallel to the vertical plane passing through the driver's ocular points and situated at a distance of 1.75 m behind that plane;
- 15.2.4.5.4. to the front, the plane parallel to the vertical plane passing through the driver's ocular points and situated at a distance of 1 m in front of that plane. If the vertical transverse plane passing through the leading edge

of the vehicle bumper is less than 1 m in front of the vertical plane passing through the driver's ocular points, the field of vision shall be limited to that plane.

- 15.2.4.5.5. In case the field of vision described in Figures 8a and 8b is able to be perceived through the combination of the field of vision from a Class IV wide-angle view device and that of a Class VI front view device, the installation of a Class V close proximity view device is not compulsory.

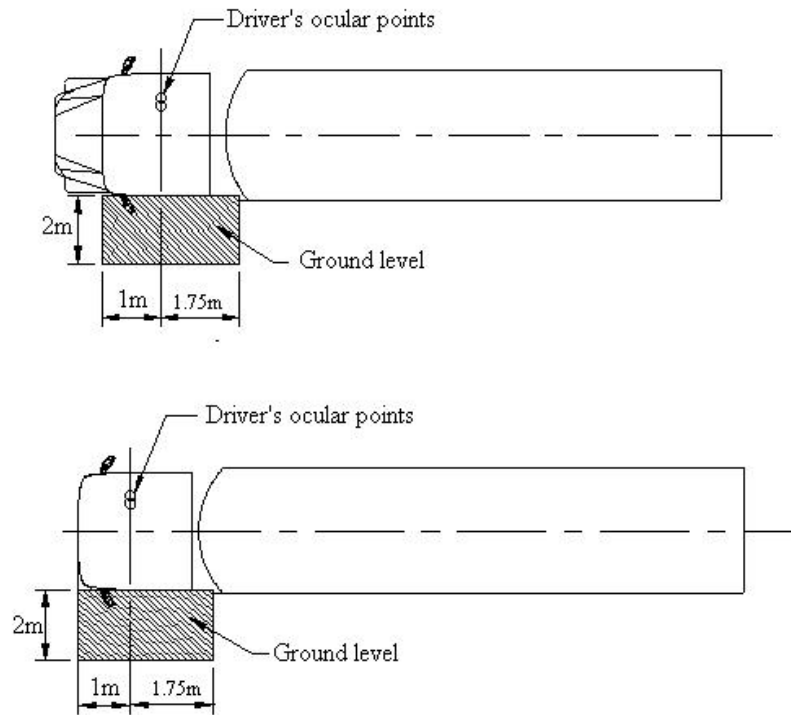

Figures 8a and 8b
Class V Field of vision

- 15.2.4.5.6 On the passenger side only, the field of vision shall also be such that the driver can see a flat horizontal portion of the road along the side of the vehicle which is outside the field defined in clauses 15.2.4.5.1. to 15.2.4.5.4. above but within the field bounded by the following vertical planes; the front of this field of vision may be rounded off with a radius of 2,000 mm (see Figures 8c and 8d):
- 15.2.4.5.7 In the transverse direction, the parallel plane passing at a distance of 4.5 m in front of the plane mentioned in clause 15.2.4.5.1. above.
- 15.2.4.5.8 To the rear, the plane parallel to the vertical plane passing through the driver's ocular points and situated at a distance of 1.75 m behind that plane.
- 15.2.4.5.9 To the front, the plane parallel to the vertical plane passing through the driver's ocular points and situated at a distance of 3 m in front of that plane. This field of vision may be partially provided by a front-view device (Class VI).

- 15.2.4.5.10 The field of vision prescribed in clause 15.2.4.5.6. to 15.2.4.5.9. above may be partially provided by a wide-angle view device (Class IV) or a combination of a close-proximity view device (Class V) and a front-view device Class VI).
- 15.2.4.5.11 The area prescribed in clause 15.2.4.5.6. to 15.2.4.5.9. above may be viewed using a combination of direct view and indirect vision devices (of Class IV, V, VI).
- 15.2.4.5.11.1 If an indirect vision device of Class IV is used to provide a part of the field of vision prescribed in clause 15.2.4.5.6. to 15.2.4.5.9., its shall be adjusted in a way that it simultaneously provides the field of vision prescribed in clause 15.2.4.4.2.
- 15.2.4.5.11.2 If an indirect vision device of Class V is used to provide a part of the field of vision prescribed in clause 15.2.4.5.6. to 15.2.4.5.9., it shall be adjusted in a way that it simultaneously provides the field of vision prescribed in clauses 15.2.4.5.1. to 15.2.4.5.4
- 15.2.4.5.11.3 If an indirect vision device of Class VI is used to provide a part of the field of vision prescribed in clause 15.2.4.5.6. to 15.2.4.5.9., it shall be adjusted in a way that it simultaneously provides the field of vision prescribed in clause 15.2.4.6.1.
- 15.2.4.5.12 The field of vision prescribed in clauses 15.2.4.5.1. to 15.2.4.5.4. may be viewed using a combination of a close-proximity view device (Class V) and a wide-angle view device (Class IV).
In such cases the close-proximity view mirror (Class V) shall provide at least 90 per cent of the field of vision prescribed in clause 15.2.4.5.1 to 15.2.4.5.4. and the Class IV mirror shall be adjusted in a way that it simultaneously provides the field of vision prescribed in clause 15.2.4.4.2.
- 15.2.4.5.13 Clause 15.2.4.5.6. to 15.2.4.5.12. above shall not apply to a vehicle where any part of a Class V mirror, if fitted, or its holder, is less than 2.4 m above the ground, regardless of its position after adjustment.
- 15.2.4.5.14. Clause 15.2.4.5.6. to 15.2.4.5.12. above shall not apply to a vehicle of category M2 or M3.

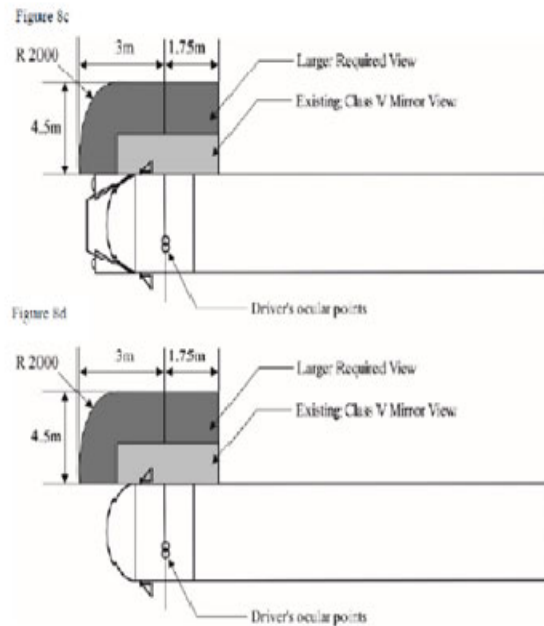

**Figures 8c and 8d –
Larger field of vision on the passenger side**

15.2.4.6.

Class VI front-view device

- a transverse vertical plane through the outermost point of the front of the vehicle,
- a transverse vertical plane 2000 mm in front of the plane defined in (a),
- a longitudinal vertical plane parallel to the longitudinal vertical median plane going through the outermost side of the vehicle at the driver's side and,
- a longitudinal vertical plane parallel to the longitudinal vertical median plane 2000 mm outside the outermost side of the vehicle opposite to the driver's side

The front of this field of vision opposite to the driver's side may be rounded off with a radius of 2,000 mm (see Figure 9).

For the defined field of vision, see also clause 15.2.4.9.2.

The provisions for Class VI front view device are compulsory for forward controlled (as defined in clause 12.5) vehicles of categories $N_2 > 7.5$ t and N_3 .

If vehicles of these categories cannot fulfil the requirements by using a front-view device, a vision support system shall be used. In the case of a vision support system this device shall be able to detect an object of 50 cm height and with a diameter of 30 cm within the field defined in figure 9.

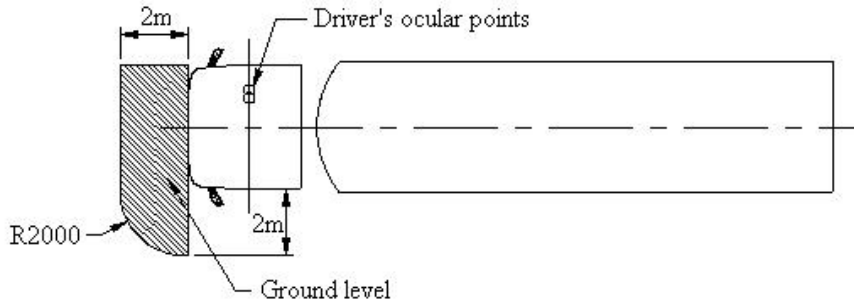

Figure 9
Class VI Field of vision of

15.2.4.6.2. However, if the driver is able to see, taking into account the obstructions by the A-pillars, a straight line 300 mm in front of the vehicle at a height of 1,200 mm above the road surface and which is situated between a longitudinal vertical plane parallel to the longitudinal vertical median plane going through the outermost side of the vehicle at the driver's side and a longitudinal vertical plane parallel to the longitudinal vertical median plane 900 mm outside the outermost side of the vehicle opposite to the driver's side, a Class VI device for indirect vision is not mandatory.

15.2.4.7. Class VII main rear-view mirror

15.2.4.7.1. Main rear-view mirror on the driver's side

The field of vision shall be such that the driver is able to see at least a 2.50 m wide, flat, horizontal portion of the road, which is bounded by a plane parallel to the median longitudinal vertical plane and passing through the outermost point of the vehicle on the driver's side of the vehicle and extends from 10 m behind the driver's ocular points to the horizon (see Figure 10).

15.2.4.7.2. Main rear-view mirror on the passenger's side

The field of vision shall be such that the driver is able to see at least a 4 m wide flat, horizontal portion of the road which is bounded by a plane parallel to the median longitudinal vertical plane passing through the outermost point of the vehicle on the passenger's side and which extends from 20 m behind the driver's ocular points to the horizon (see Figure 10).

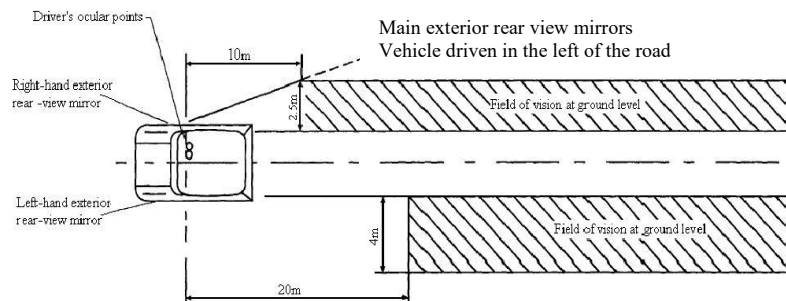

Figure 10
Class VII Field of vision of

15.2.4.8. In the case of mirrors consisting of several reflecting surfaces which are either of different curvature or make an angle with each other, at least one of the reflecting surfaces shall provide the field of vision and have the dimensions (6.1.2.1.2.2 of AIS-001 (Part 1) (Rev. 2)) specified for the class to which they belong.

15.2.4.9. **Obstructions**

15.2.4.9.1. **Class I rear-view device**

The field of vision may be reduced by the presence of devices such as, sun visors, windscreen wipers, heating elements and stop lamp of category S3, provided that all these devices together do not obscure more than 15 percent of the prescribed field of vision. Headrest or framework or bodywork such as window columns of rear split doors, rear window frames shall be excluded from the calculations. This requirement shall be tested by projection on to a vertical plane at right angle to the longitudinal centre plane of the vehicle. The degree of obstruction shall be measured with the sun visors folded back.

15.2.4.9.2. **Classes II, III, IV, V, and VI devices for indirect vision and Class VII mirrors**

In the fields of vision specified above, obstruction due to the bodywork and its components, such as other cab devices for indirect vision, door handles, outline marker lights, direction indicators and front and rear bumpers, as well as reflective-surface cleaning components, shall not be taken into account if they are responsible for a total obstruction of less than 10 percent of the specified field of vision. In the case of a vehicle designed and constructed for special purposes where, due to its special features, it is not possible to meet this requirement, the obstruction of the required field of vision of a Class VI mirror caused by the special features may be more than 10 percent but not more than necessary for its special function.

15.2.4.10 **Test procedure**

The field of vision shall be determined by placing powerful light sources at the ocular points and examining the light reflected on the vertical monitoring screen. Other equivalent methods may be used.

16. REQUIREMENT FOR DEVICES FOR INDIRECT VISION OTHER THAN MIRRORS

16.1 **Class I to IV camera-monitor devices (see Annex M)**

Unless otherwise provided in this standard, the definitions and symbols used in clause 16.1. are in accordance with ISO 16505:2015, Chapters 3 and 4.

Unless otherwise provided in this standard the requirements given in clause 16.1. shall be verified according to the test procedures given in ISO 16505:2015, Chapter 7, where available.

16.1.1 Intended use, activation and deactivation

The intended use shall be mentioned within the operator's manual. The procedure for activation and deactivation of the CMS of Classes II and III shall allow a safe use of the vehicle.

The CMS shall be activated when the vehicle is opened (e.g. unlocking of the doors, opening of a front door or any other means by the choice of the manufacturer).

In addition to the requirements mentioned in clause 15.2.1.1.2., after each engine switch-off the system shall remain operational for a period of at least $T1 = 120$ s. After $T1$ period and for a period of at least $T2 = (420 - T1)$ seconds the system shall be able to be reactivated such that the required field of vision is made available within 1 second by manoeuvring any front door opening automatically and, if available, manually by the driver. After $T2$ period the system shall be able to be reactivated within 7 seconds (e.g. by initiating any front door opening process).

Notwithstanding the provisions above, any other concept to activate or deactivate the system shall be demonstrated to the satisfaction of the testing agency within the safety concept that is provided according to the provisions in Annex M, clause 2.

16.1.1.1 Default view

In default view the CMS shall show the field of view at least as defined in clause 15.2.4., with at least the required magnification and resolution as defined in clause 16.1.3.

In the case of mirror and CMS dual function system of Class I, the CMS mode shall be set by the driver. Activation and deactivation device shall be located directly on the mirror and CMS dual function system.

16.1.1.1.1 Temporarily modified view

To enable an improved view in special manoeuvres (e.g., where in the case of conventional mirrors the field of view is usually changed by the driver moving their head to achieve incident angle to the mirror), it shall be permitted to change temporarily the field of view, so that the requirements laid down in clause 15.2.4. (Field of vision) and 16.1.3. (Magnification and resolution) may not be fulfilled during this temporarily modified view.

The operation of this function shall be intuitive to the driver and not cause additional safety risks such as additional blind spots. In the case of articulated vehicles, this includes an adaptation of the modified view to cover the full length of the vehicle combination. The operation of the function shall cease, when the maneuver has been completed and the CMS shall return to the default view.

It shall be indicated to the driver, that a temporarily modified view is displayed. At any time, the driver shall be able to deactivate the function. The operator's manual shall inform the driver accordingly.”
The vehicle manufacturer shall demonstrate the improvement of the view by an analysis to the satisfaction of the Testing agency.

16.1.1.2. Luminance and contrast adjustment

If manual adjustment is provided, the operator's manual shall provide information on how to change the luminance/contrast.

16.1.1.3. Overlay requirements within the minimum required field of vision
Overlays shall display only safety-related rearward vision information. All overlays shall be considered as an obstruction regardless of their transparency.

Each overlay shall not exceed 2.5 per cent of the required field of view displayed surface of the corresponding class.

The total surface of all obstructions shall not exceed the provision of clause 15.2.4.9.1. or 15.2.4.9.2. at the same time.

Overlay and any other obstruction surface shall be determined (for example on screenshots) taking into account the worst case(s).

16.1.2. Operating readiness (System availability)

Non-operation of the system shall be recognizable to the driver is (e.g. CMS failure by, i.e. warning indication, display information, absence of status indicator). The information for the driver shall be explained in the operator's manual.

16.1.3. Magnification and resolution

16.1.3.1. Magnification factor

The minimum and the average magnification factors of the CMS, in both horizontal and vertical directions shall not be lower than the magnification factors indicated below.

The minimum magnification factor shall not be less than:

- (a) for Class I: 0.31;
- (b) for Class II (driver's side): 0.26;
- (c) for Class III (driver's side): 0.29;
- (d) for Class IV (driver's side): 0.054;
- (e) for Class II (passenger's side): 0.13;
- (f) for Class III (passenger's side): 0.19;
- (g) for Class IV (passenger's side): 0.016.

The average magnification factor shall not be less than:

- (h) for Class I: 0.33;
- (i) for Class II (driver's side): 0.31;
- (j) for Class III (driver's side): 0.31;
- (k) for Class IV (driver's side): 0.091;
- (l) for Class II (passenger's side): 0.16;
- (m) for Class III (passenger's side): 0.20;
- (n) for Class IV (passenger's side): 0.046

16.1.3.2. Resolution (MTF)

The resolution (MTF) defines the minimum distinguishable details observable in an image as is represented by the MTF10. For reasons of simplicity the requirement is defined assuming an aspect ratio of 1:1.

Resolution MTF10, at the centre of the monitor defined size shall fulfil the following requirements

$$MTF10_{(1:1)/hor} \geq MTF10_{MIN(1:1)/hor}, \quad \text{in horizontal direction}$$

$$MTF10_{(1:1)/ver} \geq MTF10_{MIN(1:1)/ver}, \quad \text{in vertical direction}$$

Resolution MTF10, at the corner measurement points as illustrated in the figure below shall fulfil the following requirements:

$$MTF10_{(1:1)/hor} \geq \frac{1}{2} MTF10_{MIN(1:1)/hor}, \quad \text{in horizontal direction}$$

$$MTF10_{(1:1)/ver} \geq \frac{1}{2} MTF10_{MIN(1:1)/ver}, \quad \text{in vertical direction}$$

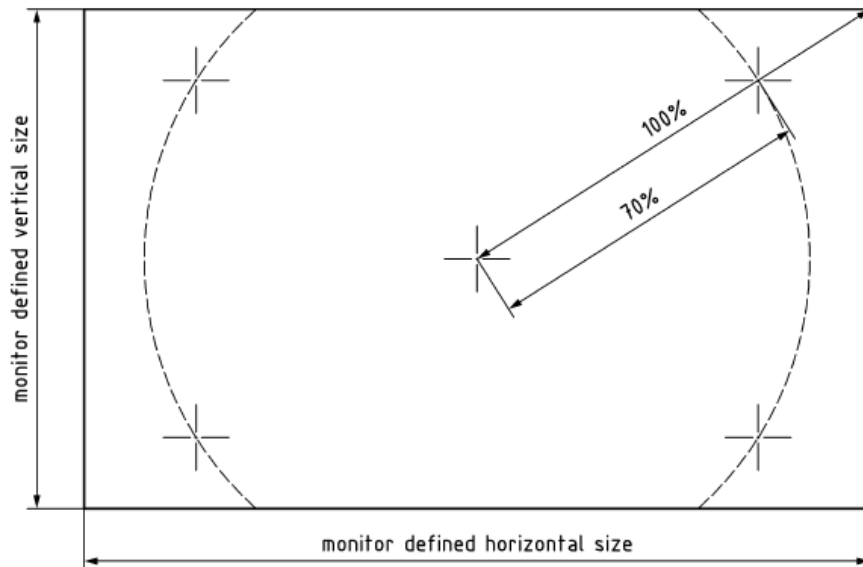

16.1.4 Magnification aspect ratio

In the required field of view, the difference between the average magnification factor for horizontal and vertical direction of a CMS shall satisfy the following equations depending on the individual mirror classes.

For devices Class I the acceptable range shall be:

$$-0.34 \leq 1 - \frac{M_{system/hor/avg}}{M_{system/ver/avg}} \leq 0.25$$

For devices Class II the acceptable range shall be:

$$-0.42 \leq 1 - \frac{M_{system/hor/avg}}{M_{system/ver/avg}} \leq 0.3$$

For devices Class III the acceptable range shall be:

$$-0.34 \leq 1 - \frac{M_{system/hor/avg}}{M_{system/ver/avg}} \leq 0.25$$

For devices Class IV no restriction in magnification ratio is required.

16.1.5. Monitor inside the vehicle

16.1.5.1. The centre of the monitor(s) shall not be below a plane passing through the driver's ocular points, as defined in clause 12.1., and declined 30° below.

16.1.5.2. The arrangement of the monitor(s) inside the vehicle shall be convenient to the driver.

Thus, the image of the right-side field of view shall be presented to the right of the longitudinal vertical plane through the ocular reference point, defined in clause 12.6. The image of the left side field of view shall be presented to the left of the longitudinal vertical plane through the ocular reference point.

If the CMS shows more than one field of vision on the same display, non-continuous images shall be clearly separated from each other. If the field of vision from different classes of devices for indirect vision are shown on the monitor(s) without hiding any part of the required field of vision, a combined continuous image is allowed. In this case, a clear separation of the different fields of vision is not necessary and any changes in magnification may be indicated to the driver using indication lines. Indication lines shall not hide information

16.1.5.3. The monitor defined size shall be visible without any obstruction from the ocular reference point. A virtual testing is acceptable.

16.1.6. Obstruction of the driver's direct view caused by the installation of a device for indirect vision shall be restricted to a minimum

- 16.1.7 Decreasing accommodation
- The installation of the monitor inside the vehicle should follow the needs of the intended user group. The operator's manual shall provide information on the decreasing capacity of the human being to accommodate and shall recommend suitable assistance for the user's needs.
- 16.1.8. Safety of electronic systems for indirect vision
- The requirements to be applied to the safety aspects of electronic systems for indirect vision are given in Annex M, clause 2.
- 16.2. **Classes V and VI Camera-monitor devices**
- 16.2.1 A device for indirect vision shall give such performances that a critical object can be observed by the driver over the entire required field of vision, taking into account the critical perception according the procedure of Annex K.
- Alternatively, the determination of the displayed object size shall be performed according to Annex L.
- 16.2.2. Obstruction of the driver's direct view caused by the installation of a device for indirect vision shall be restricted to a minimum.
- 16.2.3 Installation requirements for the monitor
- The viewing direction of the monitor shall roughly be the same direction as the one for the main mirror.
- 16.2.4 Vehicles may be equipped with additional devices for indirect vision.
- 16.2.5 The provisions of this standard do not apply to the surveillance camera-monitor-recording devices defined in 2.3 of AIS-001(Part1) (Rev.2). Exterior surveillance cameras either shall be mounted at least 2 m above the ground when the vehicle is under a load corresponding to its maximum technical permissible mass, or, if their lower edge is less than 2 m from the ground, shall not project more than 50 mm beyond the overall width of the vehicle measured without this device and have a radius of curvature of not less than 2.5 mm
- 17 MODIFICATIONS OF THE VEHICLE TYPE AND EXTENSION OF TYPE APPROVAL**
- 17.1 Every functional modification in technical specifications pertaining to installation of rear-view mirror declared in accordance with clause 13.1 shall be intimated to the testing agency. Testing agency may then consider, whether,
- 17.1.1 Vehicle with modifications complies with specified requirements, or,
- 17.1.2 any testing is required.
- 17.2 For considering whether testing is required or not, guidelines given in Annex M shall be followed.

17.3 In case of 17.1.2, checks for those parameters which are affected by the modifications only need to be carried out.

17.4 In the event of. 17.1.1. or in the case of 17.1.2 after successful compliance to requirements, the certificate of compliance shall be validated for the modified version.

18 CONFORMITY OF PRODUCTION

Every vehicle approved under this standard shall be so manufactured as to conform to the type approved by meeting the requirements set out in clause 15 or 16 as applicable

Note: Verification of conformity of production will be applicable when the Whole Vehicle COP procedure is implemented.

19 to 21 Reserved

22 TRANSITIONAL PROVISIONS

22.1 At the request of the applicant, type approvals for compliance to AIS-002 (Part 1) (Rev. 2): 2023, shall be granted by testing agencies from 17th May 2023 (date of adoption of this standard in CMVR-TSC). Such type approvals shall be deemed to be compliance to AIS-002 (Part 1) (Rev.1):2011.

22.2 At the request of applicant, type approval to the compliance to AIS-002 (Part 1) (Rev.1):2011 shall be granted up to the notified date of implementation of AIS-002 (Part 1) (Rev. 2): 2023.

22.3 Type approvals issued for compliance to AIS-002 (Part 1) (Rev.1):2011 shall:

22.3.1 be extended for L category vehicles without any further verification, for compliance to AIS-002 (Part 1) (Rev. 2): 2023.

22.3.2 not be extended for M and N category vehicles for compliance to AIS-002 (Part 1) (Rev. 2): 2023.

Note: Additional verification for the above need not be carried out, if compliance to the above requirements has already been established during the type approval as per AIS-002 (Part 1) (Rev.1):2011.

22.4 Extension of Approvals for engineering and administrative changes:

22.4.2 In the case of 21.1, extensions shall be granted subject to the conditions of AIS-002 (Part 1) (Rev. 2): 2023. Such extensions shall be deemed to be compliance to AIS-002 (Part 1) (Rev.1):2011.

22.4.2 In the case of 21.2, extensions shall be granted subject to conditions of AIS-002 (Part 1) (Rev.1):2011 till the notified date of implementation of AIS-002 (Part 1) (Rev.2): 2023.

23 AMENDMENTS TO UN REGULATIONS AFTER THE LEVEL DESCRIBED IN 0.3 OF INTRODUCTION

23.1 Supplements

In case of changes in UN regulation, which are issued as supplements (Supplements do not affect the earlier type approvals) at the request of applicant, approval of compliance to this standard shall be issued taking into account the changes arising out of such supplement(s) to UN regulation with approval from Chairman AISC.

This shall be incorporated in the test report.

Note: Such changes will be considered for inclusion in this standard at the time of its next amendment /revision.

23.2 Series of amendments

Changes in UN regulation, which are issued as series of amendments (series of amendments may affect the earlier type approvals) will not be considered for issuing approval to this standard.

However, Chairman, AISC may, on a case to case basis, permit to accept latest series of amendments.

This shall be incorporated in the test report.

Note: Such changes will be considered for inclusion in this standard at the time of its next revision.

ANNEX A
(Reserved)

ANNEX B

(See 13.1)

**INFORMATION TO BE SUBMITTED AT THE TIME
OF TYPE APPROVAL**

B-1 The specification submitted by manufacturer (applicant) at the time of applying for the type approval of the vehicle to this standard shall contain at least the information set out in the following entries of AIS-007 (Revision 5):

Table 1A 0.1 to 0.9, 1.2 and 9 of detailed specifications (For L category vehicles only)

Table 2 A1.1, A1.7.1, A.2.1, A.2.1.1, A.2.1.2, A2.2, A2.1.5 (For M and N category vehicles)

Table 3 B1.2, B27.1 to B27.8 (For M and N category vehicles)

Following additional information shall also be provided along with the type approval application.

1. In case of L-category vehicles – with bodywork / without bodywork.
2. Photograph(s) and/or drawing(s) of a representative vehicle:
3. Optional equipment which may affect the rearward field of vision:
4. A brief description of the electronic components (if any) of the adjustment device:
5. Sketch(es) showing R point, seat back angle and the position of the mirror relative to the vehicle structure, including methods of attachment and relevant dimensions as applicable
6. Devices for indirect vision other than mirrors:
7. Sufficiently detailed drawings of devices for indirect vision other than mirrors, with the installation instructions:

In the case of camera-monitor system of Classes I to IV:

1. Drawing(s)/photograph(s) showing the position of the camera(s) relative to the vehicle structure:
2. Drawing(s)/photograph(s) showing the arrangement of the monitor(s) including surrounding interior parts:
3. Drawing(s)/photograph(s) showing the drivers view onto the monitor(s):

4. Drawing(s)/photograph(s) showing the setup and monitor image of the required field of view:
5. Details of the method of attachment of the camera-monitor device(s) including that part of the vehicle structure to which it is attached:
6. Optional equipment which may affect the rearward field of vision:
7. A brief description of the electronic components (if any) of the adjustment device:
8. A technical specification and operator's manual of the camera-monitor system according to ISO 16505:2015:
9. Documentation referred to in paragraph 16.1.1.1.1., if applicable

B-2 If the above information is submitted as per AIS-007 (Rev. 5) for approval of the complete vehicle it is not necessary to submit information in the above format. In addition, the information required in sketch form may be combined with information needed for other standards.

ANNEX C to ANNEX G

(Reserved)

ANNEX H

(See 12.1.)

PROCEDURE FOR DETERMINING THE "H" POINT AND THE ACTUAL TORSO ANGLE FOR SEATING POSITIONS IN MOTOR VEHICLES**H-1. PURPOSE**

The procedure described in this Annex is used to establish the "H" point location and the actual torso angle for one or several seating positions in a motor vehicle and to verify the relationship of measured data to design specifications given by the vehicle manufacturer.

Note: In any seating position other than front seats where the "H" point cannot be determined using the "Three-dimensional 'H' point machine" or procedures, the "R" point indicated by the manufacturer may be taken as a reference at the discretion of the testing agency.

H-2. DEFINITIONS

For the purposes of this Annex:

- H-2.1. **"Reference data"** means one or several of the following characteristics of a seating position:
- H-2.1.1. the "H" point and the "R" point and their relationship;
 - H-2.1.2. the actual torso angle and the design torso angle and their relationship.
- H-2.2. **"Three-dimensional 'H' point machine"** (3-D H machine) means the device used for the determination of "H" points and actual torso angles. This device is described in Annex HA
- H-2.3. **"'H' point"** means the pivot centre of the torso and thigh of the 3-D H machine installed in the vehicle seat in accordance with H-4 below. The "H" point is located in the centre of the centreline of the device which is between the "H" point sight buttons on either side of the 3-D H machine. The "H" point corresponds theoretically to the "R" point (for tolerances see H-3.2.2). Once determined in accordance with the procedure described in H-4, the "H" point is considered fixed in relation to the seat-cushion structure and to move with it when the seat is adjusted.
- H-2.4. **"'R' point" or "seating reference point"** means a design point defined by a vehicle manufacturer for each seating position and established with respect to the three-dimensional reference system;
- H-2.5. **"Torso-line"** means the centreline of the probe of the 3-D H machine with the probe in the fully rearward position.
- H-2.6. **"Actual torso angle"** means the angle measured between a vertical line through the "H" point and the torso line using the back-angle quadrant on the 3-D H machine. The actual torso angle corresponds theoretically to the design torso angle (for tolerances see H-3.2.2.).

- H-2.7. **"Design torso angle"** means the angle measures between a vertical line through the "R" point and the torso line in a position which corresponds to the design position of the seat-back established by the vehicle manufacturer.
- H-2.8. **"Centreplane of occupant"** (C/LO) means the median plane of the 3-D H machine positioned in each designated seating position; it is represented by the co-ordinate of the "H" point on the "Y" axis. For individual seats, the centreplane of the seat coincides with the centreplane of the occupant. For other seats, the centreplane of the occupant is specified by the manufacturer;
- H-2.9. **"Three-dimensional reference system"** means a system as described in Annex HB.
- H-2.10. **"Fiducial marks"** are physical points (holes, surfaces, marks or indentations) on the vehicle body as defined by the manufacturer;
- H-2.11. **"Vehicle measuring attitude"** means the position of the vehicle as defined by the co-ordinates of fiducial marks in the three-dimensional reference system

H-3. REQUIREMENTS

H-3.1. Data presentation

For each seating position where reference data are required in order to demonstrate compliance with the provisions of the present standard, all or an appropriate selection of the following data shall be presented in the form indicated in Annex HC.

- H-3.1.1. the co-ordinates of the "R" point relative to the three-dimensional reference system;
- H-3.1.2. the design torso angle;
- H-3.1.3. all indications necessary to adjust the seat (if it is adjustable) to the measuring position set out in H-4.3.

H-3.2. Relationship between measured data and design specifications

- H-3.2.1. The co-ordinates of the "H" point and the value of the actual torso angle obtained by the procedure set out in H-4 shall be compared, respectively, with the co-ordinates of the "R" point and the value of the design torso angle indicated by the vehicle manufacturer.
- H-3.2.2. The relative positions of the "R" point and the "H" point and the relationship between the design torso angle and the actual torso angle shall be considered satisfactory for the seating position in question if the "H" point, as defined by its co-ordinates, lies within a square of 50 mm side length with horizontal and vertical sides whose diagonals intersect at the "R" point, and if the actual torso angle is within 5 degree of the design of the torso angle.

- H-3.2.3. If these conditions are met, the "R" point and the design torso angle, shall be used to demonstrate compliance with the provisions of this standard.
- H-3.2.4. If the "H" point or the actual torso angle does not satisfy the requirements of H-3.2.2, the "H" point and the actual torso angle shall be determined twice more (three times in all). If the results of two of these three operations satisfy the requirements, the conditions of H-3.2.3 shall apply.
- H-3.2.5. If the results of at least two of the three operations described H-3.2.4 do not satisfy the requirements of H-3.2.2, or if the verification is not to carry out because the vehicle manufacturer has failed to supply information regarding the position of the "R" point or regarding the design torso angle, the centroid of the three measured points or the average of the three measured angles shall be used and be regarded as applicable in all cases where the "R" point or the design torso angle is referred to in this standard.

H-4. PROCEDURE FOR "H" POINT AND ACTUAL TORSO ANGLE DETERMINATION

- H-4.1. The vehicle shall be preconditioned at the manufacturer's discretion, at a temperature of $20 \pm 10^{\circ}\text{C}$ to ensure that the seat material reaches the room temperature. If the seat to be checked has never been sat upon, a 70 to 80 kg person or device shall sit on the seat twice for one minute to flex the cushion and back. At the manufacturer's request, all seat assemblies shall remain unloaded for a minimum period of 30 min prior to installation of the 3-D H machine.
- H-4.2. The vehicle shall be at the measuring attitude defined in H-2.11.
- H-4.3. The seat, if it is adjustable, shall be adjusted first to the rearmost normal driving or riding position, as indicated by the vehicle manufacturer, taking into consideration only the longitudinal adjustment of the seat, excluding seat travel used for purposes other than normal driving or riding positions. Where other modes of seat adjustment exist (vertical, angular, seat-back, etc.) these will be then adjusted to the position specified by the vehicle manufacturer. For suspension seats, the vertical position shall be rigidly fixed corresponding to a normal driving position as specified by the manufacturer.
- H-4.4. The area of the seating position contacted by the 3-D H machine shall be covered by a muslin cotton, of sufficient size and appropriate texture, described as a plain cotton fabric having 18.9 threads per/cm² and weighing 0.228 kg/m² or knitted or non-woven fabric having equivalent characteristics.

If test is run on a seat outside the vehicle, the floor on which the seat is placed shall have the same essential characteristics e.g. tilt angle, height difference with a seat mounting, surface texture, etc, as the floor of the vehicle in which the seat is intended to be used.

- H-4.5. Place the seat and back assembly of the 3-D H machine so that the centreplane of the occupant (C/LO) coincides with the centreplane of the 3-D H machine. At the manufacturer's request, the 3-D H machine may be moved inboard with respect to the C/LO if the 3-D H machine is located so far outboard that the seat edge will not permit levelling of the 3-D H machine.
- H-4.6. Attach the foot and lower leg assemblies to the seat pan assembly, either individually or by using the T-bar and lower leg assembly. A line through the "H" point sight buttons shall be parallel to the ground and perpendicular to the longitudinal centre-plane of the seat.
- H-4.7. Adjust the feet and leg positions of the 3-D H machine as follows:
- H-4.7.1. Designated seating position: driver and outside front passenger
- H-4.7.1.1. Both feet and leg assemblies shall be moved forward in such a way that the feet take up natural positions on the floor, between the operating pedals if necessary. Where possible the left foot shall be located approximately the same distance to the left of the centreplane of the 3-D H machine as the right foot is to the right. The spirit level verifying the transverse orientation of the 3-D H machine is brought to the horizontal by readjustment of the seat pan if necessary, or by adjusting the leg and foot assemblies towards the rear. The line passing through the "H" point sight buttons shall be maintained perpendicular to the longitudinal centreplane of the seat.
- H-4.7.1.2. If it is not possible for the left leg be kept parallel to the right leg and is not possible for the left foot to be supported by the structure, move the left foot until it is supported. The alignment of the sight buttons shall be maintained.
- H-4.7.2. Designated seating position: outboard rear
- For rear seats or auxiliary seats, the legs are located as specified by the manufacturer. If the feet then rest on parts of the floor which are at different levels, the foot which first comes into contact with the front seat shall serve as a reference and the other foot shall be so arranged that the spirit level giving the transverse orientation of the seat of the device indicates the horizontal.
- H-4.7.3. Other designated seating positions:
- The general procedure indicated in H-4.7.1 shall be followed except that the feet shall be placed as specified by the vehicle manufacturer.
- H-4.8. Apply lower leg and thigh weights and level the 3-D H machine.
- H-4.9. Tilt the back pan forward against the forward stop and draw the 3-D H machine away from the seat-back using the T-bar. Reposition the 3-D H machine on the seat by one of the following methods:

- H-4.9.1. If the 3-D H machine tends to slide rearward, use the following procedure. Allow the 3-D H machine to slide rearward until a forward horizontal restraining load on the T-bar is no longer required, i.e. until the seat pan contacts the seat-back. If necessary, reposition the lower leg;
- H-4.9.2. If the 3-D H machine does not tend to slide rearward, use the following procedure. Slide the 3-D H machine rearwards by applying a horizontal rearward load to the T-bar until the seat pan contacts the seat-back (see Figure 2 of Annex HA).
- H-4.10 Apply a 100 ± 10 N load to the back and pan assembly of the 3-D H machine at the intersection of the hip angle quadrant and the T-bar housing. The direction of load application shall be maintained along a line passing by the above intersection to a point just above the thigh bar housing (see Figure 2 of Annex HA). Then carefully return the back pan to the seat-back. Care shall be exercised throughout the remainder of the procedure to prevent the 3-D H machine from sliding forward.
- H-4.11. Install the right and left buttock weights and then, alternately, the eight torso weights. Maintain the 3-D H machine level.
- H-4.12. Tilt the back pan forward to release the tension on the seat-back. Rock the 3-D H machine from side to side through 10° arc (5° to each side of the vertical centreplane) for three complete cycles to release any accumulated friction between the 3-D H machine and the seat.

During the rocking action, the T-bar of the 3-D H machine may tend to diverge from the specified horizontal and vertical alignment. The T-bar shall therefore be restrained by applying an appropriate lateral load during the rocking motions. Care shall be exercised in holding the T-bar and rocking the 3-D H machine to ensure that no inadvertent exterior loads are applied in a vertical or fore-and-aft direction.

The feet of the 3-D H machine are not to be restrained or held during this step. If the feet change position, they should be allowed to remain in that attitude for the moment.

Carefully return the back pan to the seat-back and check the two spirit levels for zero position. If any movement of the feet has occurred during the rocking operation of the 3-D H machine, they shall be repositioned as follows:

Alternately, lift each foot off the floor the minimum necessary amount until no additional foot movement is obtained. During this lifting, the feet are to be free to rotate; and no forward or lateral loads are to be applied. When each foot is placed back in the down position, the heel is to be in contact with the structure designed for this;

Check the lateral spirit level for zero position; if necessary, apply a lateral load to the top of the back pan sufficient to level the 3-D H machine's seat pan on the seat.

- H-4.13. Holding the T-bar to prevent the 3-D H machine from sliding forward on the seat cushion, proceed as follows:
- (a) return the back pan to the seat back;
 - (b) alternately apply and release a horizontal rearward load, not to exceed 25 N, to the back-angle bar at a height approximately at the centre of the torso weights until the hip angle quadrant indicates that a stable position has been reached after load release. Care shall be exercised to ensure that no exterior downward or lateral loads are applied to the 3-D H machine. If another level adjustment of the 3-D H machine is necessary, rotate the back pan forward, re-level, and repeat the procedure from H-4.12.
- H-4.14. Take all measurements:
- H-4.14.1. The co-ordinates of the "H" point are measured with respect to the three-dimensional reference system;
 - H-4.14.2. The actual torso angle is read at the back-angle quadrant of the 3-D H machine with the probe in its fully rearward position.
- H-4.15. If a re-run of the installation of the 3-D H machine is desired, the seat assembly should remain unloaded for a minimum period of 30 min prior to the re-run. The 3-D H machine should not be left loaded on the seat assembly longer than the time required to perform the test.
- H-4.16. If the seats in the same row are regarded as similar (bench seat, identical seats, etc.) only one "H" point and one "actual torso angle" shall be determined for each row of seats, the 3-D H machine described in Annex HA being seated in a place regarded as representative for the row. This place shall be:
- H-4.16.1. in the case of the front row, the driver's seat;
 - H-4.16.2. in the case of the rear row or rows, an outer seat.

ANNEX HA

(See H-2.2)

DESCRIPTION OF THE THREE DIMENSIONAL "H" POINT MACHINE ^{*/} (3-D H machine)

HA-1. Back and seat pans

The back and seat pans are constructed of reinforced plastic and metal; they simulate the human torso and thigh and are mechanically hinged at the "H" point. A quadrant is fastened to the probe hinged at the "H" point to measure the actual torso angle. An adjustable thigh bar, attached to the seat pan, establishes the thigh centreline and serves as a baseline for the hip angle quadrant.

HA-2. Body and leg elements

Lower leg segments are connected to the seat pan assembly at the T-bar joining the knees, which is a lateral extension of the adjustable thigh bar. Quadrants are incorporated in the lower leg segments to measure knee angles. Shoe and foot assemblies are calibrated to measure the foot angle. Two spirit levels orient the device in space. Body element weights are placed at the corresponding centres of gravity to provide seat penetration equivalent to a 76 kg male. All joints of the 3-D H machine should be checked for free movement without encountering noticeable friction.

(* /For details of the construction of the 3-D H machine refer to Society of Automotive Engineers (SAE), 400 Commonwealth Drive, Warrendale, Pennsylvania/15096, United States of America. The machine corresponds to that described in ISO Standard 6549-1980.)

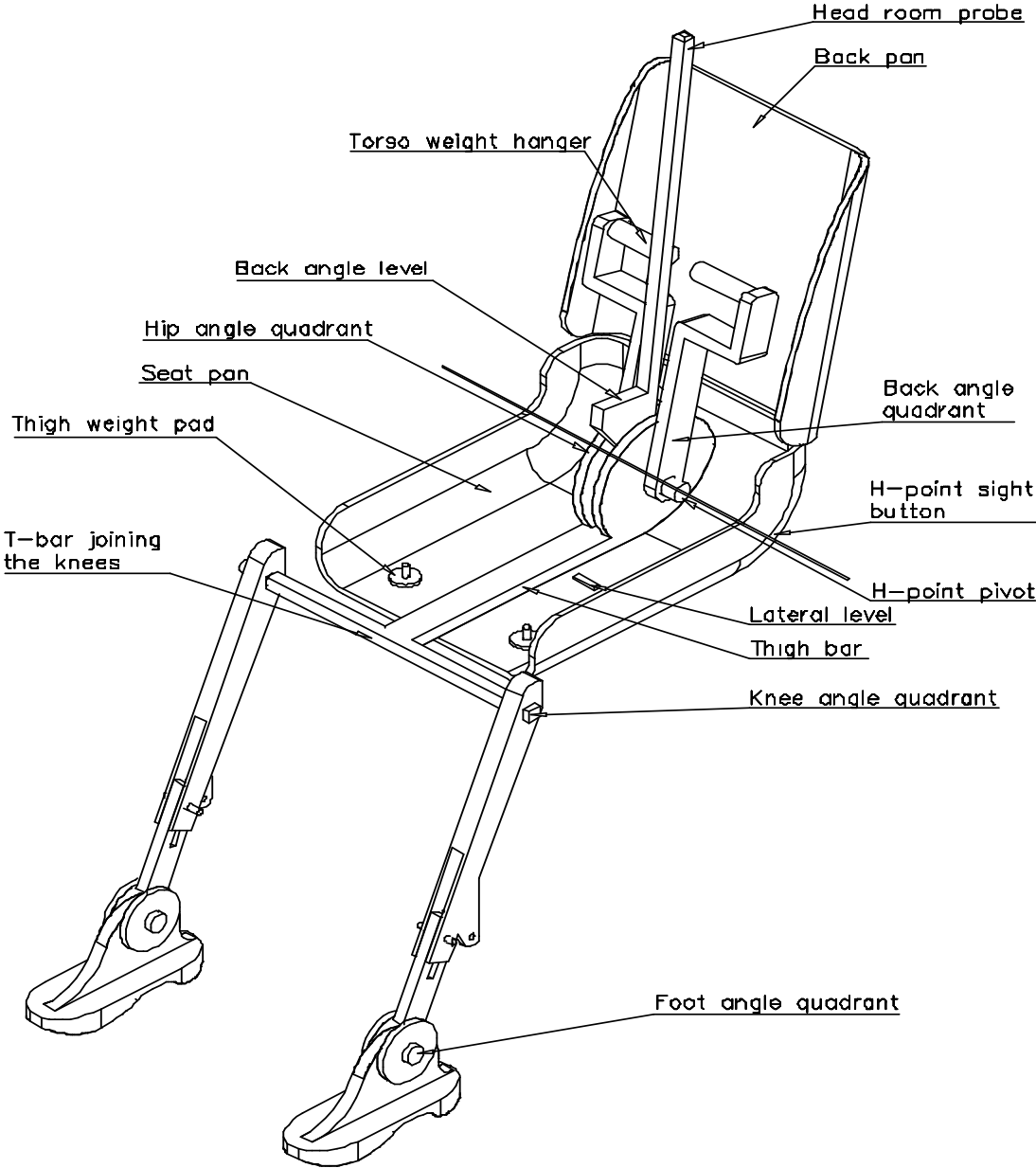

Figure HA-1
3-D H machine elements designation

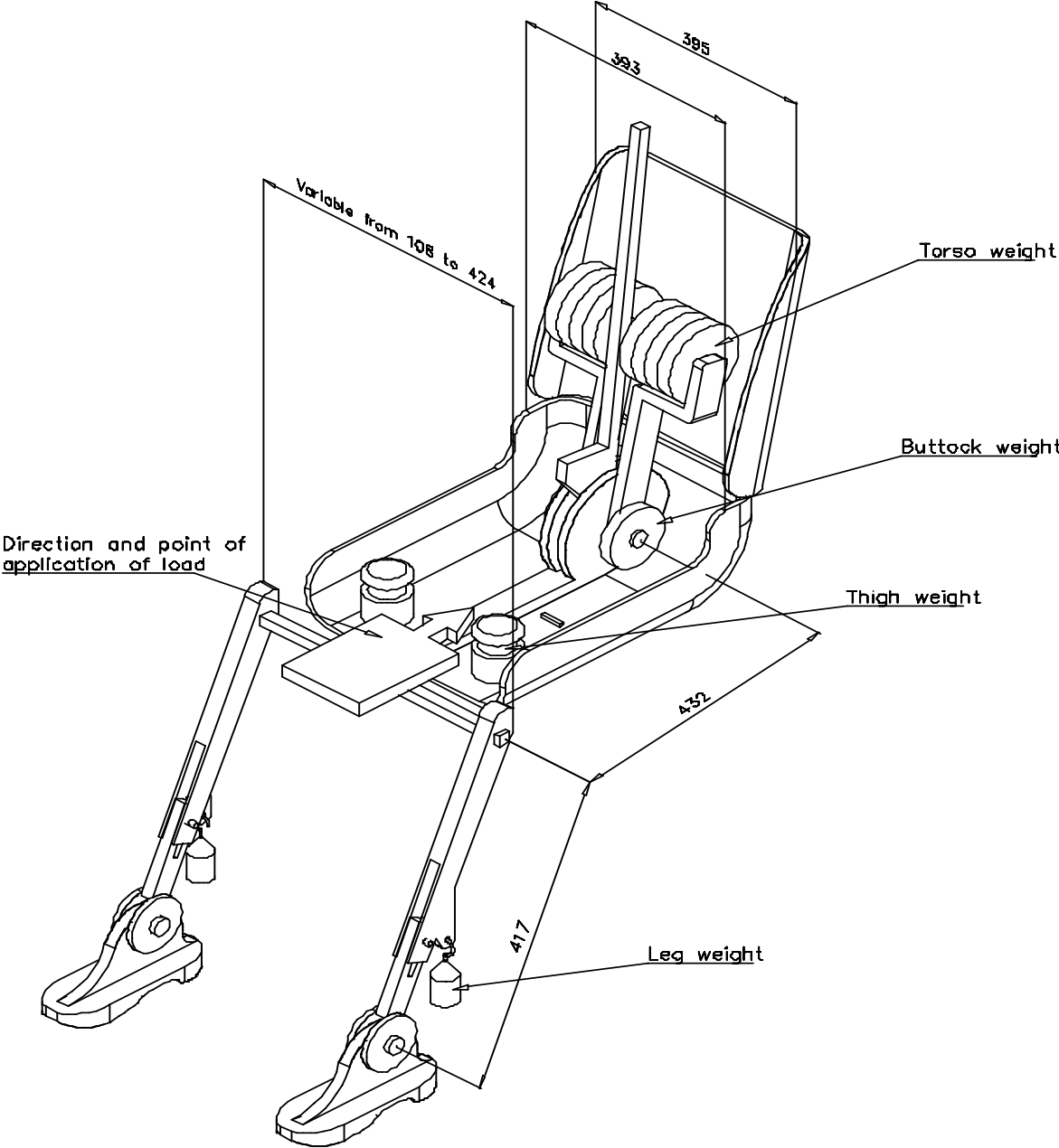

Figure HA-2

Dimensions of the 3-D H machine elements and load distribution

ANNEX HB
(See H-2.9)

THREE-DIMENSIONAL REFERENCE SYSTEM

- HB-1. The three-dimensional reference system is defined by three orthogonal planes established by the vehicle manufacturer (see Figure HB-1 ^{*/})
- HB-2. The vehicle measuring attitude is established by positioning the vehicle on the supporting surface such that the co-ordinates of the fiducial marks correspond to the values indicated by the manufacturer.
- HB-3. The co-ordinates of the "R" point and the "H" point are established in relation to the fiducial marks defined by the vehicle manufacturer.

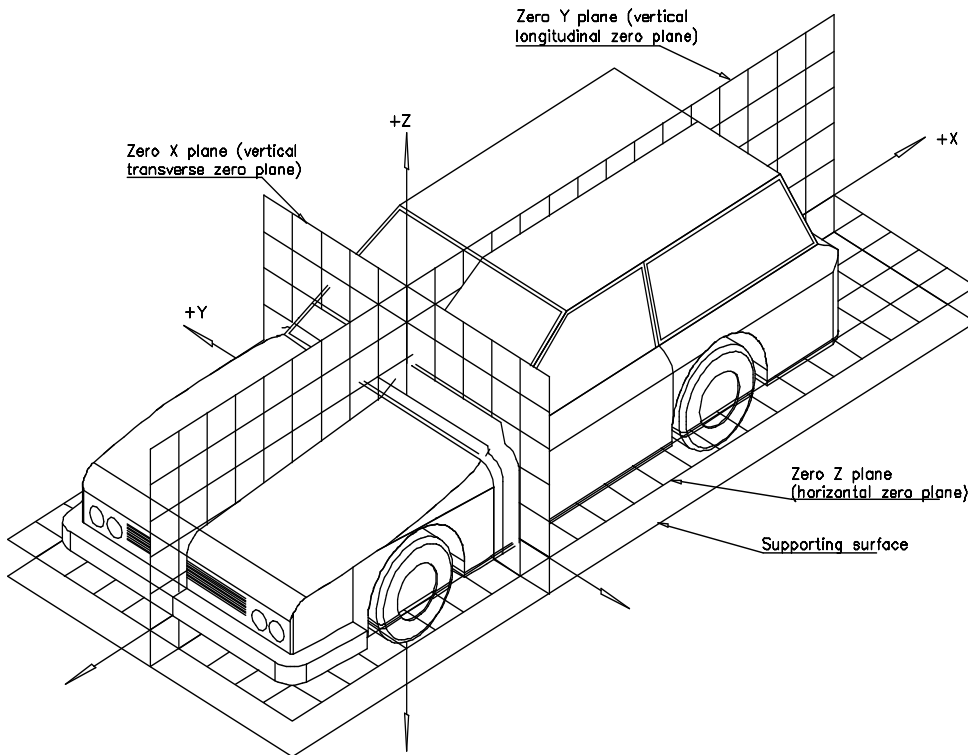

Figure HB-1
Three-dimensional reference system

^{*/} The reference system corresponds to ISO standard 4130, 1978

ANNEX HC

(See H-3.1)

REFERENCE DATA CONCERNING SEATING POSITIONS

HC-1. Coding of reference data

Reference data are listed consecutively for each seating position. Seating positions are identified by a two-digit code. The first digit is an Arabic numeral and designates the row of seats, counting from the front to the rear of the vehicle. The second digit is a capital letter which designates the location of the seating position in a row, as viewed in the direction of forward motion of the vehicle; the following letters shall be used:

- L = left
- C = centre
- R = right

HC-2. Description of vehicle measuring attitude

HC-2.1. Co-ordinates of fiducial marks

- X
- Y
- Z

HC-3. List of reference data

HC-3.1. Seating position:

HC-3.1.1. Co-ordinates of "R" point

- X
- Y
- Z.....

HC-3.1.2. Design torso angle

HC-3.1.3. Specifications for seat adjustment (Strike out what does not apply.)

- horizontal:
- vertical:
- angular:
- torso angle:

Note : List reference data for further seating positions under HC-3.2, HC-3.3, etc.

ANNEX J
(Reserved)

ANNEX K
(See 15.3.3.)

**CALCULATION OF THE DETECTION DISTANCE FOR
CMS OF CLASSES V AND VI**

K-1. CAMERA MONITOR DEVICE FOR INDIRECT VISION

K-1.1. Determination of the smallest discernable detail

The smallest discernable detail of the naked eye shall be defined according to standard ophthalmologic tests like the Landolt C test or the Triangle Orientation Discrimination (TOD) test. The smallest discernable detail at the centre of the viewing system can be determined using the Landolt C test or the TOD test. In the rest of the viewing area the smallest discernable detail may be estimated from the centrally determined smallest discernable detail and the local image deformation. For instance, in the case of a digital camera the smallest discernable detail at a given pixel location (in the monitor) scales inversely with the solid angle of the pixel.

K-1.1.1. Landolt-C test

In the Landolt-C test, test symbols are judged by the subject under test. In accordance with this test the smallest discernable detail is defined as the visual angle of the gap size of the Landolt C symbol at threshold size and is expressed in arcmin. The threshold size corresponds to the size at which the subject judges the orientation correctly in 75 per cent of the trials. The smallest discernable detail is determined in a test involving a human observer. A test chart containing test symbols is placed in front of the camera and the observer judges the orientation of test symbols from the monitor. From the threshold gap size of the Landolt C test symbol d [m] and the distance between the test pattern and the camera D [m] the smallest discernable details ω_c [arcmin] is calculated as follows:

$$\omega_c = \frac{d}{D} \cdot \frac{180.60}{\pi}$$

K-1.1.2 TOD test

The Landolt C test can be used to determine the smallest discernable detail of the camera-monitor system. However, for sensor systems it is more suitable to use the TOD (Triangle Orientation Discrimination) method which is similar to the Landolt C method, but involves equilateral triangular test patterns. The Triangle Orientation Discrimination method is described in detail by Bijl & Valetton (1999), who provide practical guidelines on how to perform a TOD measurement. In the method, triangular test patterns (see Figure 1) are viewed through the viewing system under test. Each triangle can have one out of four possible orientations (apex up, left, right or down) and

the observer indicates/guesses for each triangle its orientation. When this procedure is repeated for many (randomly oriented) triangles of different sizes the fraction of correct responses can be plotted (see Figure 2), and increases with test pattern size. The threshold is defined as the point at which the fraction correct crosses the 0.75 level and can be obtained by fitting a smooth function through the data (see Bijl & Valeton, 1999). Critical perception is reached when the critical object diameter equals two times the width of the triangle at threshold size. The smallest discernable detail ω_c is equal to 0.25 times the width of the triangle at threshold size. This means that, from the threshold triangle width w [m] and the distance between test pattern and the camera d [m] the smallest discernable detail ω_c [arcmin] is calculated as follows:

$$\omega_c = \frac{w}{4.D} \cdot \frac{180.60}{\pi}$$

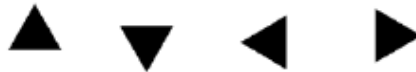

FIGURE 1
TRIANGULAR TEST PATTERNS USED IN THE TRIANGLE
ORIENTATION DISCRIMINATION (TOD) METHOD

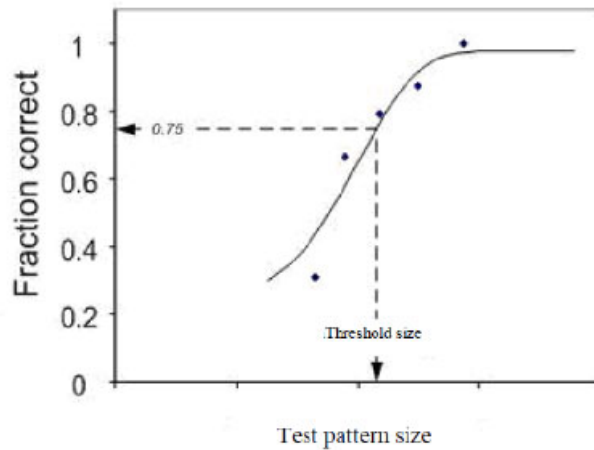

FIGURE 2
TYPICAL RELATIONSHIP BETWEEN THE SIZE OF THE TRIANGLE
AND THE FRACTION OF CORRECT RESPONSES.

For a monitor having certain dimensions and properties, a distance to the monitor shall be calculated within which the detection distance is dependent only on the performances of the camera. This critical viewing distance $r_{m,c}$ is defined by:

K-1.2. Determination of the critical viewing distance of the monitor

For a monitor having certain dimensions and properties, a distance to the monitor shall be calculated within which the detection distance is dependent only on the performances of the camera. The critical viewing distance r_{mcrit} is defined as the distance at which the smallest discernable detail displayed on the monitor spans 1 arcmin measured from the eye (the acuity threshold of a standard observer):

$$r_{\text{mcrit}} = \frac{\delta \cdot 60 \cdot 180}{\pi}$$

Where:

r_{mcrit} : critical viewing distance of the monitor [m]

δ : size of the smallest discernable detail on the monitor [m]

K-1.3 Determination of the detection distance

K-1.3.1. Maximum detection distance within the critical viewing distance where, due to the installation, the distance eye-monitor is less than the critical viewing distance, the maximum attainable detection distance shall be defined by

$$r_{\text{dclose}} = \frac{D_0 \cdot 60 \cdot 180}{\omega_c \cdot \pi \cdot f}$$

Where:

r_{dclose} detection distance [m]

D_0 : diameter of the critical object [m] according to paragraph 2.1.2.6. of this standard; for the calculation of r_{dclose} for Class V and VI devices, a representative value of 0.30 m shall be used

f : threshold increasing factor, which is equal to 8

ω_c : smallest discernable detail [arcmin]

K-1.3.2. Detection distance greater than the critical viewing distance. Where, due to the installation, the distance eye-monitor is more than the critical viewing distance, the maximum obtainable detection distance shall be defined:

$$r_{\text{dfar}} = \frac{r_{\text{mcrit}}}{r_m} \cdot r_{\text{dclose}}$$

Where:

r_{dfar} : detection distance for distances larger than the critical viewing distance [m]

r_{dclose} : detection distance for distances smaller than the critical viewing distance [m]

r_m : viewing distance, i.e. distance between eye and monitor [m]

r_{mcrit} : critical viewing distance [m]

K-2. SECONDARY FUNCTIONAL REQUIREMENTS

Based on the installation conditions, a determination shall be made to discover whether the entire device still satisfies the functional requirements listed in clause 6.2.2 of AIS-001 (Part 1) (Rev. 2), specifically the glare correction, the maximum and the minimum luminance of the monitor. It shall also be determined the degree to which the glare correction will be addressed and the angle at which sunlight can strike a monitor and these shall be compared to the corresponding measuring results from the system measurements. This may be either based on a CAD-generated model, a determination of the angles of light for the device when mounted on the relevant vehicle, or by carrying out relevant measurements on the relevant vehicle as described in clause 6.2.2.2 of AIS-001 (Part 1) (Rev. 2).

ANNEX L

**DETERMINATION OF THE DISPLAYED OBJECT SIZE
FOR CMS OF CLASSES V AND VI**

1. CAMERA MONITOR DEVICE FOR INDIRECT VISION**1.1. GENERAL**

Determination of the displayed object size considers the possible appearance of smear. The impact on the monitors image and consequence is the occultation of the Field of view and therefore of the object. The following differentiation is made:

1.2. CASE A: SMEAR APPEARS

1.2.1 Step 1: Under the condition described in clause 6.2.2.2.1.2. of this Regulation, measure the width (s) of the vertical bar displayed on the monitor e.g. with a measurement microscope

1.2.2 Step 2: Place the object at a defined distance from the camera. Measure the width of the object displayed on the monitor (b) in a situation without real sun light condition e.g. with a measurement microscope.

1.2.3 Step 3: Calculate the residual object width (α) according to the following equation:

$$\alpha [^\circ] = 60 \times 2 \times \arctan \frac{b-s}{2 \times r}$$

Where:

α : residual width of the object displayed on the monitor (with smear) [minutes of arc]

b: width of the object displayed on the monitor (without smear) [mm]

s: width of the smear [mm]

r: viewing distance [mm]

1.3. CASE B: SMEAR DOES NOT APPEAR

1.3.1 Step 1: Place the object at a defined distance from the camera. Measure the width of the object displayed on the monitor (b) in a situation without real sun light condition e.g. with a measurement microscope.

1.3.2 Step 2: Calculate the object width (α) according to the following equation:

$$\alpha [^\circ] = 60 \times 2 \times \arctan \frac{b}{2 \times r}$$

Where:

- (a) width of the object displayed on the monitor (without smear) [minutes of arc]
- (b) width of the object displayed on the monitor (without smear) [mm]
- (r) viewing distance [mm].

1.4 DATA SUPPLIED BY THE INSTRUCTIONS FOR USE

In the case of Classes V and VI camera monitor devices the instructions for use shall include a table that shows the minimum and maximum mounting height of the camera above ground under consideration of different viewing distances. The camera shall be mounted within the applicable height range. The viewing distances shall be selected from the intended context of use. The following table shows an example.

Viewing distance	0.5m	1 m	1.5 m	2.0 m	2.5 m
Minimum mounting height	Para. 1.4.1.	Para. 1.4.1.	Para. 1.4.1	Para. 1.4.1.	Para. 1.4.1.
Maximum mounting height	Para. 1.4.2.	Para. 1.4.2.	Para. 1.4.2.	Para. 1.4.2.	Para. 1.4.2.

- 1.4.1. The value of the minimum mounting height is the same for all viewing distances as it is independent of the viewing distance. It is determined by the dimensions of the field of vision and the field of view of the camera. Use the following working steps for determination of the minimum mounting height.
 - 1.4.1.1. Step 1: Draw the intended field of vision on ground.
 - 1.4.1.2. Step 2: Place the camera above the field of vision in such a way that the camera is viewing the field of vision. The lateral position shall be in accordance with the intended mounting position at the vehicle.
 - 1.4.1.3. Step 3: Change the height of the camera above ground in such a way, that the field of vision displayed on the monitor covers an area at least as large as the field of vision. Furthermore, the field of vision display shall encompass the entire monitor screen
 - 1.4.1.4. Step 4: Measure the height between camera and ground which is the minimum mounting height. Report the result value.
- 1.4.2. The value of the maximum mounting height is different for different viewing distances as the displayed object size varies with the mounting height. Use the following working steps for determination of the maximum mounting height:

- 1.4.2.1 Step 1: Determine the minimum width b_{\min} of the critical object displayed on the monitor for each viewing distance.

$$b_{\min} = 2 \times r \times \tan \frac{8'}{2 \times 60}$$

Where:

r: viewing distance [mm]

b_{\min} : minimum width of the critical object displayed on the monitor [mm].

- 1.4.2.2 Step 2: Place the critical object inside the drawn intended field of vision in a position at which the distance between the critical object and the camera is largest. The illumination conditions shall be in such a way that the critical object is clearly visible on the monitor.

- 1.4.2.3. Step 3: Select the first value of the possible viewing distances.

- 1.4.2.4. Step 4: Change the height of the camera above ground in such a way, that the residual width B of the object displayed on the monitor is equal to the minimum width allocated to that viewing distance.

$$B = b_{\min}$$

Where:

B: residual width of the object displayed on the monitor (which is "b" in cases without smear and "b – s" in cases with smear) in mm (see clause 1.1. General)

- 1.4.2.5. Step 5: Measure the height between camera and ground which is the maximum mounting height allocated to that viewing distance. Report the result value.

- 1.4.2.6 Step 6: Repeat the aforementioned steps 4 and 5 for the other viewing distances.

ANNEX M

TEST METHODS AND SAFETY PROVISIONS FOR
CMS OF CLASSES I TO IV

1. TEST METHODS

1.1. GENERAL SPECIFICATIONS

The Testing agency shall use recognized test methods to check compliance with the requirements defined above in the standard.

1.2. FLICKER TEST

The entire image area of the monitor shall be free of flicker for at least 90 per cent of the user population. The flicker evaluation uses the determination given in Annex B of ISO13406-2: 2001. The following measurement procedure applies:

- 1.2.1. Position the camera of the CMS in front of a still scene (e.g. chessboard chart). Use a scene illumination of about 500 lx. Measure the time resolved luminance value of a portion of the monitor that displays a white patch of the chessboard chart. The measurement location shall be near the centre of the monitor defined size and the measurement direction is perpendicular onto the monitor. Perform a Fourier transform of the luminance-time function for determination of the amount of energy E_{obs} at various frequencies up to 120 Hz. These numbers are then compared to the amounts of energies that people will detect as flicker, the predicted flicker threshold E_{pred} .

If $E_{obs} < E_{pred}$ at every frequency < 120 Hz then it is likely that people will not see flicker.

If $E_{obs} \geq E_{pred}$ at any frequency < 120 Hz then it is likely that people will see flicker.

- 1.2.2. Determination of E_{obs} , which is the observed energy at every frequency < 120 Hz:

$$E_{obs,n} = DC * AMP_n = A * c_0 * AMP_n = b_0 * L_t^{b_1} * c_0 * AMP_n$$

where:

$$b_0 = 12.45184$$

$$b_1 = -0.16032$$

For L_t , which is the adaption luminance:

Use $L_t = L_{monitor/chart/white/ambient}$ from ISO 16505:2015 (subclause 7.8.2:

Test 2: Day condition with diffuse sky-light exposure).

For c_0 , which is the zero Fourier coefficient, and is the dark-room luminance averaged over time.

Use $c_0 = L_{\text{monitor/chart/white}}$ from ISO 16505:2015

(see ISO 16505:2015, subclause 7.8.2.: Test 2: Day condition with diffuse sky-light exposure with the diffuse light source switched off).

For AMP_n :

$$AMP_n = \frac{2 * |c_n|}{c_0}$$

For c_n , which is the nth Fourier coefficient. Take the nth Fourier coefficient from the Fourier transform.

- 1.2.3. Determination of E_{pred} , which is the predicted energy at every frequency < 120 Hz:

$$E_{\text{pred},n} = a * e^{b * f_n}$$

The variables a and b depend on the monitor diagonal as seen from the driver's ocular reference point and is measured in degree (see TableB.1 in the standard ISO 13406-2:2001). For a monitor diagonal a monitor/Diagonal of less than 20°, variables a and b equals to $a = 0.1276$ and $b = 0.1424$.

The monitor diagonal a monitor/Diagonal is given by the following equation:

$$\alpha_{\text{monitor/Diagonal}} = 2 * \arctan \frac{\text{Diagonal}}{2 * a_{\text{monitor/D}}}$$

Where:

Diagonal diagonal of the monitor, measured in metres

$a_{\text{monitor/D}}$ Distance of the ORP to the centre of the monitor coordinate system.

- 1.2.4. For every frequency < 120 Hz compare the observed energy E_{obs} with the predicted energy E_{pred} and report the result value for passed or failed.

1.3. POINT LIGHT SOURCES TEST METHOD

Figure 1 shows the test arrangement for the point light source test.

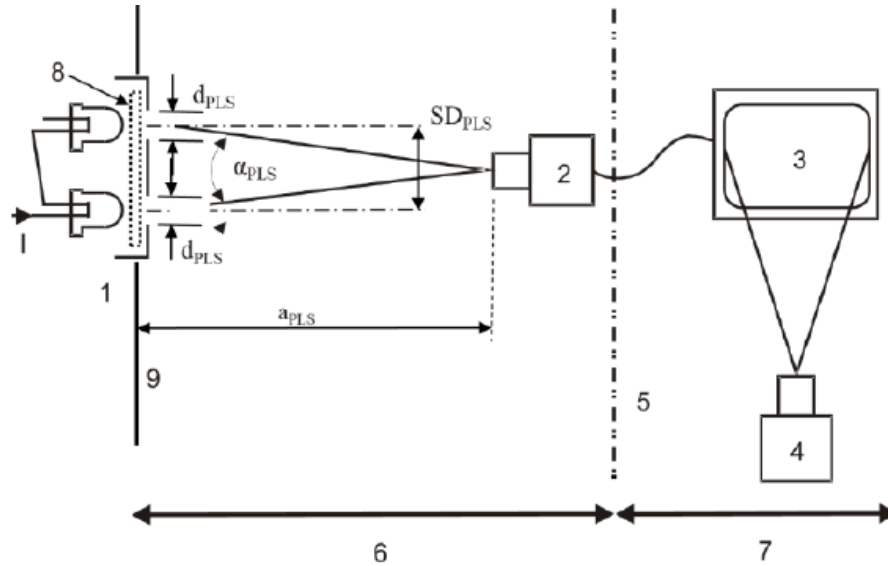

1.	Point light source lab model to emulate passing beam headlamp at 250 m
2.	Camera being tested
3.	Monitor being tested
4.	Reference camera
5.	Optical or spatial isolation between camera and monitor display environment
6.	Camera-side dark environment
7.	Monitor-side dark room environment
8.	LED light diffuser/aligner, according to necessity
9.	Neutral black background
	Figure 1 - Test arrangement for the point light source test
	<p>The point light source lab model is an emulation of a set of vehicles passing beam headlamps at a distance of 250 m with luminous intensity of 1,750 cd, in accordance to the maximum allowance of luminous intensity of a vehicle passing-beam headlamp at point "BR" described in AIS-010 (Part 1) (Rev.1):2010 amended time to time. The test is performed considering a set of lamps with 0.09 m diameter and separated by 1.3m. This results in a luminance of 275,000 cd/m². For laboratory evaluation purposes the light sources shall be adjusted to have a luminance within the range of 250,000 to 300,000 cd/m² by using a constant current source.</p> <p>For laboratory evaluation purpose a shorter distance than 250 m can be used.</p> <p>The distance a_{PLS} from the camera entrance pupil to the point light</p>

	<p>source lab model shall be within the depth of field of the camera. The point light source lab model shall be adjusted to the measuring distance aPLS in terms of lamp size dPLS and distance SDPLS. The value for dPLS and SDPLS shall be rounded to the nearest 0.1 mm.</p> <p>A typical white LED having a correlated colour temperature of 6,500 K with a tolerance of $\pm 1,500$ K is used for this evaluation. The emitting surface of the LED shall keep an even luminance or it shall be diffused using an optional diffuser as shown in Figure 1.</p> <p>The angular size corresponding to the headlamp of 0.09 m diameter and the angular orientation of the two point light source separated by 1.3m of each other, at 250 m distance, are calculated as:</p>
	$\alpha_{LampDia} = 2 \times \arctan \frac{(0.09 / 2)}{250} = 2 \times \arctan \frac{(d_{PLS} / 2)}{a_{PLS}} = 1.24'$ <p>and</p> $\alpha_{PLS} = 2 \times \arctan \frac{(1.3 / 2)}{250} = 2 \times \arctan \frac{(SD_{PLS} / 2)}{a_{PLS}} = 17.9'$
	<p>For example, at 6 m distance from CMS to this emulated LED, the corresponding aperture opening of the LED shall be dPLS = 2.2 mm in diameter and separated by SDPLS = 31.2 mm to emulate the set of passing beam headlamps located 250 m from the CMS.</p> <p>Ambient illumination at the point light source lab model and at the monitor-side shall be less than 2 lx.</p> <p>The luminance of the LED shall be measured at the same angular direction of the CMS to confirm that light emitted from the aperture delivers the correct luminance.</p> <p>The luminance of the rendered point light sources on the monitor is measured by using a reference (luminance) camera according to ISO16505:2015 providing a sufficient spatial resolution, or equivalent.</p> <p>For the evaluation, the CMS shall be switched to the operation mode intended to observe the point light sources.</p> <p>Position the camera of the CMS such that its optical axis is aligned to the perpendicular orientation of the point light source lab model (Figure1). Target the CMS camera to display the point light sources in the middle of the monitor defined size. The distance from the camera entrance pupil to the point light source lab model shall be set to aPLS.</p> <p>For determination of the point light source detection factor PLSDF evaluate the luminance profile in horizontal and vertical direction (Figure 2).</p>

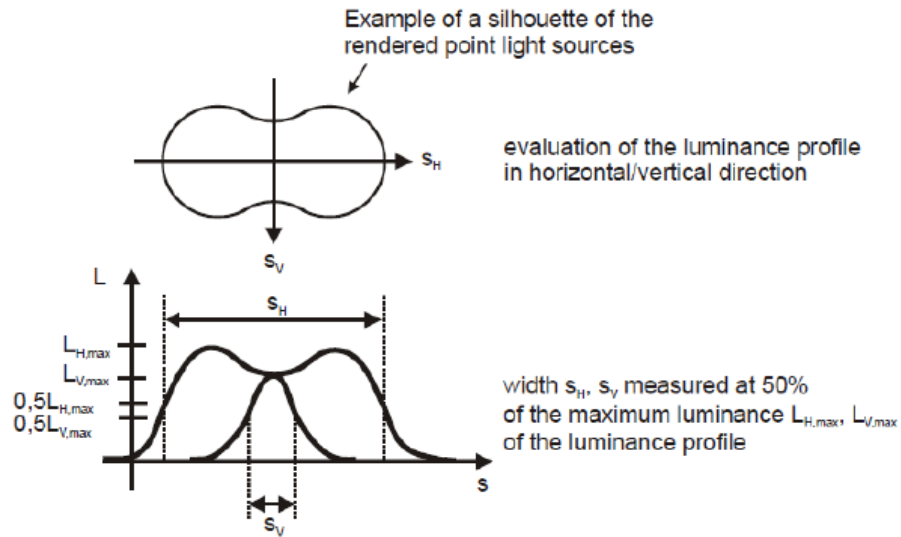

Figure 2
Luminance profile of the rendered point light sources for the determination of PLSDF

The point light source detection factor - PLSDF is determined by the following equation:

$$PLSDF = \frac{s_H \times L_{H,max}}{s_V \times L_{V,max}}$$

Where:

s_H full width at half maximum of the luminance profile in horizontal direction at the vertical centre

L_{H,max} maximum luminance of the luminance profile in horizontal direction at the vertical centre

s_V full width at half maximum of the luminance profile in vertical direction at hourglass point

L_{V,max} maximum luminance of the luminance profile in vertical direction at hourglass point

Verify the consistency of the result with slightly shifted position of the point light source lab model.

For determination of the point light source contrast factor PLSCF, evaluate the luminance profile in horizontal direction (Figure 3) at the vertical centre.

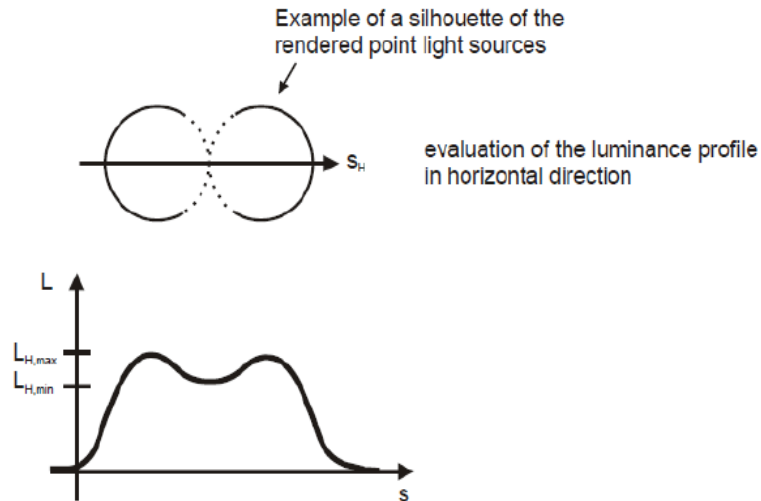

Figure 3
Luminance profile of the rendered point light sources for the determination of the PLSCF

The point light source contrast factor PLSCF is determined by the following equation:

$$PLSCF = \left(1 - \frac{L_{H,\min}}{L_{H,\max}} \right)$$

Where:

$L_{H,\max}$ maximum luminance of the luminance profile in horizontal direction

$L_{H,\min}$ luminance value at saddle point of the luminance profile, which is equivalent to the minimum luminance value between the two luminance peaks (see Figure 3)

Verify the consistency of the result with slightly shifted position of the point light source lab model.

1.4. GREY SCALE RENDERING TEST METHOD

The grey scale rendering test shall verify that CMS are capable of displaying at least 8 tonal grey steps distinguishable within the darkest and brightest output range from the reproduced chart on the CMS monitor. The grey scale rendering test is evaluated using a 20:1 low contrast grey scale chart as described in ISO 14524:2009, Table A.1, under 500 lx illuminated scene environment.

The distinguishable tonal difference described herein is defined as an display output signal whose lightness difference between two different tonal input through the CMS satisfy at least $\Delta L^* \geq 3.0$, with L^* defined as lightness according to the definition in CIE 1976 $L^*a^*b^*$ colour space.

Figure 4 shows the test arrangement for the grey scale rendering test.

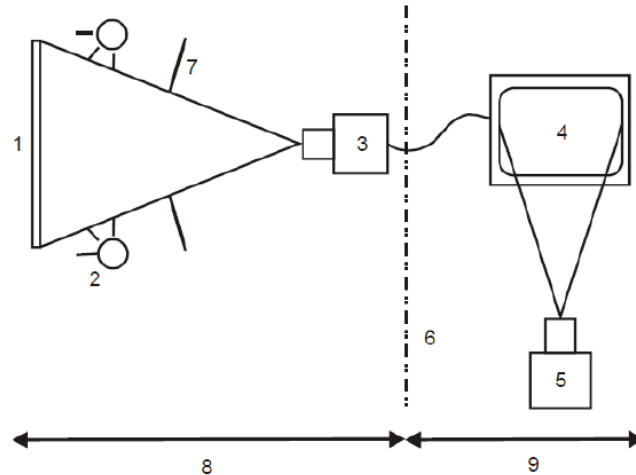

1.	Test chart (grey scale rendering chart)
2.	Illumination for test chart
3.	Camera being tested
4.	Monitor being tested
5.	Reference camera
6.	Optical or spatial isolation between camera and monitor display environment
7.	Optical isolation barrier to avoid direct light into lens
8.	Camera-side
9.	Monitor-side
Figure 4 - Test arrangement for the grey scale rendering test	

Figure 5 shows an example of a grey scale rendering chart to be used in this measurement. The grey scale rendering chart shall consist of 12 different tonal density grey patches.

The density value D_i shall follow the values as defined by ISO 14524:2009 Table A.1 for low contrast 20:1. The definition of D_i is given in the ISO 14524:2009.

The background of the patches shall be covered with a neutral grey colour having a density value D_i of 0.54 ± 0.05 .

Both reflective and transmissive charts with Lambertian characteristics can be used.

The whole camera image area shall be covered by the chart image. The grey scale rendering chart shall be placed in such a way so that the grey patches are visible in the centre of the monitor defined size.

Adjust the distance between the camera under test and the test chart to have individual patches of the chart displayed by at least 50 x 50 pixels on the monitor under test, whenever possible. For Class IV devices exhibiting high distortion and/or optical vignetting, a reduced size area

may also be used to minimize the vignette effect on the measurement results.

The illumination shall be similar to the CIE D65 standard illuminant and have a correlated colour temperature of $T = 6,500 \text{ K}$ with a tolerance of $\pm 1,500 \text{ K}$.

The test is performed with a scene illumination of 500 lx (this test condition is equivalent to test condition for colour rendering as defined in ISO 16505:2015 clause 7.8.3), and at room temperature $22 \text{ }^\circ\text{C} \pm 5 \text{ }^\circ\text{C}$. Ambient illumination at the monitor-side shall be $\leq 10 \text{ lx}$, and glare light source to the monitor shall be avoided.

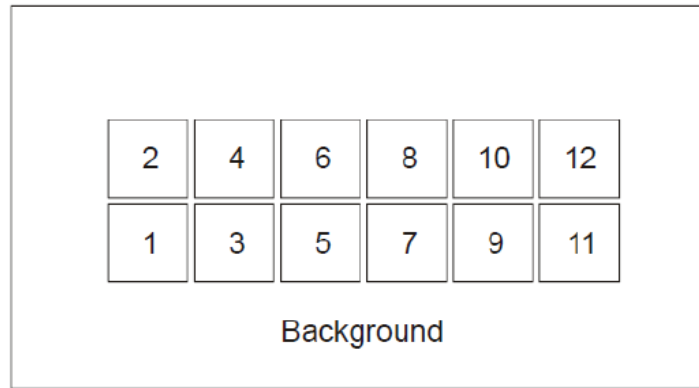

Figure 5 - Example of the grey scale rendering chart

Each patch on the grey scale rendering chart shall have a size of $50 \times 50 \text{ mm}$. The distance between the patches shall be 5 mm .

Table 1 shows density value D_i of the 12 different grey patches as well D_i of the background.

Grey patch No.	Density D_i
1	1.40
2	1.21
3	1.05
4	0.90
5	0.77
6	0.65
7	0.54
8	0.44
9	0.35
10	0.26
11	0.18
12	0.10
Background	0.54 ± 0.05

Table 1: Density values D_i

Measure the luminance Y_i of each grey patch $i = 1 \dots 12$ by using the reference camera. Then, calculate the lightness of each grey patch:

$$L_i^* = 116 \times \left(\frac{Y_i}{Y_{12}} \right)^{1/3} - 16, \text{ when } Y_i/Y_{12} > 0.008856$$

$$L_i^* = 903,3 \times \left(\frac{Y_i}{Y_{12}} \right), \text{ when } Y_i/Y_{12} \leq 0.008856$$

Calculate the lightness difference between each grey patch:

$$\Delta L^* = L_{i+1}^* - L_i^*$$

and compare the result with the requirement.

- 2 Special requirements to be applied to the safety aspects of camera monitor systems for indirect vision

2.1. GENERAL

The purpose of this clause is to specify the requirements for documentation and verification for CMS for indirect vision of Classes I to IV to replace mandatory rear-view mirrors for road vehicles.

"The System", referred to herein, is the one for which type approval is being sought.

This clause 2. does not specify the performance criteria for "The System" but covers the methodology applied to the design process and the information which shall be disclosed to the testing agency, for type approval purposes.

This information shall show that "The System" respects, under normal and fault conditions, all the appropriate performance requirements specified elsewhere in this standard.

2.2. DEFINITIONS

2.2.1. Camera Monitor System (CMS)

A CMS is used in road vehicles to present the required outside information of a specific field of view to the driver. It replaces a conventional legally prescribed mirror system on the vehicle by means of electronic image capture and display systems.

It consists of a camera that is usually installed at the bodywork of a vehicle and a monitor that is usually placed inside the vehicle.

2.2.2 Camera

A camera is a device to capture colour images of a specific field of view. It mainly consists of two relevant items: imager and lens.

2.2.3. Monitor

A monitor is a device for displaying images. It either consists of a matrix of active areas that radiate light of different wavelengths or is a (usually diffuse) reflector that is illuminated in different wavelengths and in a matrix of specific points by a projector

2.2.4 Control unit

A control unit is a component which controls communication and coordination between electronic components, e.g., a camera and a monitor.

2.2.5. Safety concept

A safety concept is a description of the measures designed into the system, for example within the electronic units, so as to address system integrity and thereby ensure safe operation even in the event of a system or electrical failure.

2.2.6. "Boundary of functional operation"

"Boundary of functional operation" defines the boundaries of the external physical limits within which the system is able to maintain functionality.

2.3. DOCUMENTATION

2.3.1. The vehicle manufacturer shall provide the following documentation:

- (a) A description of the camera monitor system which gives an explanation of the main function of the system, incl. drawings, pictures, block diagrams, etc.
- (b) A description of the location of the camera and the monitor in the vehicle (system overview).
- (c) Name of manufacturer of camera, monitor and electronic control units.
- (d) Type of camera and monitor. Each unit shall be clearly and unambiguously identifiable (e.g., by marking for hardware and marking or software output for software content) to provide corresponding hardware and documentation association.
- (e) Explanation of the warning strategy and the safety concept, as defined by the manufacturer, covering at least the list of failures of clause 2.4.

2.3.2. For periodic technical inspections, the documentation shall describe how the current operational status of "The System" can be verified.

2.3.3. The limits for the boundary of functional operation (e.g., environmental parameters) shall be stated where appropriate to the system performance.

2.3.4. Safety concept of the manufacturer

The manufacturer shall provide a statement which affirms that the strategy chosen allows a safe operation of "The System".
In the case of a failure, the driver shall be informed for example by a

clear and visible warning signal or message display. When the system is activated, the warning shall be present as long as the fault condition persists.

The fault conditions shall be established and maintained by the manufacturer and shall be made open for inspection by the Testing agency at the time of the type approval

2.3.5. The chosen analytical approach(es) shall be established and maintained by the manufacturer and shall be made open for inspection by the Testing agency at the time of the type approval.

2.4. LIST OF FAILURES

2.4.1 Camera

- (a) Failure of the camera.
- (b) Electronic noise, reduced detail resolution;
- (c) Defocus of the optics, reduced detail resolution.

2.4.2. Monitor

- (a) Failure of monitor display, no image content is displayed;
- (b) Freeze of displayed monitor content, image content is not refreshed;
- (c) Enlarged image formation time, changing image content is blurred.

2.4.3. Control unit

- (a) Failure of the control unit;
- (b) Failure in the communication between camera and control unit;
- (c) Failure in the communication between control unit and monitor.

2.5. VERIFICATION

2.5.1. Verification of the performance of the camera monitor system under no-fault and fault conditions shall be conducted against the manufacturer's specification.

2.5.2. The verification of the safety concept of the reaction of the camera monitor system shall, at the discretion of the Testing agency, be verified according to the influence of failures in clause 2.4. The verification results shall correspond with the documented summary of the failure analysis in clause 2.4., to a level of overall effect such that the safety concept and execution are confirmed as being adequate.

ANNEX N

(See 16.2.)

CRITERIA FOR EXTENSION OF APPROVAL

N 1 The table lists verifications to be carried out in case of changes in the parameters declared at the time of submitting for the earlier type approval.

These parameters are to be used for selecting a vehicle to represent a range of vehicles.

N 2 Changes other than those listed in the table are considered to have no adverse effect on the indirect vision

Table 1 Extension criteria for mirror		
1.	Name of the vehicle manufacturer	In case of different vehicle manufacturer, complete type approval to be carried out. In case of changes in the name of manufacturer or trademark for commercial reasons, type approval shall be extended without any testing.
2.	Address of the vehicle manufacturer	No additional tests or verification needed
3.	Address of plant(s) where vehicle is manufactured	No additional tests or verification needed
4.	Vehicle Type and general commercial description(s):	No additional verification needed
5.	Category of vehicle	If it affects the number of compulsory or prohibited mirrors as per 15.2.1.1.1 compliance to this clause and related fields of vision to be checked. However, if the mirrors fitted optionally on the approved type has become mandatory for new type, field of vision need not be re-verified, if they have been verified already during type approval.
6	Driving cab (forward control or bonneted) (only for N2 >7.5t and N3)	If changed to forward control, fitment and field of vision for class VI mirrors to be verified. If changed to bonneted type, no verification required.

7.	Range of vehicle dimensions (overall):	See Sr. No. 8.
8	Maximum bodywork width	Field of vision requirements to be verified if there is an increase in width. If decrease, no additional verification required.
9	Type of device (mirror to other devices or vice versa)	Affected vision requirements to be verified
10	Fitment of additional optional classes of mirrors	Applicable vision requirements of additional mirror to be verified.
11	Name of manufacturer of rear view mirrors used	If the location of mirror wrt. R point is not changed and/or, the dimensions of reflecting surface have not reduced, no verification required. Otherwise the applicable field of vision should be verified.
12	Change of position of mirror with respect to R point	All field of vision requirements to be verified.
13	Description of the electronic components (if any) of the adjustment device	No additional verification needed.
14	Optional equipment which may affect the rearward field of vision:	Affected field of vision requirements to be verified.
15	Devices for indirect vision other than mirrors:	
15.1	Name of manufacturer of devices used	If the location of the sensing device is not changed, no verification required. Otherwise the applicable field of vision should be verified.
16.	Radius of curvature	If increase, field of vision to be checked.

ANNEX P
(See introduction)

**COMPOSITION OF AISC PANEL ON
REAR VIEW MIRRORS***

Panel Convener	
Mr. P. S. Gowrishankar	SIAM (Tata Motors Ltd.)
Members	Representing
Dr. B. V. Shamsundara	The Automotive Research Association of India
Ms. Sonali Tambolkar	The Automotive Research Association of India
Mr. Vishal P. Rawal	The Automotive Research Association of India
Mr. Ankit Sinha	The Automotive Research Association of India
Ms. Shubhangi Dalvi	Central Institute of Road Transport
Ms. Vijayanta Ahuja	International Centre for Automotive Technology
Mr. Rohit Yadav	International Centre for Automotive Technology
Mr. Ravi M	Global Automotive Research Centre
Mr. S. Nagarajan	Global Automotive Research Centre
Mr. Karthikeyan. K	Global Automotive Research Centre
Mr. Ved Prakash Gautam	SIAM (Ashok Leyland Ltd.)
Mr. V. Faustino	SIAM (Ashok Leyland Ltd.)
Mr. D. Karthikeyan,	SIAM (Daimler India Com. Veh. Pvt., Ltd.)
Mr. Manikandan Rama	SIAM (Daimler India Com. Veh. Pvt., Ltd.)
Mr. Navneet Kaushik	SIAM (Honda 2 Wheeler)
Mr. Sudhir Sathe	SIAM (Mahindra & Mahindra Ltd.)
Ms. Pushpanjali Pathak	SIAM (Mahindra & Mahindra)
Mr. Shailesh Kulkarni	SIAM (Mahindra & Mahindra Ltd.)
Mr. Karuppasamy Thangaraj	SIAM (Mahindra & Mahindra Ltd.)
Mr. Tangri Devinder	SIAM (Mahindra & Mahindra Ltd.)
Mr. Abhijit Dhotre	SIAM (Mahindra & Mahindra Ltd.)
Mr. Devender	SIAM (Mahindra & Mahindra Ltd.)
Mr. Arun Kumar	SIAM (Maruti Suzuki India Ltd.)
Mr. Rajesh Kumar	SIAM (Maruti Suzuki India Ltd.)
Mr. Nitish Seth	SIAM (Maruti Suzuki India Ltd.)
Mr. Tarun Nagar	SIAM (Mercedes Benz India Ltd.)
Mr. Amit Patil	SIAM (Mahindra Truck & Bus Division)
Mr. Jebin Jowhar	SIAM (Renault Nissan)
Mr. Vivekraj S	SIAM (Renault Nissan)
Mr. Mohit Gupta	SIAM (SML Isuzu Ltd.)
Mr. Abhinav Sharma	SIAM (SML Isuzu Ltd.)

Mr. Pushpinder Singh	SIAM (SML Isuzu Ltd.)
Mr. Vishal Jain	SIAM (Isuzu Motors India)
Mr. M Raju	SIAM (Toyota Kirloskar Motor Private Limited)
Mr. Shekar M. B.	SIAM (Toyota Kirloskar Motor Private Limited)
Ms. Namrata Deb	SIAM (Tata Motors Ltd.)
Mr. Jagtap Milind	SIAM (Skoda Auto VW Ind. Pvt. Ltd.)
Mr. Pramodkumar Hugar	SIAM (Volvo Trucks India)
Mr. Rahul Jain	SIAM (VECV)
Mr. Sivaramakrishnan	SIAM (Ather Energy)
Ms. Aditi Nandanwar	SIAM (Ather Energy)
Mr. Philip Koshy	TMA (Sonalika Int. Tractors Ltd)
Mr. Mohit	TMA (Sonalika Int. Tractors Ltd)
Mr. Mansigh Jagadale	TMA (M/s John Deer)
Mr. Uday Harite	Automotive Component Manufacturers Association of India - ACMA
Mr. Arvind Arora	ACMA (Tata Ficoso)
Mr. Vinod Kumar Srivastava	ACMA (Fiem Industries Ltd.)
Mr. Gaurav Saini	Krishna Ishizaki Auto Ltd.
Mr. Gitesh Mutha	ACMA (UNO Minda)
Mr. Mohsin Hasan	Krishna Ishizaki Auto Ltd. (Lab).
Mr. Subrat Dash	Ola Electric
Mr. B. N. S, Mogallana	Sandhar Automotives
Mr. K. Velmurugan	Sandhar Automotives
Mr. Chandran	SMR-Chennai
Mr. Sidhartha Mitra	SMR-Chennai
Mr. Umashankar Gnanagurusamy	SMR-Chennai
Mr. Venkatasubramanian Saminathan	CREAT, Pune
Mr. Kishor Jadhao	CREAT, Pune

* At the time of approval of this Automotive Industry Standard (AIS)

ANNEX Q
(See introduction)

COMMITTEE COMPOSITION *
Automotive Industry Standards Committee

Chairperson	
Dr. Reji Mathai	Director, The Automotive Research Association of India
Members	Representing
Representative from	Ministry of Road Transport and Highways, New Delhi
Representative from	Ministry of Heavy Industries, New Delhi
Representative from	Office of the Development Commissioner, MSME, Ministry of Micro, Small and Medium Enterprises, New Delhi
Shri Shrikant R. Marathe	Former Chairman, AISC
Shri P. V. Srikanth	Bureau of Indian Standards
Director	Central Institute of Road Transport
Director	Global Automotive Research Centre
Director	International Centre for Automotive Technology
Director	Indian Institute of Petroleum
Director	Vehicles Research and Development Establishment
Director	Indian Rubber Manufacturers Research Association
Representatives from	Society of Indian Automobile Manufacturers
Representative from	Tractor Manufacturers Association
Representative from	Automotive Components Manufacturers Association of India
Representative from	Indian Construction Equipment Manufactures' Association (ICEMA)
Member Secretary	
Shri Vikram Tandon	The Automotive Research Association of India

* At the time of approval of this Automotive Industry Standard (AIS)