

Amendment No 3 (09/2022)

To

AIS-009

**Automotive Vehicles - Installation Requirements of Lighting and Light-Signalling
Devices for 2 and 3 Wheelers, their Trailers and
Semi-Trailers**

1.0 Page 8, clause 6.4.3,

Replace the existing text with the following

6.4.3 For the distance between the inner edges of the two apparent surfaces in the direction of the reference axes, there shall be no special requirement.

PRINTED BY

THE AUTOMOTIVE RESEARCH ASSOCIATION OF INDIA

P. B. NO. 832, PUNE 411 004

ON BEHALF OF

AUTOMOTIVE INDUSTRY STANDARDS COMMITTEE

UNDER

CENTRAL MOTOR VEHICLES RULES - TECHNICAL STANDING COMMITTEE

SET-UP BY

MINISTRY OF ROAD TRANSPORT & HIGHWAYS

(DEPARTMENT OF ROAD TRANSPORT & HIGHWAYS)

GOVERNMENT OF INDIA

23rd September 2022

Amendment No 2 (01/2020)

To

AIS-009 : 2001

Automotive Vehicles –Installation Requirements of Lighting and Light-Signalling Devices for L Category Vehicles, their Trailers and Semi-Trailers

1.0 Page 4/29, Clause No 4, in the table add a row at the end:

q)	Reflective Tape: (For E-Rickshaw & E-Cart implementation from 1 st April 2020 as per GSR 807(E) dated 23 rd Oct 2019)	Front: White Rear: Red	At the front: White Reflective tape of width not less than 20 mm At the rear: Red Reflective tape of width not less than 20 mm
----	---	---------------------------	---

2.0 Page 10/29, After Clause No 6.9, add new clauses 6.10 as follows:

6.10	Reflective Tape
6.10.1	Arrangement:
6.10.1.1	At the front: White Reflective tape of width not less than 20 mm conforming to Annexures 4, 5 and 6 of AIS: 090-2005.
6.10.1.2	At the rear: Red Reflective tape of width not less than 20 mm conforming to Annexures 4, 5 and 6 of AIS: 090-2005.
6.10.1.3.	The Reflective Tape shall be as close as practicable to horizontal, compatible with the shape, structure, design and operational requirements of the vehicle.
6.10.2.	Position:
6.10.2.1.	Width:
	Reflective Tape at the front and at the rear shall be affixed across the width of the body of the vehicle. This condition will be deemed to be met if the requirement of 6.10.2.1.1 or 6.10.2.1.2 is met.
6.10.2.1.1	The projected distance between extreme edges of the reflective tape elements, as mounted on the front / rear surface of vehicle shall equate to at least : a) At Front : 65 per cent of the projected width of the Front body surface of the vehicle and b) At Rear: 75 per cent of the projected width of the Rear body surface of the vehicle.
6.10.2.1.2	However, if the manufacturer can prove to the satisfaction of the test agency responsible for type approval that it is impossible to achieve the value referred to in paragraph 6.10.2.1.1. above, the cumulative projected width for front or rear may be reduced to 60 per cent and shall be indicated in the communication document and test report.
6.10.2.2	Length: No special requirement.
6.10.2.3.	Height: Not less than 250 mm nor more than 1500 mm above the ground;

6.10.3	Visibility
6.10.3.1.	The Reflective Tape shall be considered visible, if at least 70 per cent of the illuminating surface of the installed reflective tape is visible when viewed by an observer positioned at any point within the observation planes defined below:
6.10.3.1.1	For rear and front Reflective Tape the observation plane is perpendicular to the longitudinal axis of the vehicle situated 25 m from the extreme end of the vehicle and bounded by:
	a) In height, by two horizontal planes 1 metre and 3 metre above the ground;
	b) In width, by two vertical planes which form an angle of 4° outwards from the vehicle's median longitudinal plane and which pass through the intersection of the vertical planes parallel to the vehicle's median longitudinal plane delimiting the vehicle's overall width, and the plane perpendicular to the longitudinal axis of the vehicle that delimits the end of the vehicle.
6.10.4.	Orientation
	To the rear and to the front: As close as practicable to being parallel to the transverse plane of the vehicle, compatible with the shape, structure, design and operation requirements of the vehicle, if this is not possible, it shall follow as close as practicable the contour of the outer shape of the vehicle.
6.10.5.	Other requirements
	Reflective Tape shall be considered continuous if the distance between adjacent elements are as small as possible and shall not exceed 300 mm.

PRINTED BY

THE AUTOMOTIVE RESEARCH ASSOCIATION OF INDIA

P. B. NO. 832, PUNE 411 004

ON BEHALF OF

AUTOMOTIVE INDUSTRY STANDARDS COMMITTEE

UNDER

CENTRAL MOTOR VEHICLES RULES - TECHNICAL STANDING COMMITTEE

SET-UP BY

MINISTRY OF ROAD TRANSPORT & HIGHWAYS

(DEPARTMENT OF ROAD TRANSPORT & HIGHWAYS)

GOVERNMENT OF INDIA

17th January 2020

AMENDMENT 1 28 September 2016
To
AIS-009 : 2001

**Automotive Vehicles - Installation Requirements of Lighting and Light-Signalling
Devices for 2 and 3 Wheelers, their Trailers and Semi-Trailers**

1.0 Page 20,

Add following new clause 21.0 after 20.0

21.0 Transitory Provisions

21.1 Till AIS 009 (Rev 1) - 2011 is notified by MoRTH, for the verification of compliance to para (bb) of clause (b) of sub rule 1 of rule 105 (as introduced vide notification number GSR 188 (E) dated 22nd February 2016), requirement of clauses 2.5.17, 5.10, 5.11, 5.13, 6.13, 6.13.7.1 and 11.5 of AIS-009 (Rev. 1): 2011 shall be applicable.

Explanatory Note: - The clauses 5.10, 5.11, 6.13.7.1 and 11.5 were amended/ incorporated in AIS 009 (Rev 1):2011 by amendment.

PRINTED BY

THE AUTOMOTIVE RESEARCH ASSOCIATION OF INDIA

P. B. NO. 832, PUNE 411 004

ON BEHALF OF

AUTOMOTIVE INDUSTRY STANDARDS COMMITTEE

UNDER

CENTRAL MOTOR VEHICLES RULES - TECHNICAL STANDING COMMITTEE

SET-UP BY

MINISTRY OF ROAD TRANSPORT & HIGHWAYS

(DEPARTMENT OF ROAD TRANSPORT & HIGHWAYS)

GOVERNMENT OF INDIA

28 September 2016

AIS - 009/2001

AUTOMOTIVE INDUSTRY STANDARD

**Automotive Vehicles -
Installation Requirements of Lighting
and Light-Signalling Devices for 2 and
3 Wheelers, their Trailers and
Semi-Trailers**

PRINTED BY:

THE AUTOMOTIVE RESEARCH ASSOCIATION OF INDIA
P. B. NO. 832, PUNE 411 004

ON BEHALF OF :
AUTOMOTIVE INDUSTRY STANDARDS COMMITTEE

UNDER
CENTRAL MOTOR VEHICLE RULES - TECHNICAL STANDING COMMITTEE

SET-UP BY
MINISTRY OF ROAD TRANSPORT & HIGHWAYS
GOVERNMENT OF INDIA

December 2001

Status chart of the Standard to be used by the purchaser
for updating the record

Sr. No.	Corr- igenda.	Amend- Ment	Revision	Date	Remark	Misc.

General remarks :

INTRODUCTION

The Government of India felt the need for a permanent agency to expedite the publication of standards and development of test facilities in parallel when the work on the preparation of the standards is going on, as the development of improved safety critical parts can be undertaken only after the publication of the standard and commissioning of test facilities. To this end, the Ministry of Surface Transport (MOST) has constituted a permanent Automotive Industry Standard Committee (AISC) vide order No.RT-11028/11/97-MVL dated September 15, 1997. The standards prepared by AISC will be approved by the permanent CMVR Technical Standing Committee (CTSC). After approval, the Automotive Research Association of India, (ARAI), Pune, being the Secretariat of the AIS Committee, has published this standard. For better dissemination of this information ARAI may publish this document on their Web site.

Installation of lighting and light signalling devices for two and three wheelers, is a safety requirement. This standard prescribes the requirements of such installation.

Considerable assistance has been taken from the following EEC directives and ECE Regulations in preparing this standard.

1. **EEC Directive No. 93/92/EEC** on installation of lighting and light signalling devices on two or three wheeled motor vehicles.
2. **ECE Regulation 53:** Uniform provisions concerning the approval of category L3 vehicles with regard to installation of lighting and light signalling devices.

The Committee responsible for preparation of this standard is given in Annex B.

Automotive Vehicles - Installation Requirements of Lighting and Light - Signalling Devices for 2 and 3 Wheelers, their Trailers and Semi-Trailers

1. SCOPE

This standard lays down the requirements of installation of lighting and light signalling devices for two and three wheelers. This standard is also applicable to:

- two wheeled vehicles fitted with a side car,
- three wheeled vehicles designed to draw a trailer/semi-trailer,
- trailers and semi-trailers drawn by a three-wheeled vehicle and
- quadra cycles as defined in IS 14272 (Under revision).

Note 1: Doc: TED 1 (375) P Dec. 2001 is draft document for first revision of IS 14272. Quadra cycle is defined in Clause 3.7 of this document.

2. REFERENCES

- (1) IS 9435: 1980 Terms and definitions relating to dimensions of road vehicles.
- (2) IS 9211: 1979 Denominations and definitions of weights of road vehicles.
- (3) IS 11422:1985 Terms and definitions of weights of scooters and motor cycles.
- (4) IS 11432: 1985 Terms and definitions of dimensions of motorcycles.
- (5) IS 11571: 1986 Terms and definitions of dimensions of scooters.
- (6) IS 14413: 1996 Automotive vehicles: Tell tale symbols and controls on two wheeled and three wheeled vehicles.
- (7) Doc: TED 1(375) P Dec.2001*Draft Indian Standard Automotive Vehicles – Types – Terminology [First Revision of IS 14272(Part 1)-1995].* {See also note 1.}
- (8) AIS 007/1998 Information on Technical Specifications to be submitted by the Manufacturer.
- (9) AIS 008/2001 Installation Requirements of Lighting and Light - Signalling Devices for Motor Vehicle having more than Three Wheels, Trailer and Semi-Trailer excluding Agricultural Tractor and Special Purpose Vehicle.
- (10) AIS 010 } AI Standards for performance requirements of
→ lighting and light signalling devices (Under
preparation).
- (11) AIS 012 }
- (12) ECE regulations R20 and R50.

3. DEFINITIONS

The definitions given in AIS-008 shall be applicable to this standard also. The additional terms are defined below.

3.1 **Vehicle type:** means vehicles which do not differ in such essential aspects as:

3.1.1 dimensions and external shape of vehicle;

3.1.2 number and positioning of the devices;

3.1.3 The following shall, likewise, not be deemed to be 'vehicles of a different type':

3.1.3.1 Vehicles which differ within meaning of 3.1.1 and 3.1.2, but not in such a way as to entail a change in type, number, positioning and geometric visibility of the lamps prescribed for vehicle type in question;

3.1.3.2 Vehicles on which optional lamps are fitted or absent.

3.2 **Transverse plane:** means a vertical plane perpendicular to the longitudinal median plane of the vehicle.

3.3 **Unladen vehicle:** means vehicle in kerb weight condition as prescribed in IS:9211-1979 or IS:11422-1985 as applicable.

3.4 **Front position lamp:** means the lamp used to indicate presence of the vehicle when viewed from front.

3.5 **Rear position lamp:** means lamp used to indicate presence of the vehicle when viewed from rear.

3.6 **Longitudinal median plane of vehicle:** as defined in IS:11432-1985, IS:11571-1986 or IS:9435-1980 as applicable to the type of vehicle.

3.7 **Apparent surface in the direction of reference axis:** means the apparent surface when viewed in the direction of the reference axis of the lamp.

4. FITMENT OF LAMPS

4.1 **Mandatory**

4.1.1 Every vehicle shall be fitted with lamps, as per details given in Table 1, subject to the conditions given in 4.1.2.

4.1.2 **Other conditions for applicability**

4.1.2.1 In the case of three wheelers, one headlamp is permitted only when overall width of vehicle is not exceeding 1400 mm and where the seat for driver is located centrally. In such cases, only amber coloured front position lamps are permitted.

4.1.2.2 One direction indicator lamp per side is allowed if all the geometric visibility requirements are satisfied.

4.1.2.3 The requirements for quadra cycle are same as those for three wheeler.

- 4.1.2.4 A trailer or semi-trailer drawn by three wheeled vehicle, shall be fitted with all the lighting and light-signalling devices prescribed to be fitted at rear of a three-wheeled vehicle.”

4.2 Optional

In addition, vehicles may be fitted with any of the following lamps, provided that requirements of installation prescribed in this standard are complied with:

- 4.2.1 The lighting and light signalling devices, which are mandatory only for certain type of vehicles as per 4.1.2, are permitted as optional fitments for those type of vehicles, for which they are not mandatory as per the same para.
- 4.2.2 Lamps other than those listed in Table 1, but permitted for M1 or N1 category of vehicles as per AIS 008/2001 are also permitted.
- 4.2.3 Fitment of amber colour non triangular retro-reflector is permitted on each side of the vehicle.
- 4.2.4 Fitment of front and rear fog lamps are optional. If fitted, they shall comply with requirements given in Annex A.
- 4.2.5 In case of two wheelers, fitment of one or two front position lamps is optional.

Table 1: Number and colour of lamps (See 4.1.1)

Lamps		Colour	Number of lamps
a)	Main-Beam Head Lamp	White	One or two (See 4.1.2.1) Not mandatory for two wheeler of L1 category.
b)	Dipped-Beam Head Lamp	White	One or two (See 4.1.2.1).
c)	Direction Indicator Lamps	Amber	One at the front and one at the rear on each side (See 4.1.2.2). Not mandatory for L1 category of two wheelers. (See Note 2).
d)	Rear Position Lamp (Tail Lamp)	Red	One or two in the case of two wheelers. Two in the case of three wheelers. Two or three in case two wheeler fitted with side car, one of which shall be on side car.
e)	Rear Retro-Reflector	Red	One or two in the case of two wheelers. Two in the case of three wheelers. Two or three in case two wheeler fitted with side car, one of which shall be on side car.
g)	Stop Lamp	Red	One or two in the case of two wheelers. Two in the case of three wheelers. Two or three in case two wheeler fitted with side car, one of which shall be on side car.
h)	Rear Registration Mark (Rear Number Plate) Illuminating Lamp	White	One.
j)	Hazard Warning Lamp	Amber	Same as those for c). Mandatory only for three wheelers-goods carrier.
k)	Reversing Lamp	White	One or two for 3 wheelers.
l)	Front Position Lamp	White or Amber	Two in the case of 3 wheelers. (See 4.1.2.1) One on side car, if a side car is attached to a two wheeler.
m)	Top Lights Front	White	Two each for front and rear, at the top right and left corners. Mandatory only for three wheelers- goods carrier with width exceeding 2.1m
n)	Top Lights Rear	Red	
p)	Pedal Retro-Reflector	Amber	Two on each pedal only in case of L1 category of two wheelers fitted with pedals.

Note2: Proviso of Rule No. 102 of CMVR exempts two wheelers with engine capacity not exceeding 70cc from fitment of direction indicator lamps. In this standard the exemption has been changed to L1 category of two wheelers. The proposal for defining L1 category of two wheelers as a “two wheeler with maximum speed not exceeding 45 km/h and engine capacity not exceeding 50 cc if fitted with a thermic engine”, is under consideration of CMVR TSC. The amendment to Proviso of Rule No. 102 of CMVR to this effect is expected to be issued to avoid contradiction.

4.3 Prohibited lamps

- 4.3.1 No lamps other than those specified in 4.1 and 4.2 shall be fitted, other than those needed for illuminating the instrument panel, and inside the vehicles etc.
- 4.3.2 No lamp giving a red light to the front or showing light other than red to the rear shall be permitted, except the following:
- Interior lighting of the vehicle,
 - Amber light for direction indicator lamp,
 - White light illuminating the rear registration mark,
 - White light for reversing lamp.

5.0 REQUIREMENTS

The lamps shall be fitted in such a way that following requirements are met.

- 5.1 The lighting and light-signalling devices shall be so installed that under normal conditions of use and not withstanding any vibration to which they may be subjected, they retain the characteristics laid down and enable the vehicle to comply with requirements of this standard. In particular, it shall not be possible for the adjustment of lamps to be inadvertently disturbed.
- 5.2 The illuminating lamps shall be so fitted that alignment can be easily set correctly.
- 5.3 Reference axis of all light-signalling devices when fitted to the vehicle shall be parallel to horizontal bearing plane of the vehicle.
- It shall be perpendicular to longitudinal median plane of the vehicle in the case of side retro-reflectors.
- It shall be parallel to longitudinal median plane of the vehicle in the case of all other signalling devices.
- In each direction a tolerance of 3° is allowed.
- In addition any specific instructions as regards fitting laid down by the manufacturer shall be complied with.
- 5.4 Height and alignment of lamps:
- 5.4.1 The height and alignment of lamps shall be checked, in the absence of specific instruction, with the vehicle unladen and located on a flat horizontal surface, with its longitudinal median plane being vertical and its handlebar or steering wheel in the straight ahead position. The tyre pressure shall be that specified by the manufacturer for specific loading conditions laid down for measurement of height of lamps.

- 5.4.2** The maximum height above ground shall be measured from the highest point, and the minimum height from the lowest point of the apparent surface in the direction of reference axis. The minimum height above ground of dipped-beam headlamps shall be measured from the lower edge of the lens, or the reflector if the latter is higher.
- 5.5** The position, as regards width, shall be determined from that edge of apparent surface in the direction of reference axis, which is the furthest from longitudinal median plane of the vehicle, when referred to the overall width, and on the inner edges of apparent surface in the direction of reference axis when referred to distance between lamps.
- 5.6** In the absence of specific requirements, lamps constituting a pair shall;
- 5.6.1 be installed on the vehicle symmetrically in relation to longitudinal median plane.
- 5.6.2 be symmetrical to each other in relation to longitudinal median plane.
- 5.6.3 fulfill the same colourimetric requirements (component type approval).
- 5.6.4 have substantially identical photometric characteristics.
- 5.7** In the absence of specific requirements, lamps having different functions may be independent or be grouped or reciprocally incorporated or combined in one device, provided that such lamp comply with the requirement applicable to it.
- 5.8** In the absence of specific instructions no lamps other than director indicator lamps and hazard-warning signal shall emit a flashing light.
- 6.0 LOCATION- WIDTH**
- 6.1 Head Lamp, Main-Beam And Dipped-beam**
- 6.1.1 When the vehicle is fitted with a main-beam headlamp, which is reciprocally incorporated with a dipped-beam headlamp, its reference centre shall be on longitudinal median plane of the vehicle.
- 6.1.2 When the vehicle is fitted with two lamps, (either independent or reciprocally incorporated main-beam, dipped-beam headlamp or another front lamp) and one is above the other, their reference centre shall be on longitudinal median plane of the vehicle.

- 6.1.3 When the vehicle is fitted with more than one lamp, (either independent or reciprocally incorporated main-beam, dipped-beam headlamp or another front lamp) and they are fitted to one side of each other, their reference centres shall;
- 6.1.3.1 be symmetrical in relation to longitudinal median plane of the vehicle, and
- 6.1.3.2 in the case of two wheelers, the horizontal distance between the inner edges of the apparent surfaces in the direction of reference axes shall not exceed 200 mm and
- 6.1.3.3 in the case of three wheelers, the edges of the apparent surfaces in the direction of the reference axes furthest from longitudinal median plane of vehicle shall not be more than 300 mm from the extreme outer edge of the vehicle and
- 6.1.3.4 in case of three wheelers with two headlamps, the distance between the inner edges of the apparent surfaces in the direction of reference axes shall be minimum of 300 mm when overall width of the vehicle does not exceed 1400 mm and minimum of 500 mm when overall width of the vehicle exceeds 1400 mm.

6.2 Direction Indicator Lamps- Front

- 6.2.1 In the case of two wheelers:
- 6.2.1.1 There shall be a minimum distance of 240 mm between the inner edges of apparent surfaces in the direction of reference axes.
- 6.2.1.2 They shall be situated outside the vertical longitudinal planes that are tangent to the outer edges of the apparent surfaces in the direction of reference axes of the headlamp(s);
- 6.2.2 In the case of three wheelers and two wheelers fitted with side car:
- 6.2.2.1 The edges of the apparent surfaces in the direction of reference axes furthest from longitudinal median plane shall not be more than 300 mm from the extreme outer edge of the vehicle.
- 6.2.2.2 The inner edges of apparent surfaces in the direction of reference axes shall be at least 500 mm apart.
- 6.2.3 The minimum intensity of direction indicator lamps (type approval component value) shall not be less than values specified below for different separation distance between nearest points of;
- i) apparent surfaces in the direction of the reference axes of the direction indicator lamps and
- ii) that of dipped-beam headlamps.

Separation distance (mm)		Minimum Indicator Intensity (cd)
More than	up to	
--	20	400
20	40	250
40	75	175
75	--	90

- 6.2.3.1 **Transitory provision:** Till type approval of direction indicator lamps is implemented.

If the separation distance is more than 75 mm, the requirements of this para, are deemed to be complied with.

If the separation distance is not more than 75 mm, the intensity of the front direction indicator lamps shall be measured as per the procedure given in ECE regulation 50

6.3 **Direction Indicator Lamps-Rear**

- 6.3.1 In the case of two wheelers, the distance between the inner edges of the apparent surfaces in the direction of reference axes of rear indicator lamps shall be at least 180 mm subject to compliance with the requirements given in para 4.12 of AIS-008, even when registration number plate is fitted.

- 6.3.2 In the case of three wheelers, and two wheelers fitted with side car, the condition given in 6.2.2 shall be applicable.

6.4 **Rear Position Lamp (Tail Lamp)**

- 6.4.1 The reference centre shall be located on longitudinal median plane of the vehicle if there is only one rear position lamp or, if there are two rear position lamps, these shall be symmetrical to longitudinal median plane of the vehicle.
- 6.4.2 In the case of vehicles with two rear wheels, and two wheelers fitted with side car, the edges of the apparent surfaces in the direction of the reference axes furthest from longitudinal median plane of vehicle shall not be more than 300 mm from the extreme outer edge of the vehicle.
- 6.4.3 In the case of three wheelers, the distance between the inner edges of the apparent surfaces in the direction of reference axes shall be minimum of 400 mm when overall width of the vehicle does not exceed 1400 mm and minimum of 600 mm. when overall width of the vehicle exceeds 1400 mm.

- 6.4.4 In the case of two wheelers with a side car, one rear position lamp shall be fitted on side car, in addition to those fitted on the two wheeler.
- 6.5 Stop Lamp:** Same conditions prescribed for Rear Position Lamp (6.4) shall be applicable.
- 6.6 Rear Retro-Reflector**
- 6.6.1 The reference centre shall be located on longitudinal median plane of the vehicle if there is only one retro-reflector. If there are two retro-reflectors, these shall be symmetrical to longitudinal median plane of the vehicle.
- 6.6.2 In addition, in the case of three wheelers and two wheelers fitted with a side car, the edges of the illuminating surfaces furthest from longitudinal median plane of vehicle shall not be more than 300 mm from the extreme outer edge of the vehicle. The distance between the inner edges of the illuminating surfaces shall be minimum of 400 mm when overall width of the vehicle does not exceed 1400 mm and minimum of 500 mm. when overall width of the vehicle exceeds 1400 mm.
- 6.7 Front Position Lamp**
- 6.7.1 An independent front position lamp, if fitted above or below another front lamp, the reference centre of front position lamp shall be located on longitudinal median plane of the vehicle.
- 6.7.2 An independent front position lamp if fitted to one side of another front lamp, reference centre shall be symmetrical in relation to longitudinal median plane of the vehicle.
- 6.7.3 A front position lamp that is reciprocally incorporated with another front lamp shall be fitted in such a way that its reference centre lies on longitudinal median plane of the vehicle.
- 6.7.4 Two front position lamps, of which one or both are combined with another front lamp, shall be installed in such a way that their reference centres are symmetrical in relation to longitudinal median plane of the vehicle.
- 6.7.5 In the case of three wheelers and two wheelers fitted with side car, the edges of the apparent surfaces in the direction of reference axes furthest from longitudinal median plane of vehicle shall not be more than 300 mm from the extreme outer edge of the vehicle.
- 6.7.6 In the case of three wheelers, the distance between the inner edges of the apparent surfaces in the direction of reference axes shall be minimum of 400 mm when overall width of vehicle does not exceed 1400 mm and minimum of 600 mm when overall width of vehicle exceeds 1400 mm.

- 6.8 Hazard Warning Lamp:** The conditions given in 6.2 and 6.3 shall be applicable.
- 6.9 Reversing Lamp:** In case of two reversing lamps, they shall be mounted at rear, symmetrical with respect to longitudinal median plane of the vehicle. If there is only one, it may be mounted to one side of the vehicle at rear.
- 7.0 LOCATION - LONGITUDINAL**
- 7.1 Head Lamp Main-Beam, Dipped-Beam and Front Position Lamp**
- 7.1.1 These lamps shall be at the front of the vehicle. This requirement is considered to have been met if the light emitted does not disturb the driver either directly or indirectly by means of rear-view mirrors and/or other reflective surfaces on the vehicle.
- 7.1.2 In any case, the distance between the edge of the apparent surfaces in the direction of the reference axes of any independent main-beam headlamp and the edge of that of dipped-beam headlamp shall not exceed 200 mm.
- 7.1.3 In the case of two main-beam headlamps the distance separating the apparent surfaces in the direction of reference axes of these two main-beam headlamps shall not exceed 200 mm.
- 7.1.4 In the case of two dipped-beam headlamps the distance separating the apparent surfaces in the direction of the reference axes of these dipped-beam headlamps shall not exceed 200 mm.
- 7.2 Direction Indicator Lamps and Hazard Warning Lamp**
- The distance towards front between the transverse plane corresponding to the longitudinal rearmost extremity of the vehicle and the centre of reference of rear indicators shall not exceed 300 mm.
- 7.3 Rear Position Lamp (Tail Lamp), Stop Lamp and Rear Retro-Reflector**
- These shall be fitted at the rear of the vehicle.
- 7.4 Side Retro-Reflector**
- They shall be fitted so that, under normal conditions, side retro-reflector cannot be masked by the rider or passenger nor by their clothing.
- 8.0 LOCATION - HEIGHT**
- 8.1** The height above ground level shall be as specified below, in Table 2.

- 8.2** In the case of three wheelers with only one head lamp, minimum height permitted for front position lamp shall be 800 mm.

9.0 LOCATION OF THE REAR REGISTRATION MARK ILLUMINATING LAMP

The positions shall be such that the lamp illuminates the area reserved for rear registration mark.

Table 2: Height of Lamps (See 8.1)			
	Lamp	Minimum	Maximum
a)	Main-Beam Head Lamp	450 mm	1200 mm
b)	Dipped-Beam Head Lamp	450 mm	1200 mm
c)	Direction Indicator Lamps and Hazard Warning Lamps	350 mm	1500 mm
d)	Rear Position Lamp (Tail Lamp)	350 mm	1500 mm
e)	Rear Retro-Reflector	250 mm	900 mm
f)	Stop Lamp	350 mm	1500 mm
g)	Front Position Lamp	350 mm	1500 mm
h)	Reversing Lamp	250 mm	1200 mm
j)	Side Retro-Reflector	300 mm	900 mm

10.0 GEOMETRIC VISIBILITY

- 10.1 Rear Registration Mark Illuminating Lamp:** The positions shall be such that the lamp illuminates the area reserved for rear registration mark.

- 10.2 Main-Beam Head Lamp:** The visibility of the illuminating surface, including its visibility in areas which do not appear to be illuminated in the direction of observation considered, shall be ensured within a divergent space defined by generating lines based on the perimeter of the illuminating surface and forming an angle of not less than 5° with the axis of reference of head lamp. The origin of angles of geometric visibility is the perimeter of the projection of the illuminating surface on a transverse plane tangent to the foremost part of the lens of head lamp.

- 10.3 Other lamps:** The minimum geometric visibility of other lamps as specified by the vertical angle α and horizontal angle β shall be as given in Table 3.

Table 3: Geometric Visibility Requirements (See 10.3)							
Lamp		Vertical Angle (α)		Horizontal Angle (β)			
		Up-ward	Down-ward	If one lamp		If two lamps	
				Right	Left	Out-ward	In-ward
a)	Dipped-beam Headlamp (See also 10.5)	15 ^o	10 ^o	45 ^o	45 ^o	45 ^o	10 ^o
b)	Direction Indicator Lamps & Hazard warning lamps (See also 10.4)	15 ^o	15 ^o	As per figures 1(a), 1(b), 1(c) & 1(d)			
c)	Rear Position Lamp (Tail Lamp) (See also 10.4)	15 ^o	15 ^o	80 ^o	80 ^o	80 ^o	45 ^o
d)	Rear Retro-Reflector (See also 10.4)	15 ^o	15 ^o	30 ^o	30 ^o	30 ^o	15 ^o
e)	Stop Lamp (See also 10.4)	15 ^o	15 ^o	45 ^o	45 ^o	45 ^o	30 ^o
f)	Front Position Lamp (See also 10.4)	15 ^o	15 ^o	80 ^o	80 ^o	80 ^o	45 ^o
g)	Reversing Lamp (See also 10.4)	15 ^o	5 ^o	45 ^o	45 ^o	45 ^o	30 ^o
h)	Side Retro-Reflector (See also 10.4)	15 ^o	15 ^o	30 ^o	30 ^o	Not applicable	

- 10.4** In the case of all lamps other than dipped-beam head lamp, a minimum downward of 5^o angle of geometric visibility is accepted if height of the lamp from ground does not exceed 750 mm.

- 10.5** In case of three wheelers fitted with only one dipped-beam head lamp, the geometric visibility shall be same as that prescribed for front position lamp.

11.0 ALIGNMENT

- 11.1** The following lamps shall be aligned towards the front:
(See also 5.3)

- main-beam head lamp,
- dipped-beam head lamp,
- front direction indicator lamps,
- front position lamp.

These lamps may turn with the steering.

- 11.2** The vertical inclination of dipped-beam shall remain between - 0.5% and - 2.5%. If external adjusting device is present, it shall be possible to adjust the vertical inclination to the above values.

- 11.3** The following lamps shall be aligned towards the rear:
(See also 5.3)
- a) rear position lamp (tail lamp),
 - b) stop lamp,
 - c) rear direction indicator lamp,
 - d) reversing lamp.

12.0 GROUPING WITH OTHER LAMPS

- 12.1** The lamps may be grouped with other lamps as in **Table 4**.

Table 4: Grouping of Lamps (See 12.1)

Lamp		May be grouped with
a)	Main-beam Head Lamp	Dipped-beam head lamp and other front lamps
b)	Dipped-beam Head Lamp	Main-beam head lamp and other front lamps
c)	Direction Indicator Lamps and Hazard Warning Lamps	One or more lamps
d)	Rear Position Lamp (Tail Lamp)	Any other rear lamp
e)	Rear Retro-Reflector	Any other rear lamp
d)	Stop Lamp	One or more other rear lamps
e)	Rear Registration Mark Illuminating Lamp	One or more other rear lamps
f)	Front Position Lamp	Any other front lamp
g)	Reversing Lamp	Any other rear lamp
h)	Side Retro-Reflector	Any other light-signalling device

13.0 COMBINING WITH OTHER LAMPS

The lamps may be combined with other lamps as in Table 5.

Table 5: Combining with Other Lamps (See 13.1)

Lamp		May be combined with
a)	Main-beam Head Lamp	No other lamp
b)	Dipped-beam Head Lamp	No other lamp
c)	Direction Indicator Lamps and Hazard Warning Lamps	No other lamp
d)	Rear Position Lamp (Tail Lamp)	Rear registration mark illuminating lamp
e)	Rear Retro-Reflector	No specific requirement
d)	Stop Lamp	No other lamp
e)	Rear Registration Mark Illuminating Lamp	Rear position lamp (Tail Lamp)
f)	Front Position Lamp	No other lamp
g)	Reversing Lamp	No other lamp

14. RECIPROCALLY INCORPORATED WITH OTHER LAMPS

14.1 The lamps may be reciprocally incorporated with other lamps as in Table 6.

Table 6: Reciprocal Incorporation with Other Lamps (See 14.1)

	Lamp	May be reciprocally incorporated with
a)	Main-Beam Head Lamp	Dipped-Beam Head lamp, front position lamp, front fog lamp
b)	Dipped-Beam Head Lamp	Head lamp main-beam, front position lamp and front fog lamp.
c)	Direction Indicator Lamps and Hazard Warning Lamps	No other lamp.
d)	Rear Position Lamp	Stop lamp, rear retro-reflector or both, rear fog lamp.
e)	Rear Retro-Reflector	No specific requirement.
d)	Stop Lamp	Rear position lamp.
e)	Rear Regist. Mark Illuminating Lamp	No other lamp.
f)	Front Position Lamp	Any other front lamp.
g)	Reversing Lamp	No other lamp.

15. ELECTRICAL CONNECTIONS

15.1 Main and Dipped-beam Head Lamps

The main-beam headlamps shall light simultaneously. Dipped-beam headlamps shall light simultaneously. All main-beam headlamps shall light when they are switched from dipped-beam to main-beam. All main-beam headlamps shall be extinguished simultaneously when switched from main-beam to dipped-beam. The dipped-beam headlamps may remain lit at the same time as the main-beam headlamps.

15.2 Direction Indicator lamps

It shall be possible to switch on direction indicator lamps independently of other lamps. All direction indicator lamps on one side of a vehicle shall be switched on and off by means of single control.

15.3 Rear Position Lamp (Tail Lamp)

Shall light simultaneously with dipped-beam head lamp, main-beam headlamp, rear registration mark illuminating lamp, and if fitted, front position lamp.

- 15.4 Stop Lamp**
In the case of two wheelers, stop lamp shall light up on actuation of any of the controls, which actuate the brakes on any wheel. In the case of three wheelers, it shall light up on actuation of the foot operated brake control.
- 15.5 Rear Registration Mark Illuminating Lamp**
Shall light simultaneously with dipped-beam headlamp, main-beam headlamp, front position lamp and rear position lamp.
- 15.6 Front Position Lamp (if fitted)**
Shall light simultaneously with dipped-beam head lamp, main-beam headlamp, rear registration mark illuminating lamp and rear position lamp.
- 15.7 Hazard warning lamp**
The signal shall be actuated by a separate control, which enables all of direction indicators to be supplied with current simultaneously.
- 15.8 Reversing Lamp**
Reversing lamp shall light up on engagement of reverse gear. However, it need not light up before the engine is started.
- 16.0 CIRCUIT-CLOSED TELL TALE**
The circuit-closed tell tale shall be as indicated below:
- 16.1 Main-Beam Head Lamp:** Shall be as per IS:14413-1996
- 16.2 Dipped-Beam Head Lamp:** Optional. If fitted, it shall be a green non flashing indicator light.
- 16.3 Direction Indicator lamps:** It shall be possible for rider from his riding seat to make out that direction indicating lamps are functioning correctly. Tell tale, if provided, shall be as per IS 14413 - 1996, as an operational tell tale, it shall remain extinguished or remain alight without flashing or show a marked change of frequency in the event of malfunction of any of direction indicator lamps.
- 16.4 Stop Lamp:** Prohibited.
- 16.5 Rear Position Lamp (Tail Lamp):** Optional. The device provided, where appropriate, for front position lamp may fulfill its function.
- 16.6 Rear Registration Mark Illuminating Lamp:** Optional. Its function may be fulfilled by the device provided, where appropriate, for front position lamp
- 16.7 Front Position Lamp:** Non-flashing green indicator light is mandatory. This telltale is not required if instrument lighting can only be switched on or off together with front position lamp.

- 16.8 Rear Fog Lamp:** If fitted with a rear fog lamp, non-flashing amber indicator light is compulsory.
- 16.9 Hazard Warning Lamp:** It shall be in the form of a red flashing light or, if there is no separate telltale, the simultaneous operation of the telltales specified in 16.3 is permitted.
- 16.10 Reversing Lamp:** Optional.
- 17. OTHER REQUIREMENTS**
- 17.1 Main-Beam Head Lamp**
- 17.1.1 The aggregate maximum intensity of main-beam headlamps which may be lit at the same time shall not exceed 225000 cd which corresponds to a reference value of 75. The sum of reference values of main-beam headlamps based on type approval results of main-beam head lamp shall not exceed 75. The reference value of maximum intensity of main-beam head lamp shall be calculated as:
Reference Value = $0.208 \times E_M$
Reference value shall be rounded off to 7.5, 10, 12.5, 17.5, 20, 25, 27.5, 30, 37.5, 40, 45 and 50.
Where E_M is the maximum illumination produced on the screen by main-beam headlamps, when tested as per AIS-010.
- 17.1.2 Till the type approval of head lamps as per AIS-010 is implemented, the following transitory provision shall be followed:
In the case of main-beam headlamps fitted with halogen bulbs, the maximum intensity of headlamps shall be measured.
Method of measurement for the maximum illumination, prescribed in ECE Regulation 20 shall be followed.
In the case of head lamps fitted with other filament lamps (such as S4, R2 etc.) a reference value of 10 shall be assigned for each main-beam head lamp.
- 17.2 Direction Indicator lamps**
- 17.2.1 The characteristics listed below shall be measured with electrical generator supplying current only to those circuits that are essential to operation of engine and lighting devices.
- 17.2.2 Actuation of the light-signalling device control shall be followed by illumination of the lamp within a maximum of one second and initial extinction of the lamp within a maximum of one and a half seconds.
- 17.2.3 In the case of all vehicles direction indicator lamps of which are supplied with direct current:
- 17.2.3.1 the flashing-light frequency shall be 90 ± 30 times per minute;

- 17.2.3.2 the direction indicator lamps on the same side of the vehicle shall flash at the same frequency and in phase.
- 17.2.4 Where a vehicle is fitted with direction indicator lamps which are supplied with alternating current, when the engine speed lies between idling and 100% of engine RPM at max. power, declared by the manufacturer:
- 17.2.4.1 The direction indicator lamps may flash on the same side of the vehicle, either simultaneously or alternately.
- 17.2.4.2 The lamps shall flash at a frequency of 90 ± 30 times per minute when the engine speed lies between 50 % and 100 % of the engine RPM at max. power, declared by the manufacturer.
- 17.2.4.3 The lamps shall flash at a frequency between $(90 + 30)$ and $(90 - 45)$ times per minute when the engine speed lies between the idling speed specified by the manufacturer and 50% of the engine RPM at max. power, declared by the manufacturer.
- 17.2.5 In the event of failure, other than a short circuit, of one direction indicator lamp, the other shall continue to flash, or remain lit, but the frequency in this state may be different from that specified.
- 17.2.6 The front lamps shall not be visible to the rear nor the rear lamps to the front within the zones defined in Figures 2 (a), 2(b) and (2c).

17.3 Rear Retro-Reflector

The illuminating surface of retro-reflector may have parts common with any other red rear lamp situated at the rear.

17.4 Hazard Warning Lamp

- 17.4.1 The flashing-light frequency shall be 90 ± 30 times per minute. Actuation of the light-signalling device shall be followed by illumination of the lamp within a maximum of one second and initial extinction of the lamp within a maximum of one and a half seconds.
- 17.4.2 It shall be possible to actuate hazard warning lamp even if the device for switching the engine on or off is in a position such that it is impossible for the engine to operate.

17.5 Side Retro-Reflector

The reference axis of retro-reflectors shall be perpendicular to median longitudinal plane of the vehicle and positioned outwards. Side retro-reflectors may move in line with the steering.

17.6 Pedal Retro-Reflector

The illuminating surface of retro-reflector shall be recessed within its frame. The reflectors shall be installed within the body of the pedal in such a way that they are clearly visible both to the front and to the rear of the vehicle. The reference axis of reflector, the shape of which shall be adopted to that of the body of the pedal, shall be put at right angles to the axis of pedal. The pedal reflectors need to be mounted only on vertical pedals which, by means of cranks or similar devices, may act as a means of propulsion instead of the engine. They need not be mounted on pedals acting as vehicle controls or solely as footrest for the driver or passenger.

18.0 TECHNICAL SPECIFICATION TO BE SUBMITTED

18.1 The specification submitted by the manufacturer at the time of applying for the type approval of the vehicle to this standard shall contain at least the information the paragraphs of AIS-007 listed in 18.1.1.

18.1.1 **1**, 1.1, 1.2, 1.3, 1.4, 1.5, 1.6, 1.7, **2**, 2.1, 2.2, **4**, 4.1, 4.1.1, 4.1.2, 4.1.3, 4.2, **6**, 6.1,6.2, 6.3, **7**, 7.6, 7.11.2, **34**, 34.2, 34.2.1, 34.2.2, 34.3, 34.3.1, 34.3.2, 34.4, 34.4.1, 34.4.2, **40**, 40.1, 40.1.1, 40.1.2, 40.1.3, 40.1.4, 40.2, 40.2.1, 40.2.2, 40.2.3, 40.2.4, **41**, 41.1, 41.2, 41.3, **42**, 42.1, 42.2, 42.3, **43**, 43.1, 43.2, 43.3, **44**, 44.1, 44.1.1, 44.1.2, 44.1.3, 44.2, 44.2.1, 44.2.2, 44.2.3, **45**, 45.1, 45.2, 45.3, **46**, 46.1, 46.2, 46.3, **47**, 47.1, 47.1.1, 47.1.2, 47.1.3, 47.2, 47.2.1, 47.2.2, 47.2.3, 47.3, 47.3.1, 47.3.2, 47.3.3, 47.4, **48**, 48.1, 48.1.1, 48.1.2, 48.1.3, 48.2, 48.2.1, 48.2.2, 48.2.3, 48.3, 48.3.1, 48.3.2, 48.3.3, **49**, 49.1, 49.1.1, 49.1.2, 49.1.3, 49.1.4, 49.1.5, 49.2, 49.2.1, 49.2.2, 49.2.3, 49.2.4, 49.2.5, 49.3, 49.3.1, 49.3.2, 49.3.3, 49.3.4, 49.3.5, **58**, 58.4, 58.6, 58.7 and 58.9.

18.2 In addition, the maximum intensity of main-beam headlamps (cd) and a diagram of the vehicle indicating the location of all lights and light-signalling devices and following dimensions (in mm) shall be submitted.

Note 3: This para is applicable only till such time the information given in this para is incorporated in AIS-007. Once such an amendment to AIS-007 is implemented, this para will not be an additional requirement.

18.2.1 Along the width of the vehicle (Applicable only in case there are more than one lamps for the same function).

18.2.1.1 Horizontal distance between the inner edges of the illuminating surfaces/ apparent surfaces in the direction of the reference axes, as applicable.

- 18.2.1.2 Distance between the outermost edges of illuminating surfaces/ apparent surfaces in the direction of the reference axes, as applicable, from the extreme outer edge of the vehicle.
- 18.2.1.3 Distance between the nearest points of the apparent surfaces in the direction of reference axes of the front direction indicators and that of dipped-beam headlamps. In case this dimension is less than 75 mm, specify the intensity of front direction indicator lamp.
- 18.2.2 Along length of the vehicle where applicable: Distance between the transverse plane corresponding to the extreme longitudinal rearmost extremity of the vehicle and center of reference of the rear direction indicator lamps.
- 18.2.3 Height: Heights of highest and lowest points of the outermost illuminating surface/ apparent surface in the direction of reference axis, as applicable, from ground.
- 18.2.4 Contour of the vehicle parts limiting the geometric visibility of the lamps (where applicable).
- 18.2.5 Reference axis of device.
- 18.2.6 Location of extreme outer edge of the vehicle.
- 18.2.7 Mark of the apparent surface in the direction of reference axis or illuminating surface of the device as declared by manufacturer.
- 18.2.8 Mark of longitudinal median plane of the vehicle.
- 18.3** If the above information is submitted in a consolidated form, for the type approval of the whole vehicle, it is not necessary to submit this information again.
- 18.4** Changes in the Technical Specifications already Type Approved:
- 18.4.1 Every modification pertaining to the information declared in accordance with Para 18.1, 18.2 shall be intimated by the manufacturer to the certifying agency.
- 18.4.2 If the changes are in parameters not related to the provisions, no further action need be taken.
- If the changes are in parameters related to the provisions, the Testing Agency may then consider, whether,
- a) the model with the changed specifications still complies with provisions; or,
 - b) any further verification is required to establish compliance.
- For considering whether any further verification is required or not, guidelines given in para 19 (Criteria for Extension of Approval) may be used.

- 18.4.3 In case of 18.4.2 b), verification for only those parameters which are affected by the modifications needs to be carried out
- 18.4.4 In case of fulfillment of criterion of para 18.4.2a) or after results of further verification as per para of 18.4.2 b) are successful, the approval of compliance shall be extended for the changes carried out.
- 19.0 CRITERIA FOR EXTENSION OF APPROVAL**
- 19.1** In case of following changes, the verification shall be carried out for establishing compliance of the changed parameters to the requirements specified in this standard:
- 19.2** Number of any of the mandatory lighting and light-signalling devices and any addition to fitment of optional lamps.
- 19.3** Dimensions prescribed in Para 18.2 (or the corresponding paragraphs of AIS-007 when the amendment to AIS-007 for the incorporating the above becomes effective)
- 19.4** In case any increase in the dimensions for which a minimum value is specified or any decrease in the dimensions for which a maximum value is specified in this standard, verification on the prototype is not required if the difference between the modified dimension declared by the manufacturer and the requirement specified in this standard is more than 25 mm.
- 19.5** If there are changes in the contour of the vehicle, which increase the geometric visibility, verification on the prototype is not required.
- 19.6** While approving fitment of different makes of lighting devices or light-signalling devices, if any of the parameters specified above are affected, verification of compliance to such parameters shall be carried out.
- 19.7** For changes other than the above, the provisions given in the Preamble of Annex C of AIS 017/2000 (Procedure for Type Approval and Certification of Vehicles for Compliance to Central Motor Vehicles Rules) may be followed.
- 20.0 CONFORMITY OF PRODUCTION REQUIREMENTS**
- Whole Vehicle COP procedure laid down by the Ministry of Road Transport and Highways shall be applicable. For the purpose of COP, verification of all parameters shall be carried out.

Fig. 1(a) (See 10.3)

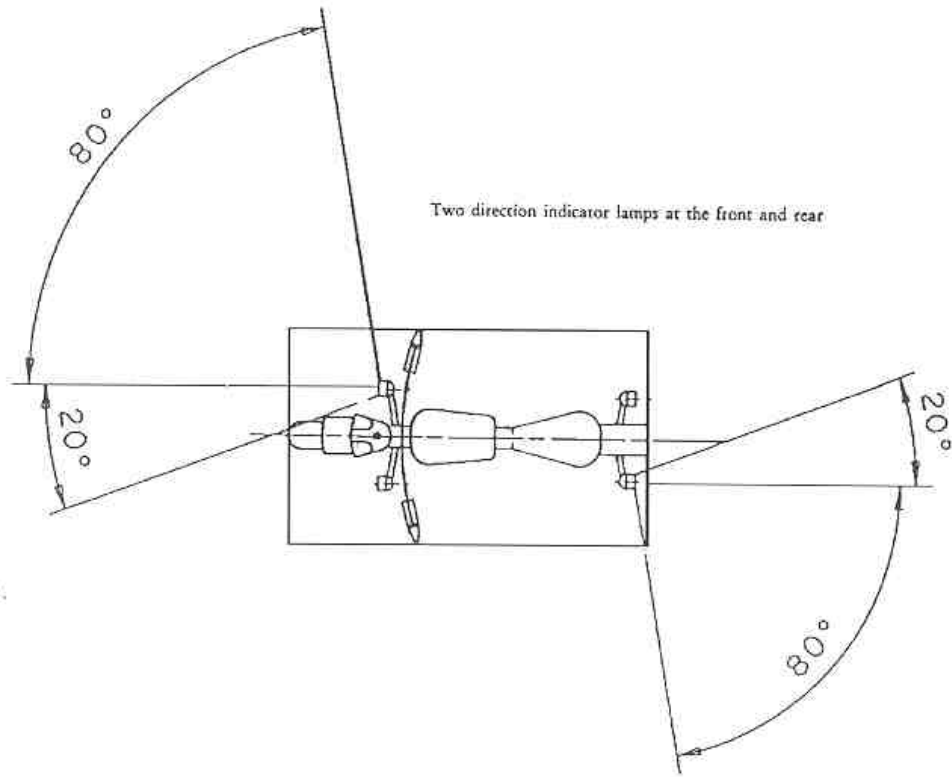
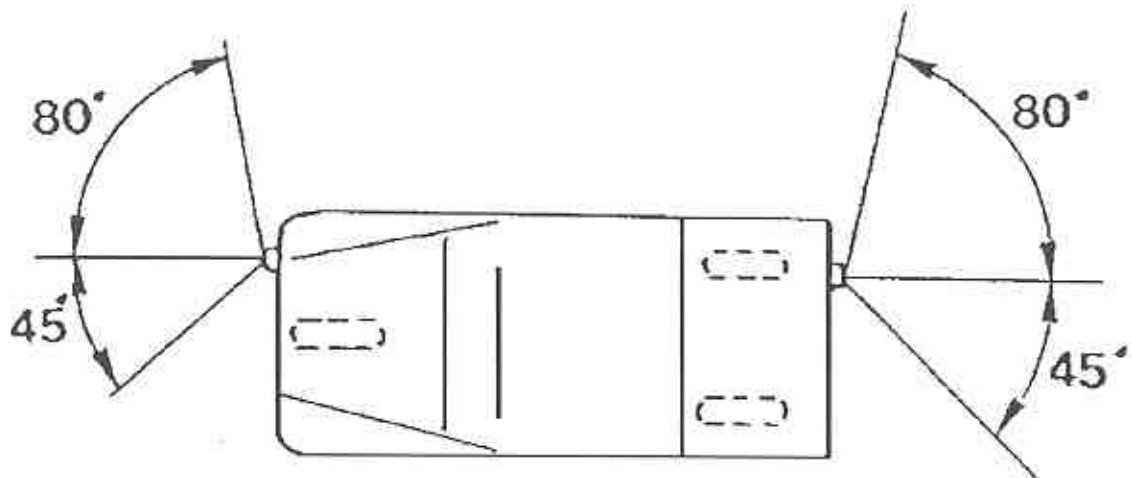

Fig. 1(b) (See 10.3)



Direction Indicator Lamp - Geometric Visibility.

Fig. 1 (c) (See 10.3)

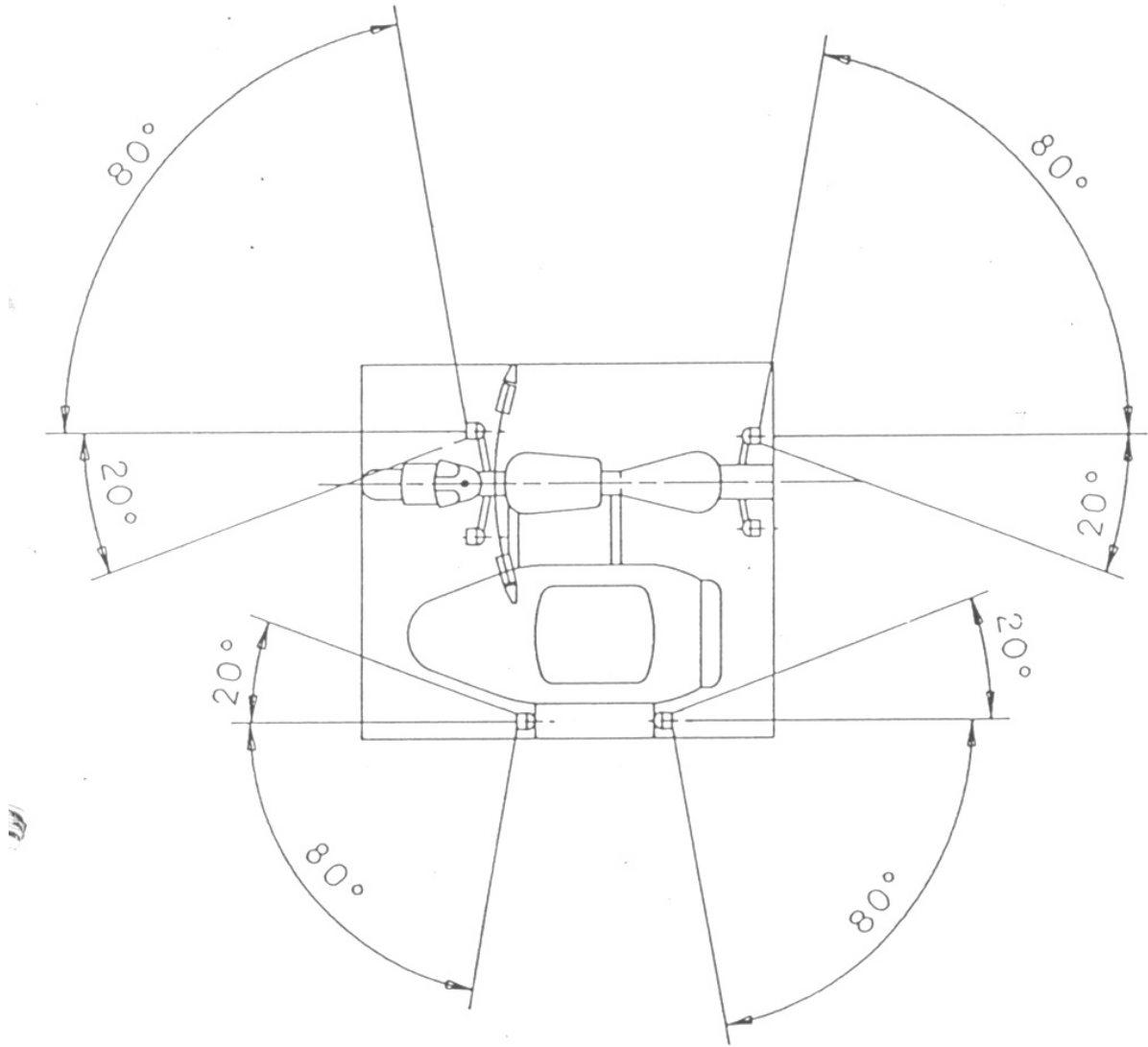

Fig. 1 (d) (See 10.3)

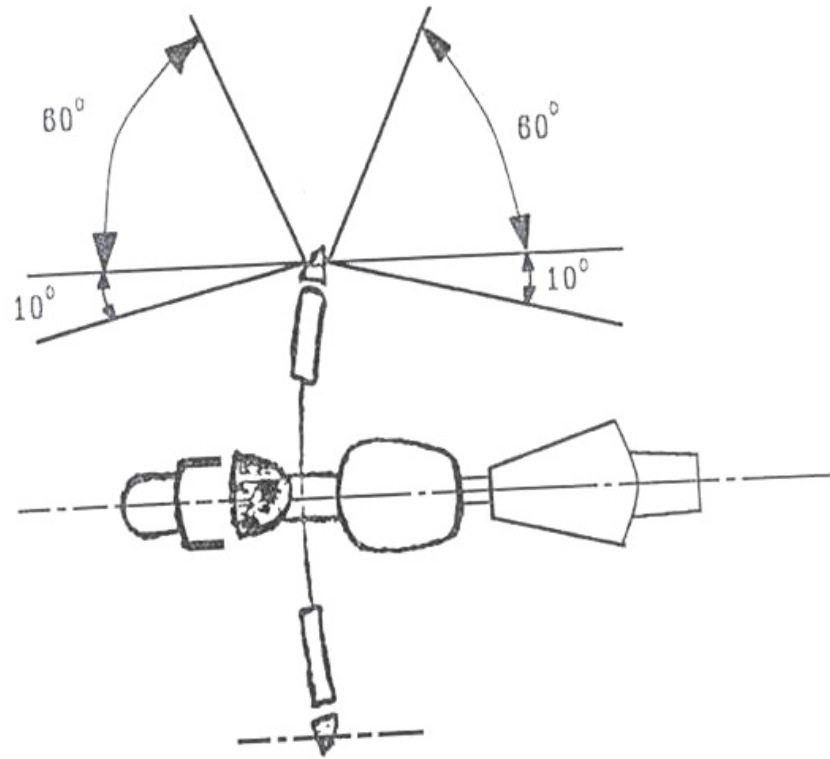
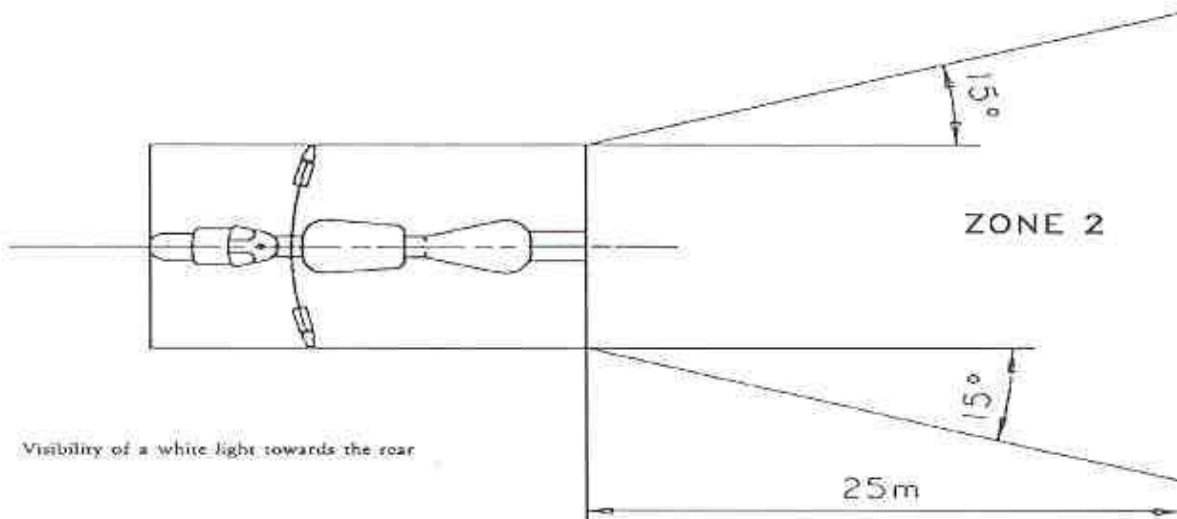
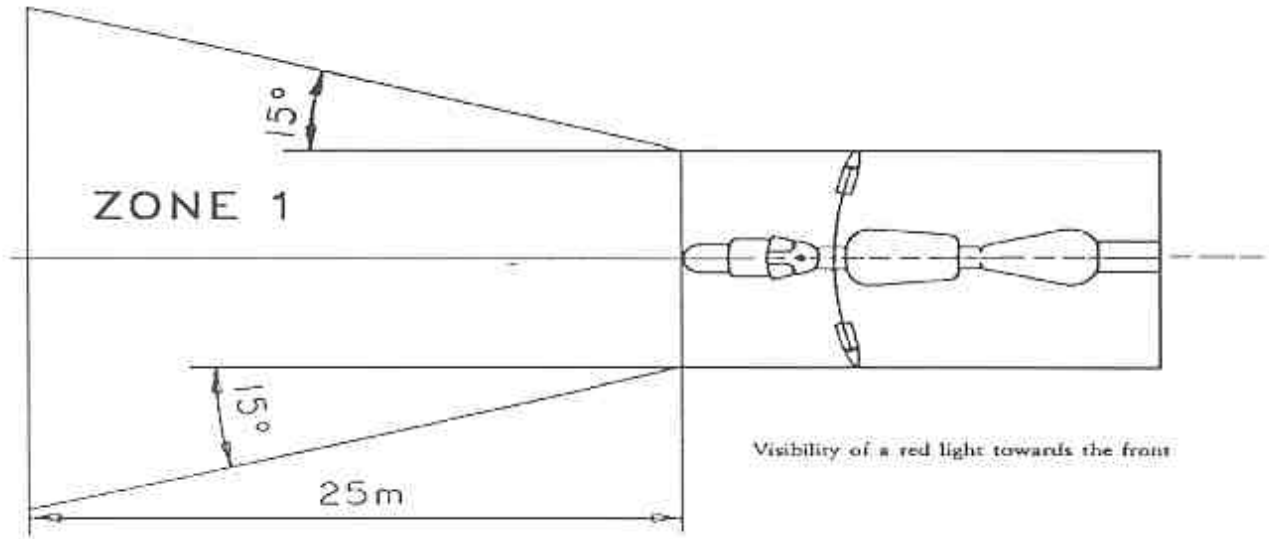
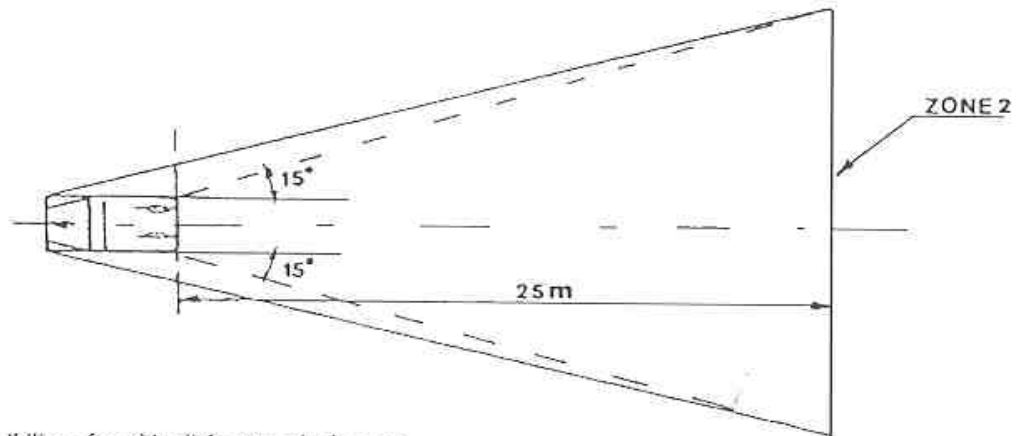

Fig. 2(a) (See 17.2.6)



As regard to height, Zone 1 and Zone 2, as seen by observer is limited within two horizontal planes which are 1 meter and 2.2 meter respectively above the ground.

Fig. 2(b) (See 17.2.6)



Visibility of a white light towards the rear

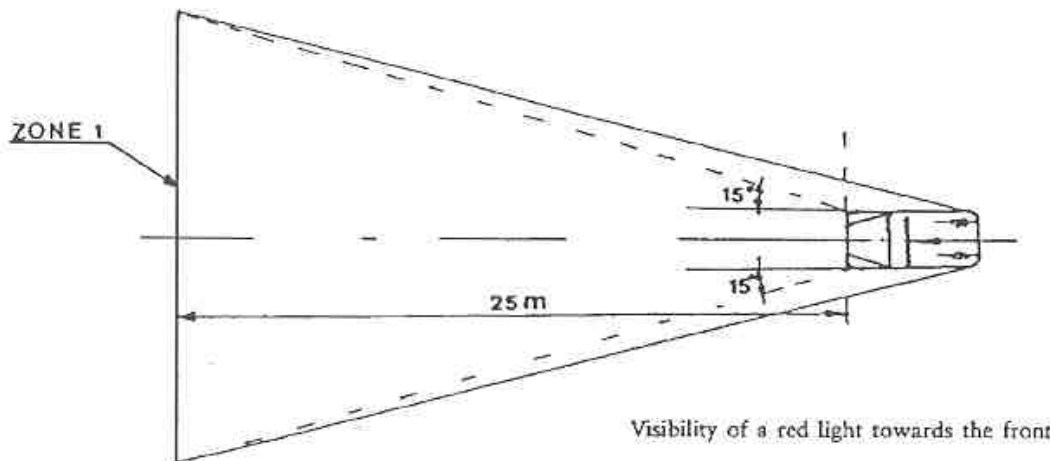

Visibility of a red light towards the front

As regard to height, Zone 1 & Zone 2, as seen by observer is limited within two horizontal planes which are 1 meter and 2.2 meter respectively above the ground.

Fig. 2 (c) (See 17.2.6)

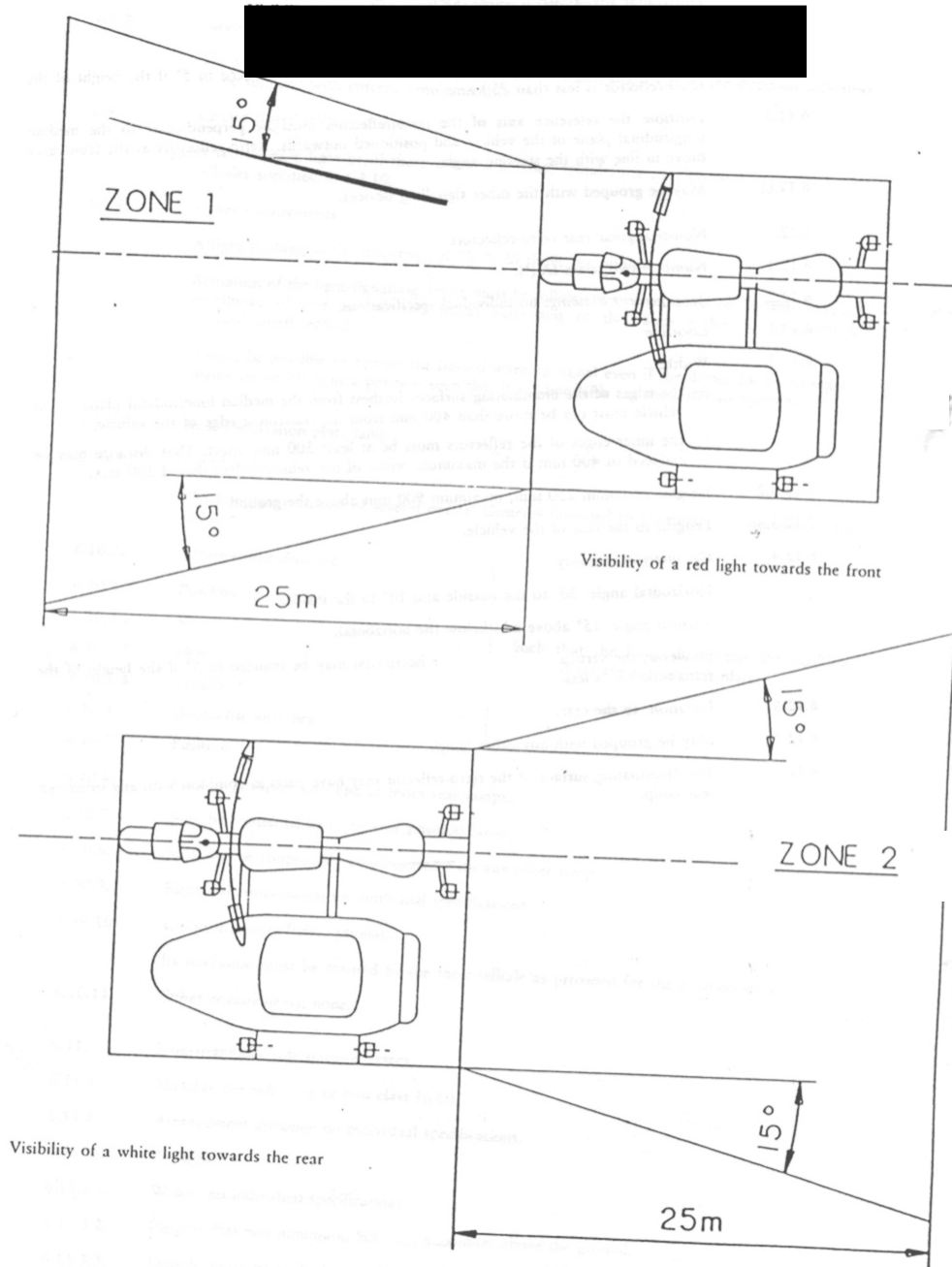

As regard to height, Zone 1 and Zone 2, as seen by observer is limited within two horizontal planes which are 1 meter and 2.2 meter respectively above the ground.

Annex A (See Para 4.2.4)
REQUIREMENTS FOR FITMENT OF FOG LAMPS

A1.0 This Annex describes the requirements related to front and rear fog lamps, if fitted in two and three wheeled motor vehicles. If the vehicles are fitted with fog lamps, the following requirements shall be complied with.

A2.0 NUMBER AND COLOUR

Lamp	Colour	Number
Front fog lamp	White or yellow	one or two
Rear fog lamp	Red	one or two

A3.0 POSITION (WIDTH)

A3.1 Front Fog lamp:

A3.1.1 The front fog lamp shall be installed above, below or next to another front lamp. If these lamps are on top of each other, the reference centre of the fog lamp shall be located within the longitudinal median plane of the vehicle. If the two lamps are side by side, their reference centres shall be symmetrical in relation of the longitudinal median plane of the vehicle. A front fog lamp that is reciprocally incorporated with another front lamp shall be installed in such a way that its reference centre is situated in a longitudinal median plane of the vehicle.

Two front fog lamps, one or both of them reciprocally incorporated with another front lamp, shall be installed in such a way that their reference centres are symmetrical in relation of the longitudinal median plane of the vehicle.

A3.1.2 In case of three wheelers, in addition, the edges of the apparent surface in the direction of reference axis furthest from the longitudinal median plane of the vehicle shall not be further than 400 mm from the outermost edge of the vehicle.

A3.2 Rear Fog lamp:

A.3.2.1 The rear fog lamp shall be installed above, below or next to another rear lamp. If these lamps are on top of each other, the reference centre of the fog lamp shall be located within the medial longitudinal plane of the vehicle. If the two lamps are side by side, their reference centres shall be symmetrical in relation of the longitudinal median plane of the vehicle. A rear fog lamp that is reciprocally incorporated with another rear lamp shall be installed in such a way that its reference centre is situated in a longitudinal median plane of the vehicle.

Two rear fog lamps, one or both of them reciprocally incorporated with another rear lamp, shall be installed in such a way that their reference centres are symmetrical in relation of the longitudinal median plane of the vehicle.

A3.2.2 In addition, in case of vehicles with two rear wheels, and two wheelers fitted with side car, when two fog lamps are fitted, the edges of the apparent surfaces in the direction of reference axes furthest from the longitudinal median plane of vehicle shall not be more than 300 mm from the outermost part of the vehicle.

The distance between the inner edges of the apparent surfaces in the direction of reference axes shall be minimum of 400 mm when the overall width of the vehicle does not exceed 1400 mm and minimum of 600 mm when the overall width of the vehicle exceeds 1400mm.

A4.0 POSITION-HEIGHT

A4.1 Front Fog Lamp: The minimum height shall not be less than 250mm and the highest point of the apparent surface in the direction of reference axis shall not be above the highest point of the apparent surface in the direction of reference axis of the dipped beam head lamp.

A4.2 Rear Fog Lamp: The minimum height shall not be less than 250mm and the maximum is 900mm in the case of two wheelers and two wheelers with side car and 1000mm in case of three wheelers

A5.0 POSITION- LENGTH

A5.1 Front Fog Lamp: Same as Para 7.1.1.

A5.2 Rear Fog Lamp: At the rear of the vehicle. The distance between the apparent surfaces in the direction of reference axes of the rear fog lamp and that of the stop lamp shall be at least 100mm.

A6.0 GEOMETRIC VISIBILITY: The minimum geometric visibility as specified by the vertical angle α and horizontal angle β shall be as given below:

Lamp			Vertical Angle (α)		Horizontal Angle (β)			
			Upward	Downward	If one lamp		If two lamps	
					Right	Left	Outward	Inward
a)	Front Fog Lamp	Fog	5 ^o	5 ^o	45 ^o	45 ^o	45 ^o	10 ^o
b)	Rear Fog Lamp	Fog	5 ^o	5 ^o	25 ^o	25 ^o	25 ^o	25 ^o

A6.0 GENERAL:

A6.1 Front fog lamp(s) shall be aligned towards the front and may move with steering angle. Rear fog lamp(s) shall be aligned towards rear.

A6.2 Front fog lamps may be grouped with any other front lamp and shall not be combined with any other front lamp.

A6.3 Rear fog lamps may be grouped with any other rear lamp and shall not be combined with any other rear lamp.

- A6.4** Front fog lamp may be reciprocally incorporated with front main-beam headlamp and front position lamp.
- A6.5** Rear fog lamp may be reciprocally incorporated with rear position lamp.
- A6.6** It shall be possible to switch on or off the front fog lamp/(s), independently of the main-beam headlamp or dipped-beam headlamp.
- A6.7** The rear fog lamp/(s) shall not be lit, unless one or more of the following lamps are lit:

Main-beam head lamp
Dipped-beam head lamp
Front fog lamp.

If there is a front fog lamp, it shall be possible to switch the rear fog lamp off independently of the front fog lamp.

Closed circuit telltale is optional for the front fog lamp. If used, it shall be a green non-flashing indicator light.

Closed circuit telltale is mandatory for the rear fog lamp. It shall be non-flashing amber indicator light.

Annex : B

(See Introduction)

COMMITTEE COMPOSITION
Automotive Industry Standards Committee**Chairman**

Shri. B. Bhanot
Director
The Automotive Research Association of India,
Pune.

Members**Representing**

Shri. Alok Rawat	Ministry of Road Transport & Highways, New Delhi.
Shri. V.C. Mathur	Department of Heavy Industry, Ministry of Industries & Public Enterprises, New Delhi.
Shri. G. S. Kashyab Shri. M.K. Bhat (Alternate)	Office of the Development Commissioner Small Scale Industries, Ministry of Industry, New Delhi.
Shri. A. R. Gulati	Bureau of Indian Standards.
Shri. R. C. Sethi Shri. N. Karupiah (Alternate)	Vehicle Research & Development Establishment, Ahmednagar.
Shri. D.G. Shirke Shri. P. C. Barjatia (Alternate)	Central Institute of Road Transport, Pune.
Shri. R.M. Srivastava	Society of Indian Automobile Manufacturers
Shri. T. M. Balaraman	Society of Indian Automobile Manufacturers.
Shri. I. V. Rao	Society of Indian Automobile Manufacturers
Shri. Z. A. Mujawar (Alternate)	Society of Indian Automobile Manufacturers.
Shri. Vivek Adyanthaya (Alternate)	Society of Indian Automobile Manufacturers
Shri. U. K. Kini (Alternate)	Society of Indian Automobile Manufacturers.
Shri. T. C. Gopalan	Tractor Manufacturers Association, New Delhi.
Shri. Vishnu Mathur	Automotive Components Manufacturers Association.
Shri. K.N.D. Nambudiripad	Automotive Components Manufacturers Association

Member Secretary**Mrs. Rashmi Urdhwareshe**

Sr. Assistant Director,

The Automotive Research Association of India, Pune