

AMENDMENT NO. 1
TO
AIS – 073 (Part 1)
Automotive Vehicles – Wheel Rims for Two and Three Wheeled Vehicles -
Light Alloy Wheel Rims –Methods of
Test and Requirements

1.0 Page No. III, Introduction:

Substitute “AIS - 037 : Procedure for Type Approval and Establishing Conformity of Production for Safety Critical Components”

For “IS: 10694 (Part 5): 1987 General requirements for rims for Automotive Vehicles – Moped, motorcycle and motorcycle derivative rims.

2.0 Page No. 1/15, cl. 2.2:

Substitute “ AIS - 037 : Procedure for Type Approval and Establishing Conformity of Production for Safety Critical Components ”

For “ IS:10694 (Part 5)-1987 : General Requirements for Rims for Automotive Vehicles - Part 5 - Moped, Motor cycle and Motor cycle Derivative Rims.”

3.0 Page No. 1/15, cl. 4.0:

Substitute following text for existing text of entire clause 4.0

“ 4.0 MARKING

4.1 Marking shall be as per AIS 037 as and when AIS 037 is mandated for this standard.”

---- Contd. 2

4.0 Page No. 8/15, Annex B, cl. B 3.0, Test Procedure

Substitute following text for the existing text:

“..... the maximum design load of the wheel rim (see A 2.1),.....”

for

“.....that marked on the wheel,.....”

PRINTED BY
THE AUTOMOTIVE RESEARCH ASSOCIATION OF INDIA
P.B. NO. 832, PUNE 411 004
ON BEHALF OF
AUTOMOTIVE INDUSTRY STANDARDS COMMITTEE
UNDER
CENTRAL MOTOR VEHICLE RULES - TECHNICAL STANDING COMMITTEE
SET-UP BY
MINISTRY OF SHIPPING, ROAD TRANSPORT & HIGHWAYS
(DEPARTMENT OF ROAD TRANSPORT & HIGHWAYS)
GOVERNMENT OF INDIA

April 2007

AUTOMOTIVE INDUSTRY STANDARD

**Automotive Vehicles – Wheel Rims for
Two and Three Wheeled Vehicles -
Light Alloy Wheel Rims –Method of
Test and Requirements**

PRINTED BY
THE AUTOMOTIVE RESEARCH ASSOCIATION OF INDIA
P.B. NO. 832, PUNE 411 004

ON BEHALF OF
AUTOMOTIVE INDUSTRY STANDARDS COMMITTEE

UNDER
CENTRAL MOTOR VEHICLE RULES - TECHNICAL STANDING COMMITTEE

SET-UP BY
MINISTRY OF SHIPPING, ROAD TRANSPORT & HIGHWAYS
(DEPARTMENT OF ROAD TRANSPORT & HIGHWAYS)
GOVERNMENT OF INDIA

December 2005

Status Chart of the Standard to be used by the purchaser
for updating the record

Sr. No.	Corr- igenda	Amend- ment	Revision	Date	Remark	Misc.

General Remarks:

INTRODUCTION

The Government of India felt the need for a permanent agency to expedite the publication of standards and development of test facilities in parallel when the work on the preparation of the standards is going on, as the development of improved safety critical parts can be undertaken only after the publication of the standard and commissioning of test facilities. To this end, Ministry of Surface Transport (MOST) has constituted a permanent Automotive Industry Standard Committee (AISC) vide order No. RT-11028/11/97-MVL dated September 15, 1997. The standards prepared by AISC will be approved by the permanent CMVR Technical Standing Committee (CTSC). After approval, the Automotive Research Association of India, (ARAI), Pune, being the secretariat of the AIS Committee, has published this standard. For better dissemination of this information ARAI may publish this document on their web site.

In recent times light alloy wheels are being widely used for motorcycles in order to reduce the overall weight in the interest of fuel economy. Considering the importance of the wheel as a critical part influencing the driving safety, this standard has been prepared.

Considerable assistance has been taken from following National and International standards.

- | | |
|--------------------------|----------------------------------------------------------------------------------------------------------------|
| IS: 10694 (Part 1): 1993 | Automotive Vehicles - Rims - General requirements Part 1 - Nomenclature, designation, marking and measurement. |
| IS: 10694 (Part 5): 1987 | General requirements for rims for Automotive Vehicles – Moped, motorcycle and motorcycle derivative rims. |
| JASO T 203: 1985 | Light alloy wheels for motorcycles. |

The Automotive Industry Standards Committee responsible for preparation of this standard is given in Annex -G

Automotive Vehicles –Wheel Rims for Two and Three Wheeled Vehicles - Light Alloy Wheel rims – Method of Test and Requirements

1.0 SCOPE

- 1.1 This Standard prescribes the general and performance requirements of light alloy wheel rim intended for use on two and three wheeled motor vehicles with or without side car.

2.0 REFERENCES

- 2.1 IS:10694 (Part 1)-1993 : Automotive Vehicles - Rims - General Requirements Part 1 - Nomenclature, Designation, Marking and Measurement.
- 2.2 IS:10694 (Part 5)-1987 : General Requirements for Rims for Automotive Vehicles - Part 5 - Moped, Motor cycle and Motor cycle Derivative Rims.

3.0 DEFINITIONS AND NOMENCLATURE

- 3.1 Definitions and Nomenclature shall be as per IS 10694 (Part 1)- 1993

3.2 Typical types of Light Alloy Wheel rim

- 3.2.1 **“Unit construction light alloy wheels”** wheels of which the rim and spokes or the disc, are manufactured as single unit. (see Fig.1)
- 3.2.2 **“Composite construction light alloy wheels”** wheels of which the rim is made of light alloy and the spokes or disc of light alloy are steel, which are then assembled. (see Fig.1)

4.0 MARKING

- 4.1 Wheel Rims shall be durably and legibly marked with the following:
- a) Size designation shall be as per IS 10649 (Part 5)- 1987
 - b) Name or trade mark of the Wheel rim manufacturer
 - c) The letter “HD” for rims designed for three wheeled goods carriages.
 - d) Light alloy wheels for tubeless tyres application shall be marked with “TUBELESS or TUBELESS TYRE APPLICATION or SUITABLE FOR TUBELESS TYRES
- 4.2 The marking shall be recessed and without sharp edges and letters shall not be smaller than 3mm and impressed/engraved/die-casted to a depth/embossed in a legible manner.
- 4.3 The marking shall be visible after the tyre is mounted and inflated.

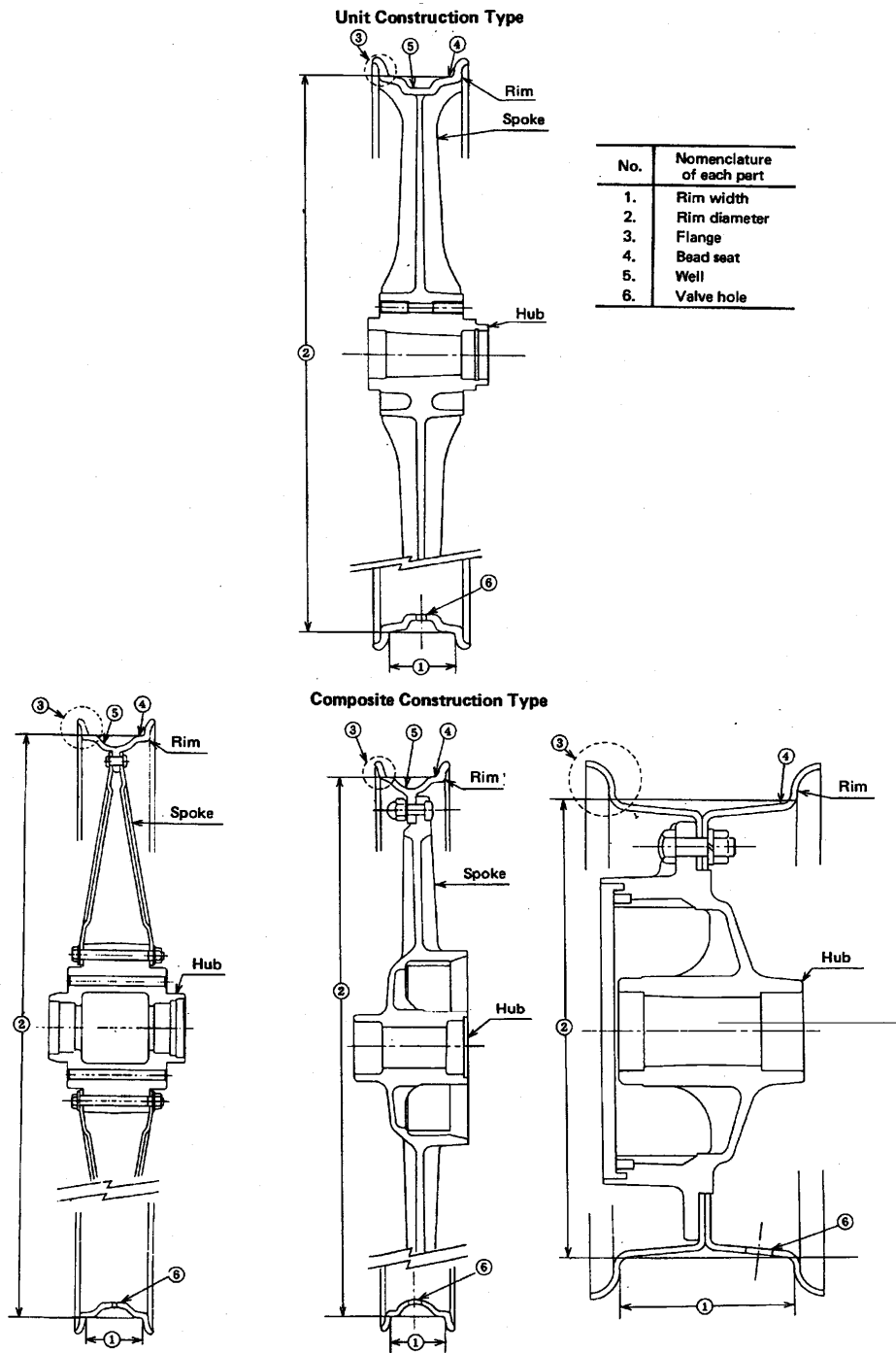

Fig 1 Types of Light Alloy Wheel rims and Nomenclature

5.0 TYPE APPROVAL

- 5.1 The manufacturer should submit the details as specified in Annex F
- 5.2 Number of rims to be provided shall be minimum 4 nos. for tube type tyre application (2 nos with tyre and tube assembly) and 5 nos. for tubeless tyre application or at the discretion of testing agency.
- 5.3 If the type of wheel rim submitted for approval in pursuance of this standard meets the requirements of this standard, approval for that type of wheel rim shall be granted.

6.0 REQUIREMENTS RELATING TO WHEEL RIMS

6.1 General Requirements

- 6.1.1 The rims shall have a smooth contour free from sharp edges, on the tyre and tube-mounting surface.
- 6.1.2 The valve hole shall be clean, free from burrs and shall not have such shapes and surface condition which harm the functions of tyre, tube and valve.
- 6.1.3 The surface of the rim shall be free from any crack, crazing or any other similar structural defect.
- 6.1.4 Light alloy wheels for tubeless tyres shall not have any defects, such as pinholes, which are harmful for air tightness of the rims.

6.2 Rotation Bending Fatigue Test (Dynamic Cornering Fatigue Test)

- 6.2.1 Each type of wheel rim shall undergo rotation bending fatigue test carried out by the procedure described in Annex A to this standard.
- 6.2.2 After being subjected to 10^5 cycles according to the rotation bending fatigue test specified in Annex A, there shall be no evidence of harmful cracks, significant deformation or any abnormal looseness at joints.

6.3 Radial Load Durability Test

- 6.3.1 Each type of wheel rim shall undergo radial load durability test carried out by the procedure described in Annex B to this standard.
- 6.3.2 After being subjected to 5×10^5 cycles of the radial load durability test specified in Annex B, there shall be no evidence of harmful cracks, significant deformation, or any abnormal looseness at joints.

6.4 Radial Impact Resistance Test

- 6.4.1 Each type of wheel rim shall undergo radial impact resistance test carried out by the procedure described in Annex C to this standard.

- 6.4.2 After being subjected to the radial impact resistance test specified in Annex C there shall be no evidence of harmful cracks, significant deformation, abnormal looseness at joints, or any sudden air leakage due to failure of the rim.

NOTE: Sudden air leakage shall be a case where the test pressure drops by more than 50 percent in less than 30 seconds.

6.5 Torsion Moment Test

- 6.5.1 Each type of wheel rim shall undergo torsion moment test carried out by the procedure described in Annex D to this standard.

- 6.5.2 After being subjected to 10^5 cycles of the torsion test as specified in Annex D, there shall be no evidence of harmful cracks, significant deformation or any abnormal looseness at joints.

6.6 Air Leak Test (Tubeless Tyres Wheel Rim)

- 6.6.1 Each type of wheel rim shall undergo air leak test carried out by the procedure described in Annex E to this standard.

- 6.6.2 There shall be no leakage of air as indicated by bubbles through the rim of the wheel after application of the test procedure in accordance with Annex E for a minimum period of 2 minutes.

Note:- *No wheel rim shall be used for more than one test for performance test mentioned at Cl 6.2 to 6.6*

7.0 MODIFICATION AND EXTENTION OF APPROVAL OF WHEEL RIM TYPE.

- 7.1 Every modification of the type of wheel rim shall be notified to testing agency, which has approved the type of wheel rim. The test agency may then either

- 7.1.1 Consider that the modification made are unlikely to have an appreciable adverse effect and that in any case, the wheel rim still complies with the requirement; or

- 7.1.2 Require a further test report from the testing agency responsible for conducting the test.

For considering whether any further verification is required or not, guidelines given in 7.3 (criteria for extension of type approval) may be followed.

- 7.1.3 In case of 7.1.2, check for those parameters which are affected by modifications, only need to be carried out.

- 7.2 In the event of 7.1.1 or in case of 7.1.2 after successful compliance to the requirements, a certificate of compliance shall be validated for the modified version.

- 7.3 Criteria for extension of type approval

- 7.3.1 In case of following changes, testing shall be carried out for establishing compliance of the changed parameters to the requirements specified in this standard:

- 7.3.1.1 Increase in the load carrying capacity
- 7.3.1.2 Any change in the design of the wheel rim
- 7.3.1.3 Any change in the material of the wheel rim
- 7.3.1.4 Any change in the thickness of the wheel rim
- 7.3.1.5 Any change in the inset/outset of the wheel rim

ANNEX A
(See 6.2)

ROTATION BENDING FATIGUE TEST

A 1.0 Test equipment

- A 1.1 The test equipment shall have a driven rotatable device whereby either the wheel rim rotates under the influence of a stationary bending moment or wheel stationary and is subjected to a rotating bending moment.
An example of such equipments is shown in Fig 2A and Fig 2B

A 2.0 Test Conditions

A 2.1 Bending Moment

The bending moment M , in Nm applied, shall be determined by the following equation:

$$M = S_m \times \mu \times W \times r$$

Where

- S_m - is a coefficient equal to 0.7;
 μ - is the friction coefficient between tyre and road, equal to 0.7;
 W - is the maximum design load of the wheel rim, in Newtons (N) and
 r - is maximum static loaded radius for which wheel rim is designed ,
in metres (m).

A 2.2 Loading arm length

The length of the loading arm shall be such that the calculated moment M , is obtained by applying a mass equal to W as defined in clause A 2.1

- A 2.3 The tolerance for M -Moment fluctuation during the test shall be ± 2.5 percent.

A 3.0 Test Procedure

The wheel shall be rotated along with the test equipment or wheel rim shall be held stationary and subjected to rotating bending moment by applying a bending movement M , determined in accordance with A 2.1 , after the rim flange of the light alloy test wheel has been fixed. A loading arm of the length specified in A 2.2, of sufficient rigidity shall be attached to the wheel by the same method as the wheel is normally attached to a vehicle.

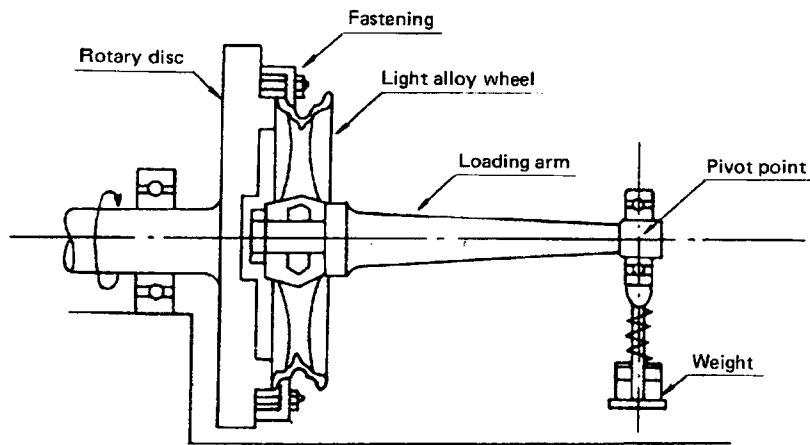

2A

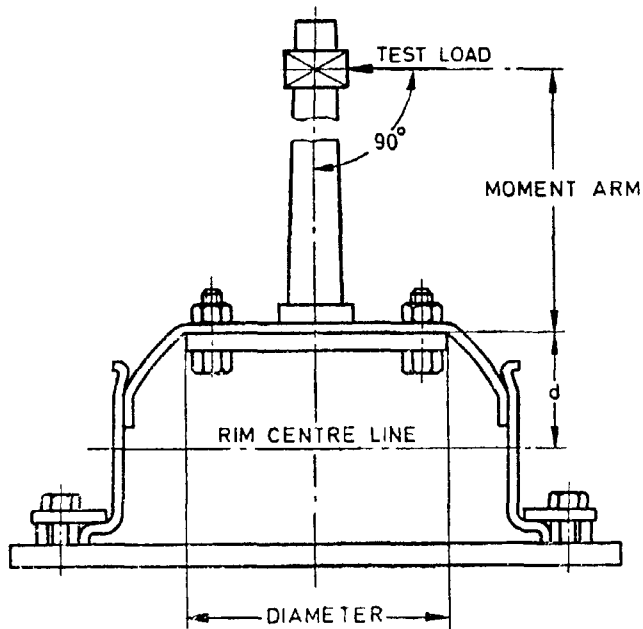

2B

Fig 2 Model Equipment for Rotational Bending Fatigue Test

ANNEX B

(See 6.3)

RADIAL LOAD DURABILITY TEST**B 1.0 Test Equipment**

B 1.1 The test equipment shall meet the following requirements:

- a) The test equipment shall have a drum with a smooth surface which is wider than the overall width of the tyre used in the test. The diameter of the drum shall be greater than or equal to 400 mm.
- b) The drum specified in (a) shall rotate at a constant velocity.
- c) The test equipment shall permit a radial load to be applied to the wheel. The equipment shall be such that the wheel is maintained in contact with the drum under constant pressure.

Figure 3 shows the example of such equipment.

B 2.0 Testing conditions**B 2.1 Static Radial Load**

The radial load Q , in Newtons to be applied shall be determined by the equation:

$$Q = S_r \cdot W$$

Where

- S_r is a coefficient equal to 2.25 and
- W is as defined in Clause A 2.1

B 2.2 Tyre Air Pressure

The air pressure before the test, in kPa shall be at least that corresponding to the design maximum load of the tyre to be used in the test.

B 2.3 Tolerance for Load Fluctuation

The tolerance for load fluctuation during the test shall be ± 5 percent.

B 2.4 Tyre Failure

In case of tyre failure, the test shall be continued after replacing the tyre

B 3.0 Test Procedure

The wheel rim, fitted with a tyre the rated load of which is at least equal to that marked on the wheel, shall be mounted on the test equipment according to the method used for attaching the wheel to the vehicle. The drum shall then be rotated while the radial load Q , determined in accordance with Clause B 2.1 is applied.

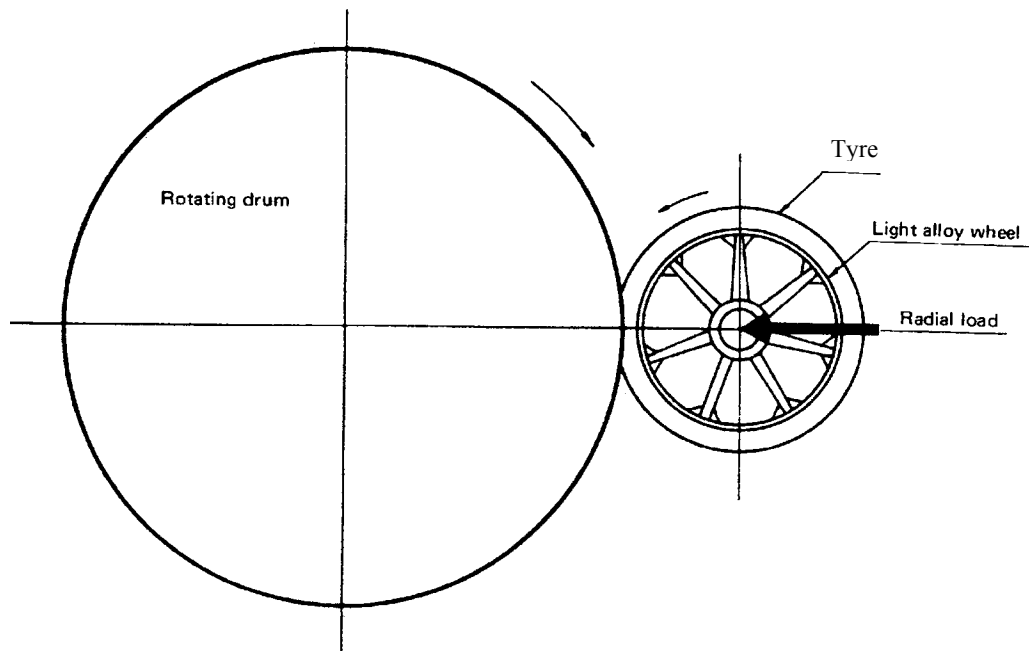

Fig 3 Model Equipment for Radial Load Durability Test

ANNEX C
(See 6.4)

RADIAL IMPACT RESISTANCE TEST

C 1.0 Test Equipment

C 1.1 The equipment shall have the following conditions:

- 1) The equipment shall be so constructed that the light alloy wheel with a tyre attached can be mounted on a stand having sufficient stiffness and strength, and a striker weight made of steel can be dropped freely and strike the wheel. An example of such equipment is shown in Fig.4
- 2) The combined spring constant of two coil spring shall be 2942 ± 98 N/cm (300 ± 10 kgf/cm), and 100 mm stroke shall be provided for the auxiliary striker weight before it comes into contact with the main weight.

C 2.0 Test Conditions

C 2.1 Impact load

By using the test equipment indicated in C 1.1, the striker weight shall be dropped to apply the impact load. The total mass of the striker weight shall be pursuant to the following equation:

$$m_1 + m_2 = K \frac{W}{g}$$

Where,

$m_1 + m_2$: Total mass of striker weight (kg)

m_1 : The mass of main striker weight $\pm 2\%$ (kg)

m_2 : The mass of auxiliary striker weight (including the mass of the springs)
 40 ± 2 kg

W: Pursuant to the provisions of A 2.1

K: Coefficient- 1.5

g: Gravitation acceleration 9.8 (m/s^2)

C 2.2 Tyre Inflation Pressure:

The tyre inflation pressure, p, in kPa shall be determined by the following equation:

$$p = (\text{the air pressure corresponding to the design maximum load of the tyres to be used in the test} \times 1.15) \pm 10$$

Note: *Test Agency will decide suitable tyres for this test*

C 3.0 Test Procedures

C 3.1 The light alloy wheel to be tested, being attached with the tyre specified in C 2.0, shall be mounted on the stand according to the attachment method to a vehicle; the relative positions shall be so determined that the centers of the rim and the striker weight may be aligned (refer to fig.4); and the striker weight shall be dropped from the height of 150 mm.

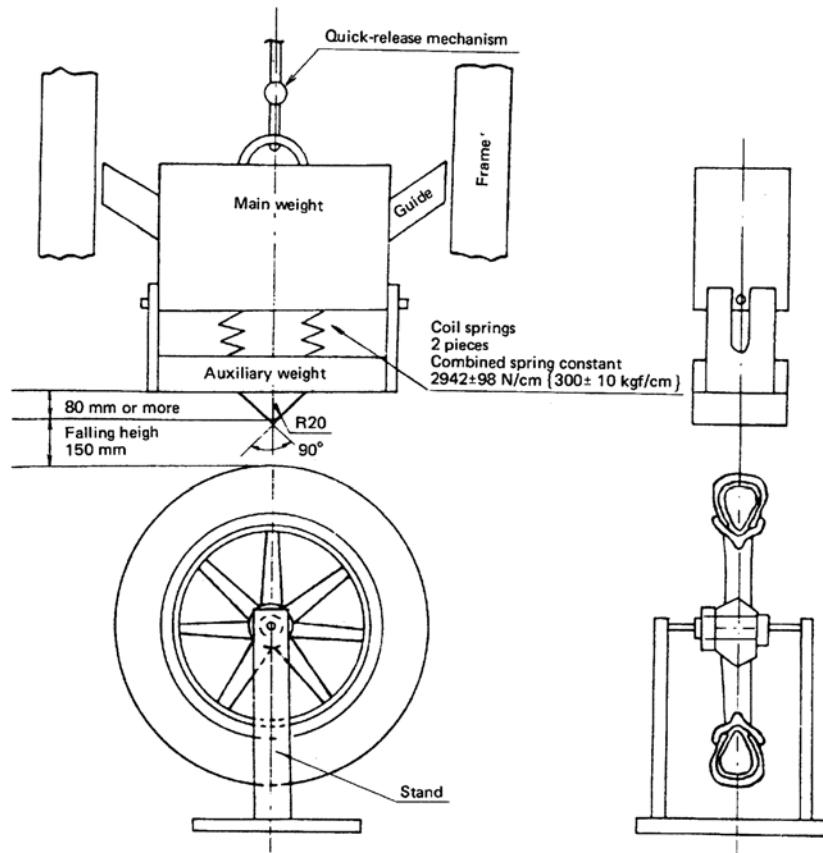

Fig 4 Model Equipment for Radial Impact Resistance Test

ANNEX D
(See 6.5)

TORSION MOMENT TEST

D 1.0 Test Equipment

- D 1.1 The test equipment shall permit a torsional moment to be applied between the hub and the rim.
Figure 5 shows the example of such equipment.

D 2.0 Test Conditions

- D 2.1 The torsional moment, T in Nm shall be applied and shall be determined by the equation:

$$T = \pm W \cdot r$$

Where W and r are as defined in Clause A 2.1

D 3.0 Test Procedure

- D 3.1 The flange of the wheel rim shall be fixed to the support and the torsional moment determined according to D 2.0 shall be applied repeatedly through the contact face of the hub. The length of the loading arm shall be equal to the radius of the smallest tyre suitable for the wheel.

It is also permissible to fix the wheel to the support through the contact face of the hub and apply the torsional moment to the wheel rim by means of an annular ring rigidly attached to the rim.

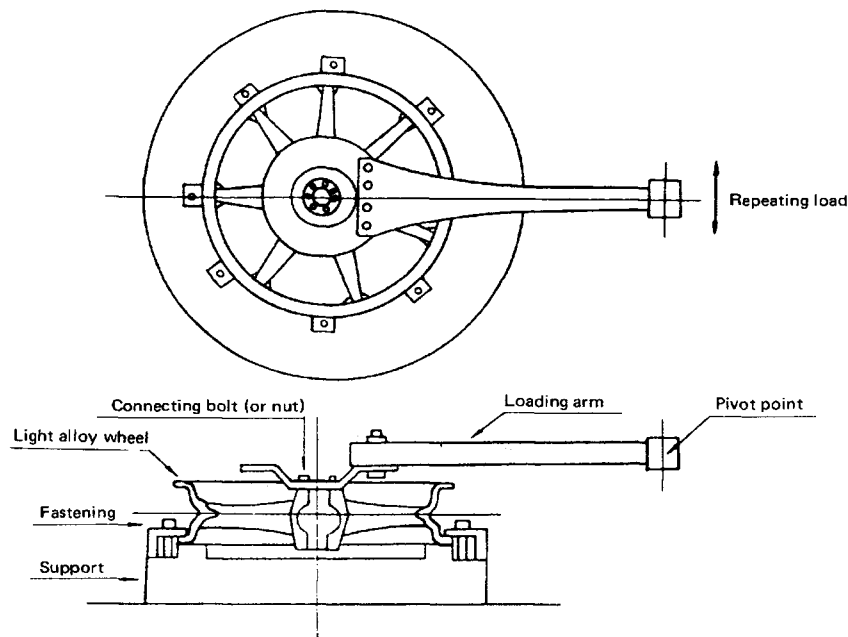
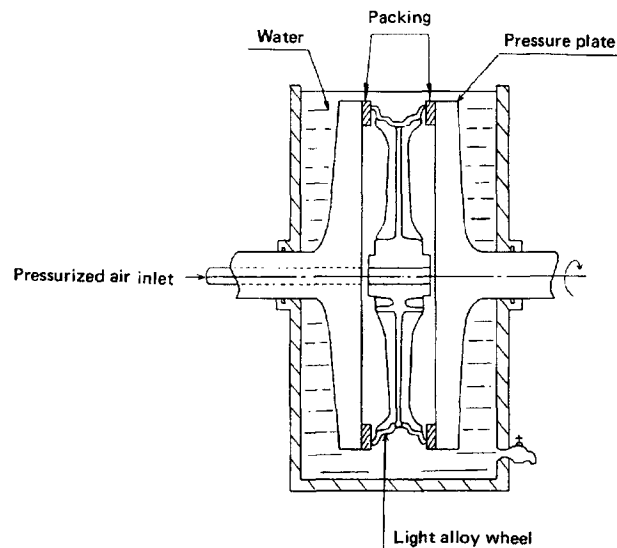

Fig 5 Model Equipment for Torsion Moment Test

ANNEX E
(See 6.6)**AIR LEAK TEST**

- E 1.0** This is applicable only to wheels designed and marked for use with tubeless tyres. Figure 6 shows the example of such equipment.
- E 2.0 Test Equipment**
Air leak testing equipment
- E 3.0 Test Conditions**
The air pressure to be applied according to Clause E 4.0 shall be 300 kPa or more.
- E 4.0 Test Procedure**
- E 4.1 Both sides of the flange shall be tightly closed by the pressure plates and the pressurised air as indicated in E 3.0 shall be supplied to the inside of the wheel in order to confirm the air tightness of the rim.
- E 4.2 Alternatively for rims of divided construction where sealing rings are used, the rim may be fitted with a tyre, the tyre inflated and the whole assembly immersed in water.

**Fig 6 Model Equipment for Air Leak Test**

ANNEX F
(See 5.0)

Technical Information to be submitted by Supplier

1.	Name of Supplier:	
2.	Address of Supplier	
3.	Telephone No	
4.	FAX. No.	
5.	E mail address	
6.	Contact person	
7.	Wheel rim manufacturer name (In case different for supplier)	
8.	Address of wheel rim manufacturer (In case different for supplier)	
9.	The trade/brand name or mark	
10.	Wheel Rim size designation	
11.	Type of wheel rim (To be specified)	
12.	Location Rear/front/both	
13.	Whether the rim is intended to be used with tube or tubeless tyre	
14.	Maximum design load of wheel rim	
15.	Maximum static loaded radius (r) for which wheel rim is designed, in meters (m)	
16.	Engineering Drawing of wheel rims giving details of profile, relevant dimensions, tightening torque for wheel rims, Inset/outset, markings etc., in triplicate	

ANNEX G
(See Introduction)
COMMITTEE COMPOSITION *
Automotive Industry Standards Committee

Chairman	
Shri B. Bhanot	Director The Automotive Research Association of India, Pune
Members	Representing
Shri Alok Rawat	Ministry of Shipping, Road Transport & Highways, New Delhi
Shri Sushil Kumar	Department of Heavy Industry, Ministry of Heavy Industries & Public Enterprises, New Delhi
Shri Chandan Saha	Office of the Development Commissioner, Small Scale Industries, Ministry of Small Scale Industries, New Delhi
Shri S. Dasgupta Shri S. K. Bhatia (Alternate)	Bureau of Indian Standards, New Delhi
Shri A. S. Lakra Shri D. P. Saste (Alternate)	Central Institute of Road Transport, Pune
Director	Indian Institute of Petroleum, Dehra Dun
Dr. C. L. Dhamejani Dr. N. Karuppaiah (Alternate)	Vehicles Research & Development Establishment, Ahmednagar
Shri Dilip Chenoy	Society of Indian Automobile Manufacturers
Shri T.C. Gopalan Shri Ramakant Garg (Alternate)	Tractor Manufacturers Association, New Delhi
Shri K.N.D. Nambudiripad	Automotive Components Manufacturers Association New Delhi
Shri G. P. Banerji	Automotive Components Manufacturers Association New Delhi

Member Secretary
Mrs. Rashmi Urdhwaresh
Deputy Director
The Automotive Research Association of India, Pune

* At the time of approval of this Automotive Industry Standard (AIS)